

# Fresh Intellivent ICE

Cat. Part Number 197406

- Unique air quality sensor
- Intelligent and self-adjusting humidity control
- Superior pressure performance
- Fine tuning with touch panel or app connectivity
- Light sensor for timer start



**Intellivent ICE is a bathroom fan loaded with ingenious sensors to give you a healthy and comfortable environment in the bathroom, toilet and laundry room.**

## Functions

Intelligent Humidstat, Light Sensor, Odour Sensor, Delay Timer, Run on Timer, Constant Volume, Switch Live

## Tecnical data

Installation type, wall, ceiling etc	Horizontal , Vertical
Maximum pressure (Pa)	57
Free to air Max (m3/h)	140
Sound pressure level 3m dB(A)	19
Max watt(W)	5
Supply Voltage (12V-400V)	100V AC, 110V AC, 230V AC
Electrical Supply Phase	1-Phase
Insulation Class	II
Type of motor	EC
Wireless Control Option	Bluetooth LE
Protection ( IP )	IP 44
Duct size nominal Ø (mm)	100, 120, 125
Unpackaged Product Width (mm)	185
Unpackaged Product Height (mm)	160
Unpackaged Product Depth (mm)	67
Material	Plastic
Plastic Material detail	ABS
Etim Code	EC001141

## Measure sketch/CAD

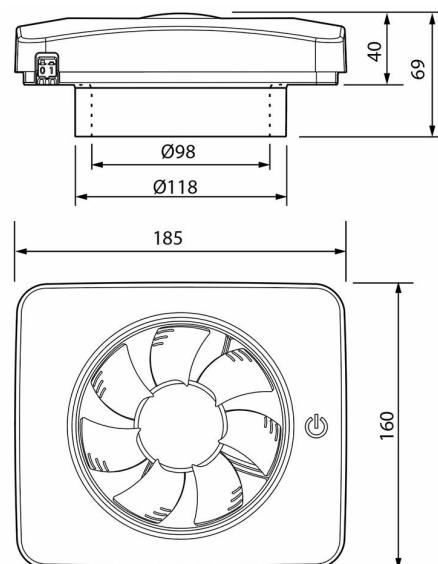

## Description

### Intelligent ventilation

With a unique odour sensor, unrivalled extraction capacity, and advanced moisture control, Intellivent ICE is optimised to produce a fresh and comfortable bathroom climate.

### Air quality sensor

Intellivent ICE is the only bathroom fan in the world equipped with an air quality sensor that is able to detect strong odours. When the sensor detects a strong odour, the fan speed increases and quickly neutralises the odour to ensure the air always feels fresh.

### Superior pressure performance

The fan is completely unrivalled when it comes to extraction capacity, which means it can cope with long ducts and bends without compromising ventilation.

### Self-adjusting humidity control

Intellivent ICE has a fully automatic humidity control, which means it activates automatically when it detects an elevated moisture level.

When the moisture in the room increases, the fan increases its airflow to ensure that the climate in the bathroom remains comfortable.

### Extremely quiet

Although Intellivent ICE is equipped with a new, significantly more powerful motor than all its predecessors, the fan is almost silent.

### Autonomous

Another one of Intellivent ICE smart features is its light sensor. The fan recognises when you enter a room and activates.

This means that, together with the aeration program that starts after the fan has been idle for 26 hours, the fan is fully autonomous.

The fan is therefore ideal for any areas subjected to moisture and odours. Perfect for bathrooms, basements, or summerhouses.

### Touchscreen

An intuitive and unique touchscreen activates when you touch the On/Off button. The fan's most important functions can be controlled from here.

When you are finished, the screen dims and becomes virtually invisible again. And the fan can be restored to the default factory settings through the simple push of a button.

### Fine-tuning via the App

With our Fresh Ventilation Bluetooth app, you can customise multiple functions according to your particular conditions.

This is highly practical if the fan is mounted in the ceiling and the touchscreen is hard to reach.

### Simple installation

Thanks to its practical design and cable quick-connectors, Intellivent ICE is easy to both mount and install.

When you want to clean the fan, the impellor can be easily removed with one hand. The fan is certified for both ceiling and wall installation.

### Developed, designed and manufactured in Sweden

Intellivent ICE is the bathroom fan of the future, and it is the product of expert craftsmanship, past experience, accuracy and precision. Swedish-made quality with technology and design in perfect harmony.

### Design front

The design front is easily placed on the fan with magnetic attachment.

## Accessories



**Chuck D32-210**  
Cat 804046



**Chuck extender D32-210**  
Cat 804048



**Hole saw D127**  
Cat 804044



**External grille #150 white**  
Cat 181701



**Wall pipe D118/122x150**  
Cat 185150



**Wall pipe D98/102x100**  
Cat 188010



**Through wall kit Intellivent YVG D125**  
Cat 197245



**Adapter 10 external D98/102x60**  
Cat 661062



**Backdraught protection D98**  
Cat 669801



**Backdraught protection D125**  
Cat 669812



**Front Intellivent Sky vit**  
Cat 197418



**Intellivent cover plate, white**  
Cat 197430



**Through wall kit Intellivent YVG D100**  
Cat 197243