

# HELTY®

Pure air for your home



Made in Italy



# HRV systems and indoor comfort

*Home range*

March 2026

# Healthy breathing in every room

A healthy lifestyle is inextricably linked to the air we breathe. Air is the first and most important nutrient for all forms of life. On average, a person breathes more than 12,000 litres of air a day.

*Choosing to breathe air that is healthy because it is constantly exchanged and purified is essential*

Helty is committed to improving air quality everywhere you live and work. Our mission is **to bring healthy breathing everywhere – in homes, offices, classrooms and public places.**

We do this by offering a range of innovative **heat recovery ventilation** solutions for system designers and installers systems. Our decentralised dual-flow systems are stylish, easy to install, energy-efficient and have proven pollutant-reducing effectiveness.

To make the indoor places where we spend most of our time healthier, more pleasant and comfortable.





# Table of Contents

<b>Who is Helty</b>	<b>6</b>
The Alpac Group	7
Case History	8
CasaClima Quality Seal	10
BioSafe Validation	11
ErP Directive Compliance	12
Focus: Indoor Air Quality	14
<b>How Helty Flow Works</b>	<b>16</b>
<b>The Flow Range</b>	<b>18</b>
Flow-R Line	20
Wall-mounted HRV	22
Wall recessed HRV	42
FlowMANHATTAN HRV for Exterior Cladding	68
IAQ Indoor Air Quality Sensors	76
Control Panel	78
Helty Home App	80
Filters and Spare Parts	81
<b>Useful Resources</b>	<b>82</b>
ESG: well-being and sustainable development	82

News

News

© Helty

Helty adopts a continuous product improvement policy and therefore reserves the right to change the design, specifications and data in this catalogue without prior notice. The images are not contractually binding.

# Who is Helty

*Decentralised HRV to put health and energy efficiency at the core*

Helty is the Alpac Group company specialising in **decentralised solutions for heat recovery ventilation and indoor comfort**. We work alongside heating engineers, system designers and installers, energy consultants, building health experts and construction companies to **spread the culture of healthy air in living and working environments**.

We deal exclusively in **decentralised heat recovery ventilation (HRV) systems** with high air filtration and heat recovery efficiency. This **technology is indispensable in energy-efficient buildings** and necessary for energy upgrades to **prevent building illnesses, increase the value of the building and safeguard people's comfort and health**.

The **HRV solutions are developed and manufactured by Helty entirely in Italy**. They are exclusively of the **continuous dual-flow** type for exchanging the air in rooms constantly in a balanced manner and with variable flow rates. The air is purified by removing pollutants, pollen and particulates.

## Certifications and partnerships

Energy efficiency is improved, in addition to comfort, in homes that implement Helty ventilation. The heat recovery units in Helty HRV units ensure heat recovery efficiency of up to 91% and are tested in accordance with EN 13141-8 by an external laboratory accredited by TÜV SÜD. The performance of Helty ventilation systems is certified by the **CasaClima HRV Quality Seal and validated by BioSafe**. Helty is a member of **AiCARR** and **CTI** (Comitato Termotecnico Italiano).





# ALPAC®

## The Alpac Group: better buildings for a better world

For over 40 years, the Alpac Group has been **supporting construction professionals in the creation of energy-efficient, more sustainable and thermally and acoustically comfortable buildings** by designing and manufacturing window management and insulation systems, as well as decentralised technologies for indoor air exchange and filtration.

In the world of design and construction, the Alpac Group is the by-word for **quality, research and development**, with a focus on **efficiency and health**.

In addition to **Helty** and **Alpac**, leading players in window insulation systems for new builds and renovation projects, the industrial group now includes **Incovar**, based in Puglia, Italy, specialising in the production of roller shutter boxes and monoblock systems, **Alpac Tecnologica Europea**, operating in Spain with solutions for window opening insulation and **Alpac France**, a commercial subsidiary operating in the French market. The technologies offered by the companies of the Group are **used in many construction**

**projects across Italy and Europe, ranging from minor retrofits to large-scale building sites.**

The Alpac Group received the **Best Managed Companies Award** for the period 2019–2025 promoted by Deloitte to support and recognise Italian business excellence for its ability to support organisational growth through initiatives focused on **continuous innovation, personal development, environmental commitment** and process digitalisation.



# Case history

## 126 Martini

Roma, CAM Costruzioni  
Renovation of a building with  
new designer residences in  
the heart of the EUR district,  
in Rome.



## Former Collegio Nardari

Treviso, Archi-Plan Studio,  
renovation and energy  
upgrades of an early 20th  
century building in the city  
centre

## Balduina 142

Roma, RDP Costruzioni,  
Studio Marzullo, Socip,  
Class A building





*Mezzocammino  
residential building*

Rome, Studio Transit,  
Atlantico Costruzioni



*Progetto Sinfonia*

Bolzano

# CasaClima Quality Seal

Quality assurance for  
customers and designers

The Helty FlowULTRA and Flow40/120 ventilation systems have been awarded the Product Quality label by the **Bolzano CasaClima Agency**.

The CasaClima product Quality Seal provides **transparent evaluation and informs buyers and designers about the best solutions on the market**. The seal is a reliable and recognised certification in the construction sector, granted only to products that meet the highest quality standards.

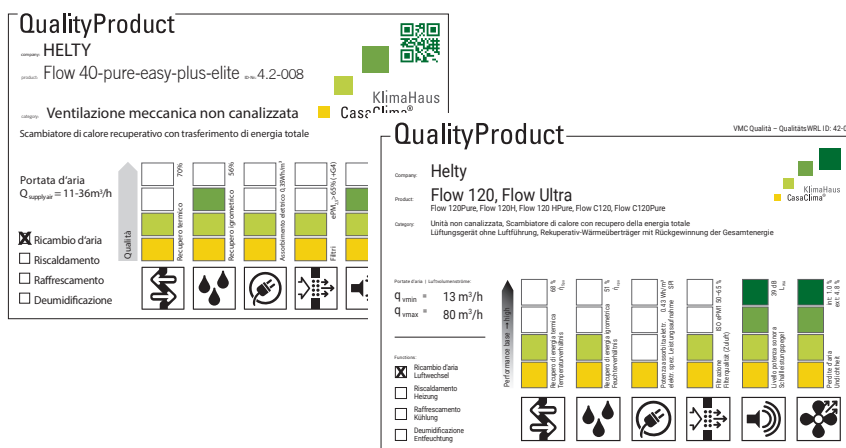

More specifically, the **CasaClima HRV Quality Seal** takes into account the five main characteristics of a ventilation system referred to in **UNI EN 13141-8 standards** – heat and moisture recovery, electricity consumption, filtration, acoustics and air leakage – and assigns a performance level value to each one.

The product description, values and any additional device features of the unit are illustrated on a summary label to guide users in choosing the best solution for their needs.

# BioSafe Validation

For protecting health  
and air quality

Helty Flow systems have passed the test protocol, fully complying with the **BioSafe® Environmental Health Certification Protocol** for verifying, planning and managing the indoor air quality index in energy-efficient buildings.

Through a **patented certification protocol**, Biosafe has subjected Helty Flow HRV solutions to in-depth analysis according to the strictest emission quality standards. The examination was carried out on two levels by **sampling and testing air samples** with CG-MS (pursuant to UNI EN ISO 16000-9 and UNI ISO 16000-6) and through **environmental surveys** (pursuant to ISO 16000-4 and UNI EN ISO 16017-2 with reference to UNI EN 14412 requirements), with product field testing followed by on-site analysis of the effects on indoor air quality.

The **Biosafe® Validation Seal** is an additional guarantee of **living comfort** in terms of design and indoor comfort once the installation is complete. Biosafe® certification aligns with the health and safety requirements set by the **CAM**, which are relevant for public procurement contracts.

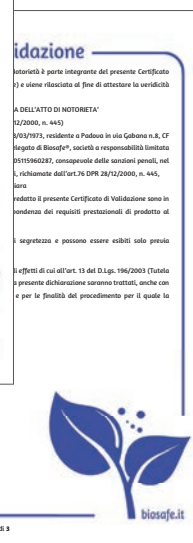
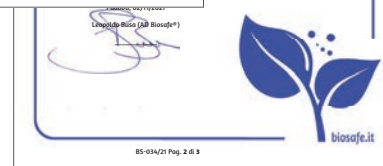

# ErP Directive Compliance

## Eco-design and energy labelling

All Hely mechanical ventilation systems fully comply with the energy requirements of the European ErP (Energy Related Products) directive, created to improve the efficiency of devices marketed in the European Union while protecting the environment.

The EU directive has two areas of impact on ventilation systems:

// **Ecodesign Directive 2009/125/EC** imposes minimum energy performance values to be achieved by household appliances.

The Ecodesign regulation on ventilation systems (No. 1253/2014) sets out the energy performance requirements for products launched from 1 January 2016. These requirements were consolidated on 1 January 2018.

// **Regolamento (UE) 2017/1369 Energy Labelling**

imposes the energy class assessment of the device (A to G) to promote the purchase of more efficient products.

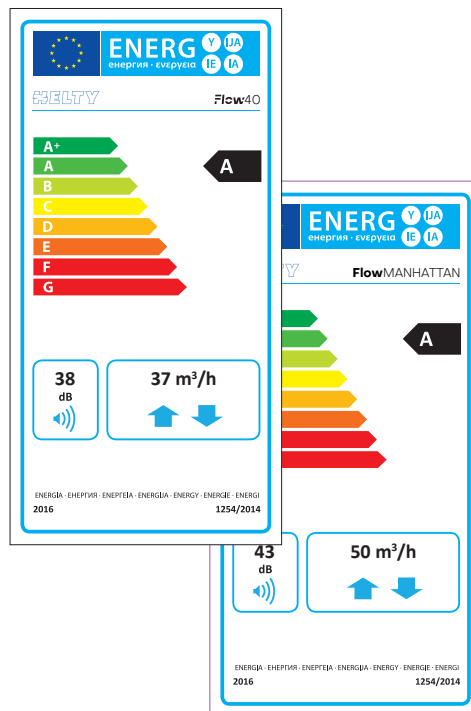



# Indoor air quality

## What do we breathe?

Every day **we spend around 90% of our time indoors**, mainly at home and in the workplace.

Confined environments have a limited amount of air, which we consume with every breath.

A person takes an average of **22,000 breaths per day**, passing about **12,000 litres of air** through their lungs.



## Indoor air is up to 20 times more polluted

It is important for our health to breathe clean air, rich in oxygen and free of the pollutants that inevitably accumulate and concentrate in closed, unventilated rooms.

As confirmed by multiple studies, **indoor air can be 5 to 20 times more polluted than outdoor air**. Without adequate ventilation, indoor air tends to deteriorate, becoming saturated with harmful substances that can be very dangerous to health.

Harmful elements can include **ultra-fine dust, fumes, combustion gases, formaldehyde, volatile organic compounds** released by chemical cleaners, glues and furnishing materials. Furthermore, there are pollutants of biological origin – microorganisms, such as **allergens, moulds, bacteria**, aerosol-borne viruses – and of physical origin, such as the dreaded **radon gas**.

## Main pollutants and their impacts on health



### Particulates

causes eye, nose and throat irritation and breathing problems, headaches, fatigue and low concentration. Prolonged contact can lead to heart and respiratory diseases.

### Viruses

viruses can be emitted simply by coughing or breathing and linger in the air in the form of bioaerosols for some time



### Moulds

release health-damaging spores that cause allergies



### Humidity

causes condensation, mould and dust mite proliferation



### VOC

airborne substances, including formaldehyde, which may create respiratory tract irritation or central nervous system problems

### Radon

is an odourless and colourless radioactive gas of natural origin released from the soil. It qualifies as the second leading cause of risk for lung cancer



### CO<sub>2</sub>

in excessive concentrations, such as when feeling the sensation of stale air, causes headaches and difficulty in concentration



# How does it work?

## Helty Flow: continuous air exchange and filtration

All Helty ventilation units are **decentralised dual-flow HRVs** with cross-flow countercurrent. **The stale air, laden with humidity and CO<sub>2</sub>, is aspirated in from the indoor environment** and fed into the heat exchanger, where – without any contact between the two flows – it surrenders its heat to the incoming airflow, which is brought in from outside at the same time.

**The oxygen-rich fresh air is pre-heated and purified** by a high-performance filter that blocks smog, particulate matter and pollen. This technology allows a **constant and balanced air exchange** in closed rooms for **superior performance** in terms of energy efficiency, air purification and indoor comfort.

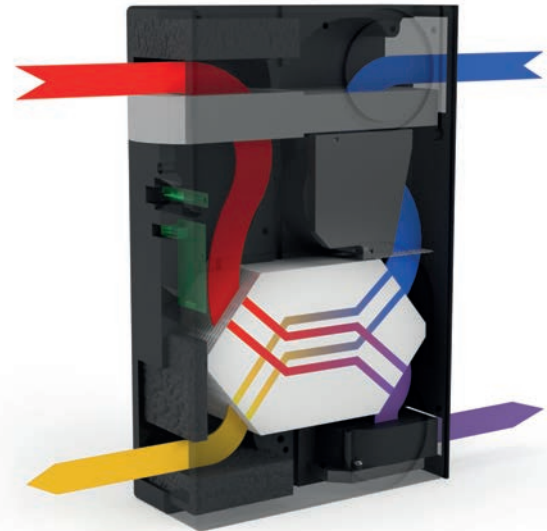

- red arrow: exhaust air aspirated from inside
- purple arrow: stale air expelled outside
- blue arrow: external fresh air
- yellow arrow: filtered and pre-heated replenished air



## Healthiness and energy-saving for all climate zones

**Energy efficiency** is ensured by the **heat recovery unit**, available for the first time in two versions – **sensible and enthalpy** – to meet any climate requirements, with heat recovery efficiency of up to 91% (in the enthalpy version).

The **ePM2.5 65% filter** prevents the ingress of dust and pollen, but also of **PM10** and **PM2.5** particulate matter, to protect the healthiness of the air you breathe in your home. Quiet operation and verified **façade noise reduction values contribute to** optimal acoustic comfort.

## Benefits of HRV

- it guarantees ensures fresh, oxygen-rich air
- it counteracts the airborne spread of viruses and bacteria
- it filters particulates and pollen from the external air
- it removes excess humidity while counteracting condensation and mould problems
- it dilutes CO<sub>2</sub> and pollutants dispersed in indoor air
- it decreases allergens and dust mites
- it reduces fumes and odours
- it mitigates radon gas risk

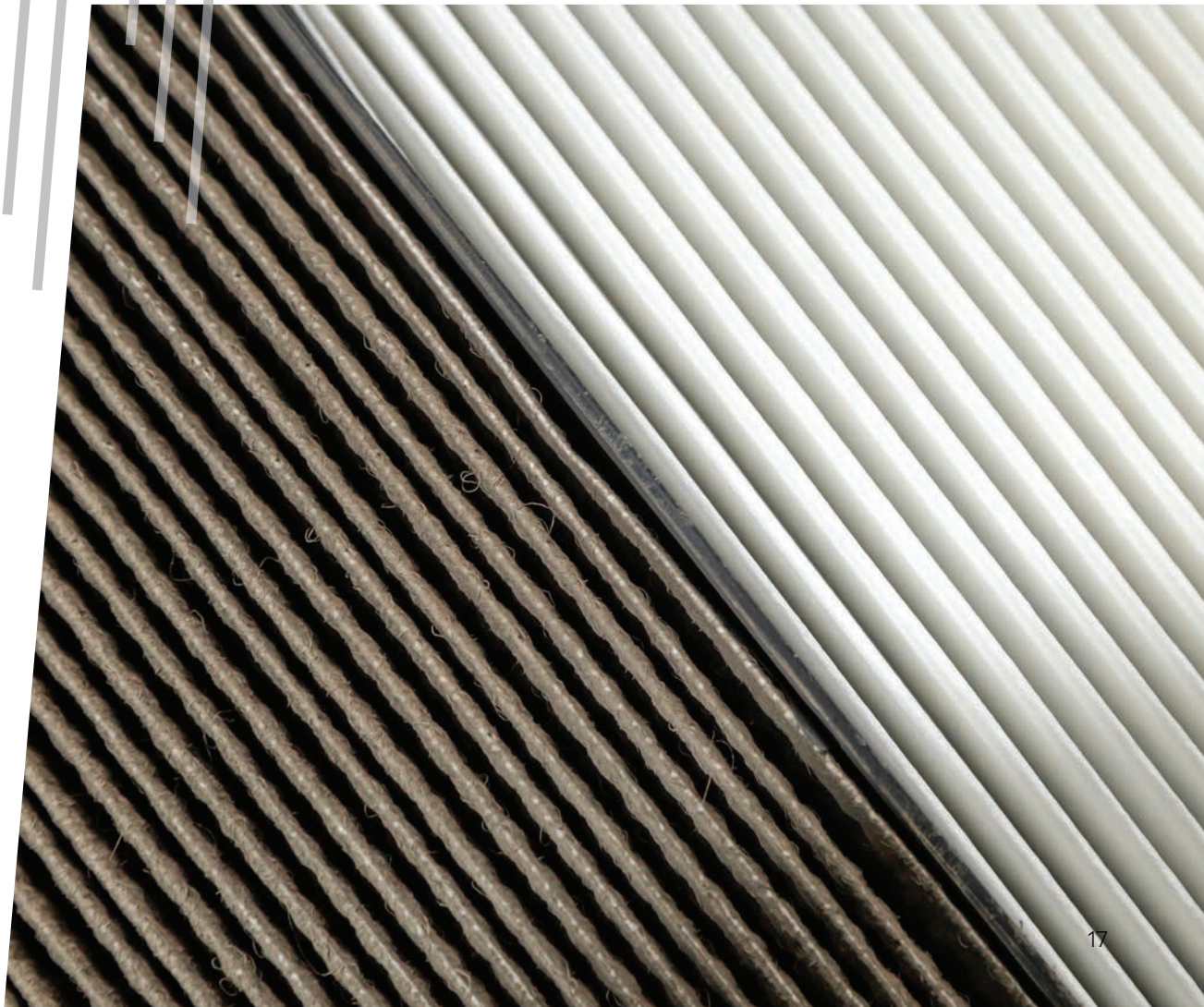

.....

# HRV *Flow* Range

## Wall-mounted

Point-wise systems for retrofits on existing buildings



.....  
: **FlowEASY**<sup>TM</sup>



.....  
: **FlowPLUS**<sup>TM</sup>/PLUS-R



.....  
: **FlowULTRA**/ULTRA-R

## Wall recessed

Recessed wall-mounted systems for renovations and new buildings



.....  
: **Flow30**<sup>TM</sup> : **Flow40**<sup>TM</sup>



.....  
: **Flow120**



.....  
: **FlowC120**

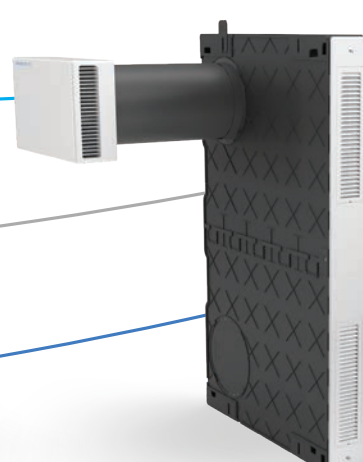

.....  
: **FlowMANHATTAN**

## For redevelopment

Patented HRV system installed in the exterior cladding, with no impact on the facade



See all  
product  
details

## Community

Systems for air exchange and sanitisation in schools, offices, laboratories, small shops

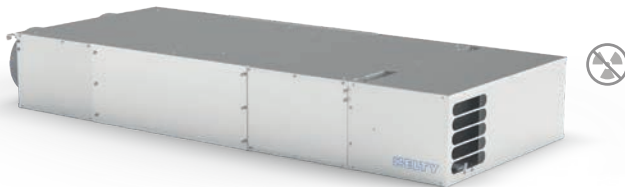

Flw400<sup>Steel</sup>/400-R<sup>Steel</sup>

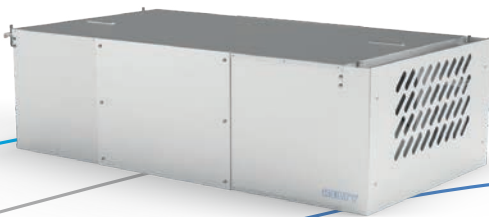

Flw600<sup>Steel</sup>



Flw800/M800/800<sup>Steel</sup>/800-R<sup>Steel</sup>



Flw1000/M1000/1000<sup>Steel</sup>

# Flow-R line

Dedicated HRV solutions for effective radon risk mitigation

The **Helty Flow-R line** features an innovative series of **decentralised HRV solutions** dedicated to **radon risk mitigation**. The R Line includes four different models of ventilation units, designed to effectively meet the needs of risk reduction in homes and businesses:

- // **FlowPLUS-R | FlowULTRA-R**  
ideal for wall-mounted retrofit applications in homes
- // **Flow400-R**  
perfect for installation in small classrooms and offices
- // **Flow800-R**  
designed for retrofit installation in large environments, such as schools and open-plan offices.

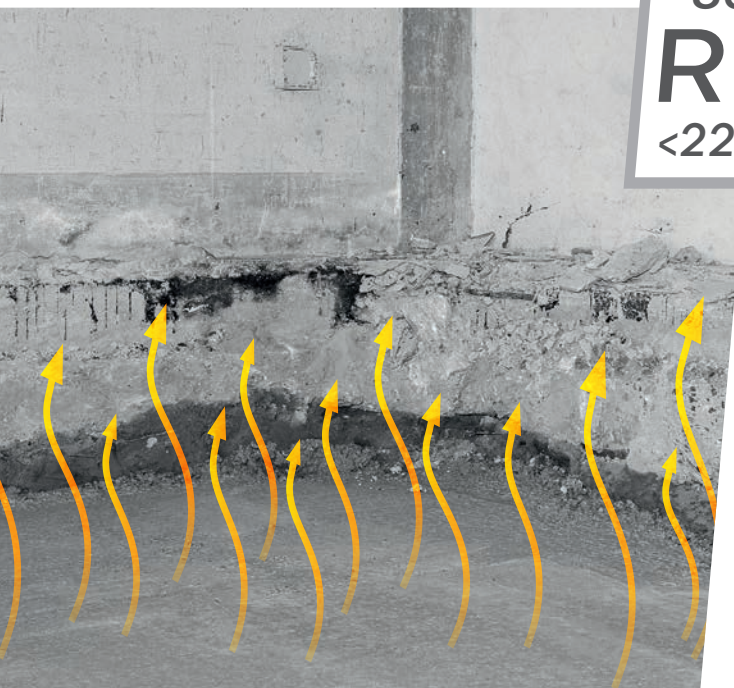

## HRV for smart radon risk management

Helty's Radon Line products are designed to provide an **effective** and **minimally invasive solution** for **radon risk management**. HRV units can be remotely programmed, setting customised operating scenarios. Alternatively, they can be calibrated on-site according to the radon gas emissivity detected in the environment.



Using the WiFi **cloud panel**, the Flow-R versions allow remote management using the Hely Home app. The **Radon Scenarios** option allows the best management of **radon risk mitigation** through an array of customised unit settings. The intake and extraction airflow rates can be diversified by programming the imbalance of the unit while maintaining

the unbalance settings at different speeds. For these models, the **Radon Monitor sensor** for active gas monitoring, allowing an adaptive and automatic response based on user-programmable intervention thresholds, is also available as an option.



Radon monitor

.....

# Wall-Mounted HRV

Decentralised systems for retrofitting small rooms in existing buildings



Model	FlowEASY		FlowPLUS		FlowPLUS-R	FlowULTRA	FlowULTRA-R
	Enthalpy <sup>(1)</sup>	Sensible <sup>(1)</sup>	Enthalpy <sup>(1)</sup>	Sensible <sup>(1)</sup>	Enthalpy <sup>(1)</sup>	Enthalpy <sup>(1)</sup>	Enthalpy <sup>(1)</sup>
Heat exchanger							
Night function	●	●	●	●	●	●	●
Hyperventilation	-	-	●	●	●	●	●
Filter replacement alert	●	●	●	●	●	●	●
Comfort function	-	-	●	●	●	●	●
Humidity sensor	-	-	●	●	-	●	-
External CO <sub>2</sub> / IAQ sensors	-	-	compatible	compatible	compatible	compatible	compatible
Radon sensor	-	-	-	-	compatible	-	compatible
Free-cooling / Free-heating	-	-	●	●	●	●	●
Remote control	●	●	●	●	●	●	●
Panel LED On/Off	●	●	●	●	●	●	●
Helty Home App	-	-	●	●	●	●	●
Tested according to UNI EN 13141-8	●	●	●	●	●	●	●
<b>STD</b>	1VMC02025	1VMC02026	1VMC02027	1VMC02030	1VMC02034	1VMC02011	1VMC02016
<b>Shutter</b>	-	-	1VMC02028	1VMC02031	-	-	-
<b>Shutter + Preheating</b>	-	-	1VMC02029	1VMC02032	-	-	-

1. Counter-flow.





# Flow EASY™

## Compact and functional

The new **FlowEASY** has been developed to offer a **simple yet effective** decentralised heat recovery ventilation solution, providing continuous air exchange with **minimal impact on the budget**. It is the most affordable option in the Helyt range, ideal for those seeking **reliable, cost-effective ventilation as an alternative to ducted systems**.

A compact, updated design and air flow rates designed for rooms up to **20m<sup>2</sup>** make FlowEASY the **most cost-effective and reliable choice** for retrofit applications in small domestic settings, ensuring high performance in terms of sound insulation as well.

Beneath the new casing is a HRV unit optimised in

both structure and function: FlowEASY features a **simplified operating system**, with just **two air exchange speeds** and an intuitive control interface for an even simpler and more immediate user experience. The system with **ePM2.5 65% (F7) filter** ensures a constant supply of fresh, purified air by capturing fine particulate matter, pollen and impurities, offering **superior protection compared to standard push-pull units**.

### Vertical retrofit installation with no trade-offs

For the first time, FlowEASY is available in two variants – with a traditional enthalpy heat exchanger, or with the **new sensible heat exchanger** – to choose the solution best suited to your specific climate requirements. The wall-mounted version now favours **vertical installation**, which accents the new design and allows for the management of condensate drainage on the model with the sensible heat exchanger. Maintenance is minimal, consisting mainly of replacing the filter when indicated by the LED on the control panel.

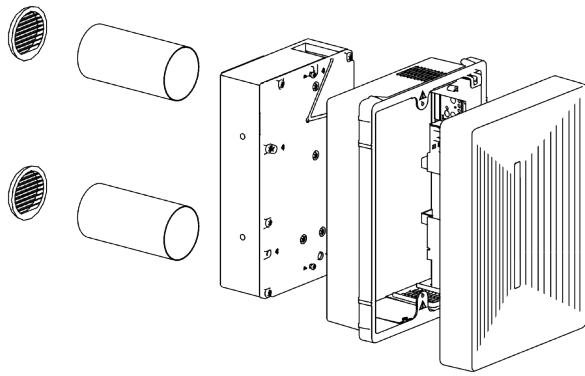

Available also with sensible heat recovery



It is easy to control it from anywhere in the room using the included infrared remote control



**91%**

Heat recovery efficiency



**17.5** dB(A)

Minimum sound pressure



**30** m<sup>3</sup>/h

Maximum airflow



**ePM2.5 65% + Coarse90%**

Intake air filtration



**-27.8** kWh/m<sup>2</sup>a

SEC energy consumption (temperate climate)

Energy efficiency class **B**



## Technical data

Functions and features	UOM	FlowEASY	
		Enthalpy <sup>(1)</sup>	Sensible <sup>(1)</sup>
Heat exchanger			
Night function		●	●
Filter replacement alert		●	●
Remote control		●	●
Panel LED On/Off		●	●
Tested according to UNI EN 13141-8		●	●
Airflow rate	m <sup>3</sup> /h	8/15/30	
Flow adjustment		night + 2 stages	
Power consumption	W	2/5/11.5	
Specific power input	W/m <sup>2</sup> /h	0.25/0.33/0.38	
Supply voltage	V AC	230	
Operating voltage <sup>(2)</sup>	V DC	24	
Max. current consumption <sup>(3)</sup>	A	0.1	
Weight	kg	7	
Product dimensions (W x H x D)	mm	339 x 467 x 144	
Core-drilled holes	mm	2x Ø80	
Installation orientation		horizontal or vertical	vertical
Heat recovery efficiency	%	91/85/78	
Sound power level <sup>(4)</sup>	dB(A)	29/33.5/45	
Sound pressure <sup>(5)</sup>	dB(A)	17.5/22/33.5	
Dn,e,W (facade noise abatement)	dB	45	
Intake filter <sup>(6)</sup>		ePM2.5 65% + Coarse90%	
Extraction filter <sup>(6)</sup>		Coarse 70%	
Modbus RTU rs485		No	
Reference climate		cold / temperate / warm	
Energy efficiency class (cold / temperate / hot)		A+ / B / F	
SEC (cold / temperate / warm)	kWh/m <sup>2</sup> a	-61.9 / -27.8 / -5.6	
Kit		card with QR-code digital manuals, installation template, HRV filter, 2 white external grilles, 2 air ducts (Ø80, 500mm), wall mounting kit, remote control with batteries	card with QR-code digital manuals, installation template, HRV filter, 2 white external grilles, 2 air ducts (Ø80, 500mm), wall mounting kit, remote control with batteries, condensate drain kit
Code		1VMC02025	1VMC02026

1. Counter-flow.

2. The power supply unit provided enables operation with power supply of 230 V AC. To be connected during installation.

3. With 230 V AC supply voltage

4. According to UNI EN ISO 3744.

5. Measured in a 30 m<sup>2</sup> semi-anechoic environment at a distance of 3 m.

6. UNI EN ISO 16890-1.

## Accessories and spare parts

Article	Code
FlowEASY/PLUS template	1VMC99211
Filter ePM1 80% + Coarse70%x10 Flow40	1VMC99772
Filter ePM1 80% + Coarse70%x30 Flow40	1VMC99773
Filter ePM2.5 65% + Coarse70%x10 Flow40	2VMC00000098
Filter ePM2.5 65% + Coarse70%x30 Flow40	2VMC00000092
External grilles Ø100mm plastic	1PVCVMC00011
External grilles Ø80mm plastic	1PVCVMC00020
Foldable grilles, white aluminium Ø100	4VMC00000762
Gasket Ø100mm wall-mounted HRV	1VMC99027
Weak walls fixing plate	1VMC99216
Remote control	4VMC00000900
Pipe + grilles Ø100mm L 500mm x2pcs.	1VMC99901
Pipe + grilles Ø80mm L 500mm x2pcs.	1VMC99048
Window-side + HRV wall grilles	1VMC99130

## Flow-head charts

- A** Head            **1** Super-minimum speed (night)    **3** Speed 2  
**B** Flow rate        **2** Speed 1

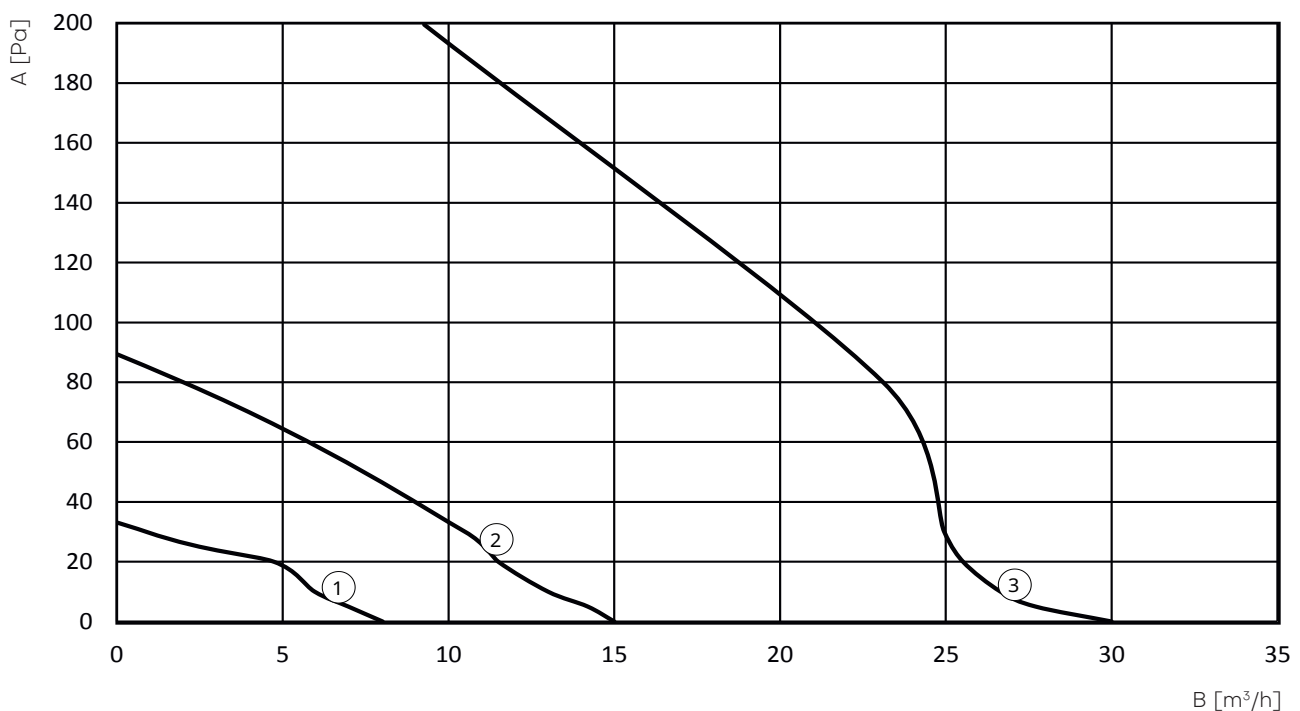

.....



## Dimensional drawings

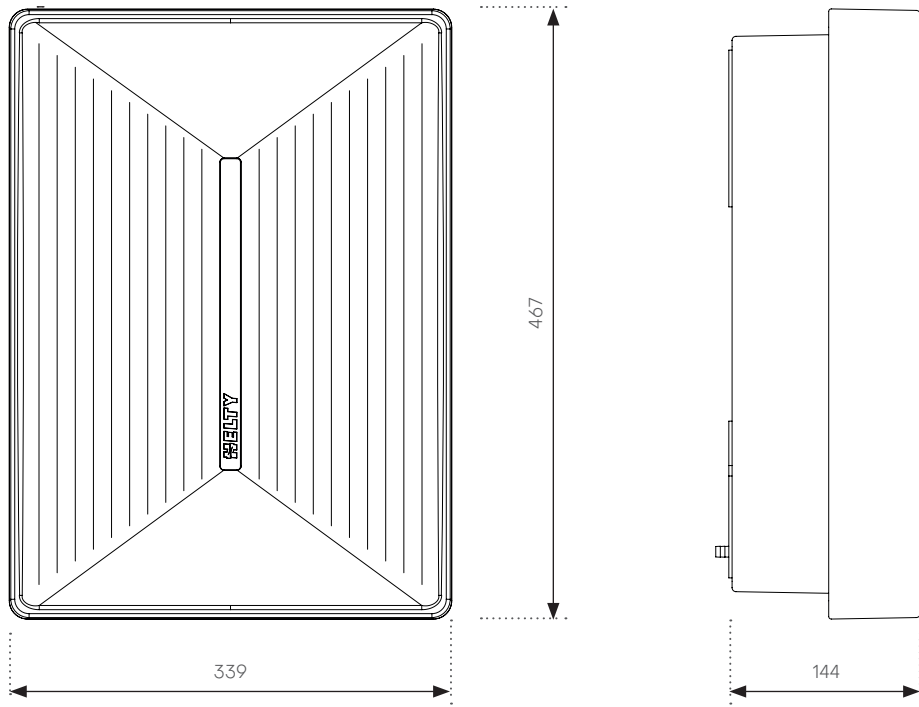

## Recommended buffer zones

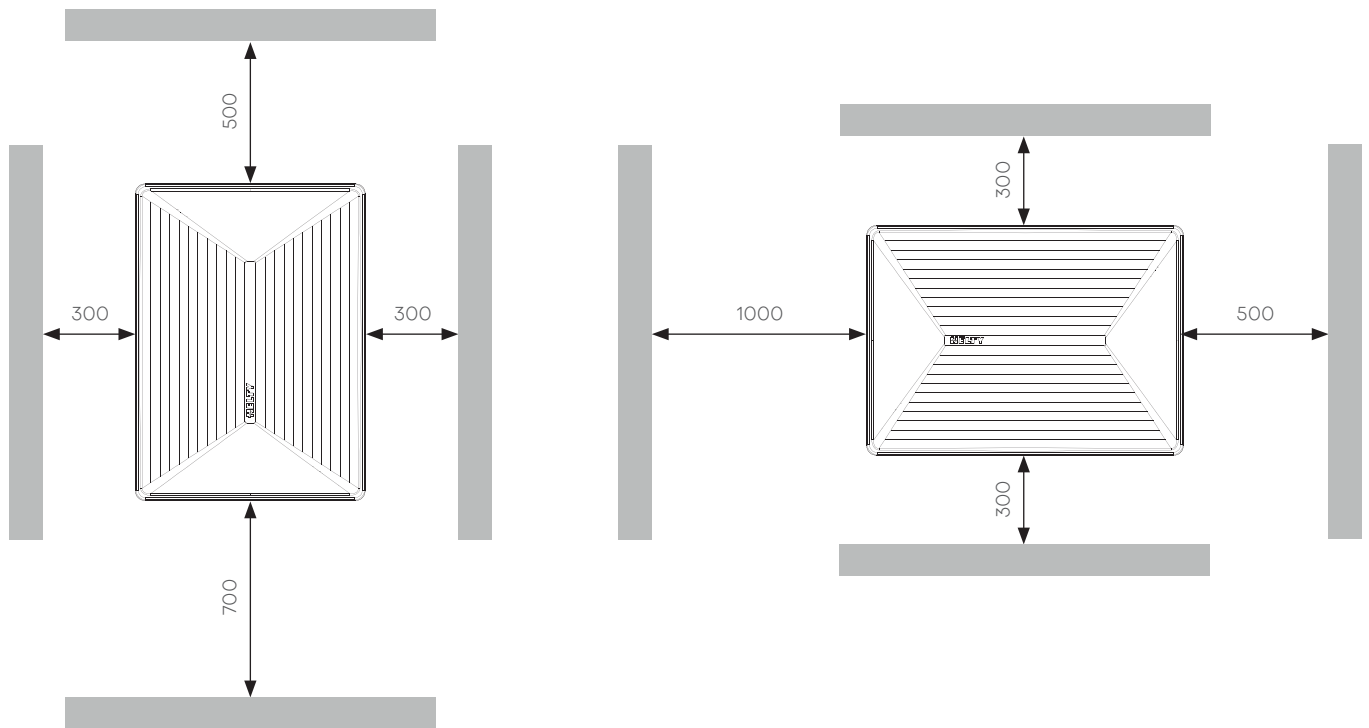





# Flow PLUS™ / PLUS-R

*Advanced, quiet, designed  
for superior performance*

Helty FlowPLUS is the flagship model of the **wall-mounted HRV range**: a comprehensive solution designed to ensure continuous ventilation, high air quality and maximum thermal and humidity comfort in homes.

The unit constantly renews the indoor air, filtering the incoming air with a standard **ePM2.5 65% (F7)** filter and keeps humidity in check using an **integrated hygrometric sensor**, which automatically adjusts ventilation to prevent condensation and mould. The 2026 range marks an evolution in both appearance and functionality. The new cover further enhances the looks of FlowPLUS, making it even more discreet and easy to integrate. **Configurations with shutters and preheating** are also available.

Its compact dimensions and minimalist design echo the style of contemporary lamps and furnishings. For the first time, FlowPLUS is available in **two different versions**: with an **enthalpy heat exchanger** or with the new **sensible heat exchanger**. The enthalpy heat exchanger recovers both heat and humidity, whilst the sensible version focuses solely on heat recovery, making it ideal for milder climates. For **radon gas mitigation**, the **FlowPLUS-R** version is available, equipped with remote connectivity via the Helty Home app, for air quality monitoring and even more efficient ventilation management.



*Vertical installation  
and smart  
management*

Compact and easy to install, FlowPLUS requires only two Ø80 mm holes in the external masonry and an electrical connection, with no need for invasive work. The new model is designed primarily for **vertical installation**, which showcases its new design. In addition to the on-board controls and the remote control, the unit can be operated remotely via the **Helty Home app**, allowing you to monitor temperature and humidity, program ventilation levels and create customised automatic scenarios.

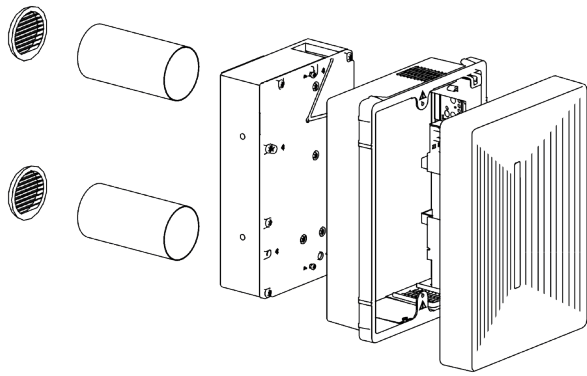

Sensors for automatic humidity management



Available also with sensible heat recovery



Modbus RTU rs485 integration



**91%**

Heat recovery efficiency



**17.5** dB(A)

Minimum sound pressure



**42** m<sup>3</sup>/h

Maximum airflow



**ePM2.5 65% + Coarse 90%**

Intake air filtration



**-37.9** kWh/m<sup>2</sup>a

SEC energy consumption (temperate climate)

Energy efficiency class **A**



## Technical data

Functions and features	UOM	FlowPLUS		FlowPLUS-R
		Enthalpy <sup>(1)</sup>	Sensible <sup>(1)</sup>	Enthalpy <sup>(1)</sup>
Heat exchanger				
Night function		●	●	●
Hyperventilation		●	●	●
Filter replacement alert		●	●	●
Comfort function		●	●	●
Humidity sensor		●	●	-
External CO <sub>2</sub> / IAQ sensors		compatible	compatible	compatible
Radon sensor		-	-	compatible
Free-cooling / Free-heating		●	●	●
Remote control		●	●	●
Panel LED On/Off		●	●	●
Helty Home App		●	●	●
Tested according to UNI EN 13141-8		●	●	●
Airflow rate	m <sup>3</sup> /h	8/10/17/26/37/42 <sup>(2)</sup>		
Flow adjustment		night + 4 stages + hyperventilation		
Power consumption	W	2/3.6/5.5/9/17.5/20 <sup>(2)</sup>		
Specific power input	W/m <sup>2</sup> /h	0.25/0.35/0.32/0.35/0.47/0.48 <sup>(2)</sup>		
Supply voltage	V AC	230		
Operating voltage <sup>(3)</sup>	V DC	24		
Max. current consumption <sup>(4)</sup>	A	0.15 / 0.25 <sup>(9)</sup>		0.15
Heater power level <sup>(9)</sup>	W	40		-
Weight	kg	8		
Product dimensions (W x H x D)	mm	339 x 467 x 144		
Core-drilled holes	mm	2x Ø80		
Installation orientation		horizontal or vertical	vertical	horizontal or vertical
Heat recovery efficiency	%	91/91/80/76/70/68 <sup>(2)</sup>		
Sound power <sup>(5)</sup>	dB(A)	29/29.5/39.9/42/50.7/53.7 <sup>(2)</sup>		
Sound pressure <sup>(6)</sup>	dB(A)	17.5/18/23.4/30.5/39.2/42.2 <sup>(2)</sup>		
Dn,e,W (facade noise abatement)	dB	45		
Intake filter <sup>(7)</sup>		ePM2.5 65% + Coarse90%		
Extraction filter <sup>(7)</sup>		Coarse 70%		
Modbus RTU rs485		Yes <sup>(8)</sup>		
Reference climate		cold / temperate / warm		
Energy efficiency class (cold / temperate / hot)		A+ / A / E		
SEC (cold / temperate / warm)	kWh/m <sup>2</sup> a	-74.1 / -37.9 / -14.6		
Kit		card with QR-code digital manuals, installation template, HRV filter, 2 white external grilles, 2 air ducts (Ø80, 500mm), wall mounting kit, remote control with batteries	card with QR-code digital manuals, installation template, HRV filter, 2 white external grilles, 2 air ducts (Ø80, 500mm), wall mounting kit, remote control with batteries, condensate drain kit	
STD		1VMC02027	1VMC02030	1VMC02034
Shutter		1VMC02028	1VMC02031	-
Shutter + Preheating		1VMC02029	1VMC02032	-

1. Counter-flow.

2. In hyperventilation mode.

3. The power supply unit provided enables operation with power supply of 230 V AC. To be connected during installation.

4. With 230 V AC supply voltage.

5. According to UNI EN ISO 3744.

 6. Measured in a 30 m<sup>2</sup> semi-anechoic environment at a distance of 3 m.

7. UNI EN ISO 16890-1.

8. The control panel functions are lost.

9. Shutter + Preheating.

## Accessories and spare parts

Article	Code
IAQ monitor	4VMC00000903
WiFi Hely CO <sub>2</sub> monitor	4VMC00000902
FlowEASY/PLUS template	1VMC99211
Filter ePM1 80% + Coarse70%x10 Flow40	1VMC99772
Filter ePM1 80% + Coarse70%x30 Flow40	1VMC99773
Filter ePM2.5 65% + Coarse70%x10 Flow40	2VMC00000098
Filter ePM2.5 65% + Coarse70%x30 Flow40	2VMC00000092
External grilles Ø100mm plastic	1PVCVMC00011
External grilles Ø80mm plastic	1PVCVMC00020
Foldable grilles, white aluminium Ø100	4VMC00000762
Gasket Ø100mm wall-mounted HRV	1VMC99027
Weak walls fixing plate	1VMC99216
Radon monitor	4VMC00000901
Remote control	4VMC00000900
Pipe + grilles Ø100mm L 500mm x2pcs.	1VMC99901
Pipe + grilles Ø80mm L 500mm x2pcs.	1VMC99048
Window-side + HRV wall grilles	1VMC99130

## Flow-head charts

- A** Head      **1** Super-minimum speed (night)      **3** Speed 2      **5** Speed 4  
**B** Flow rate      **2** Speed 1      **4** Speed 3      **6** Hyperventilation

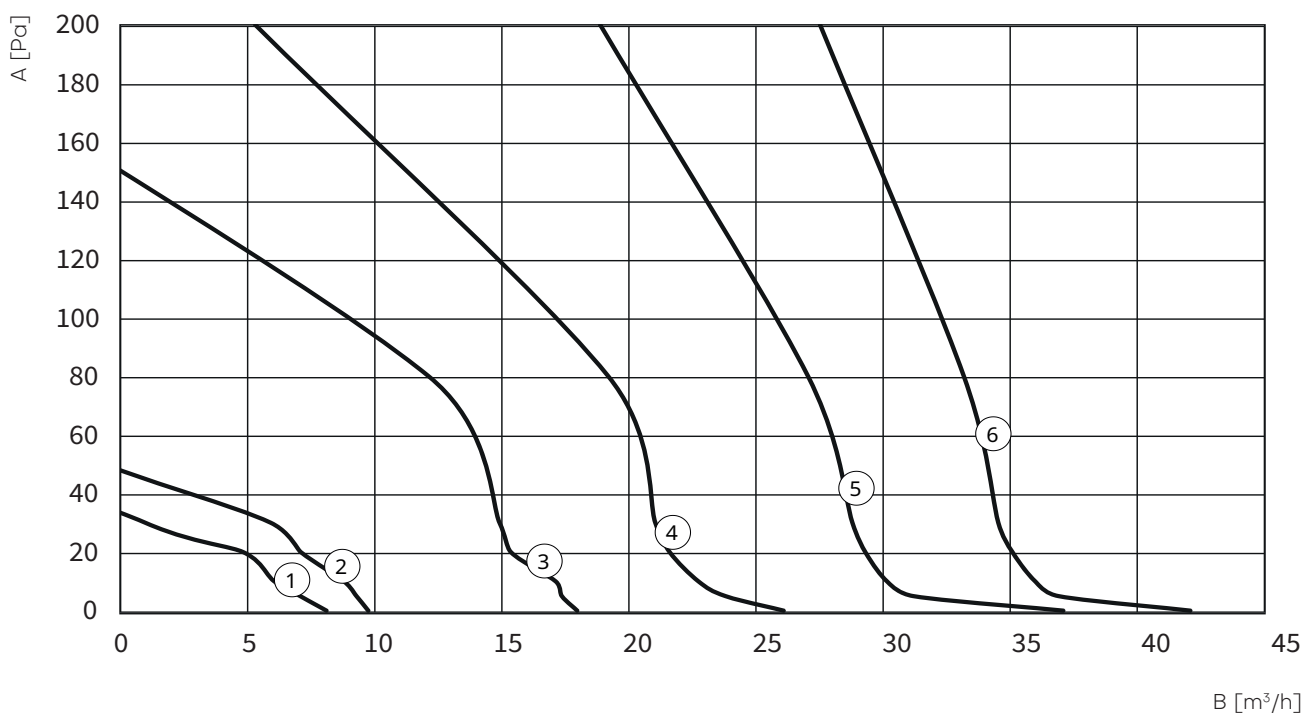

.....



## Dimensional drawings

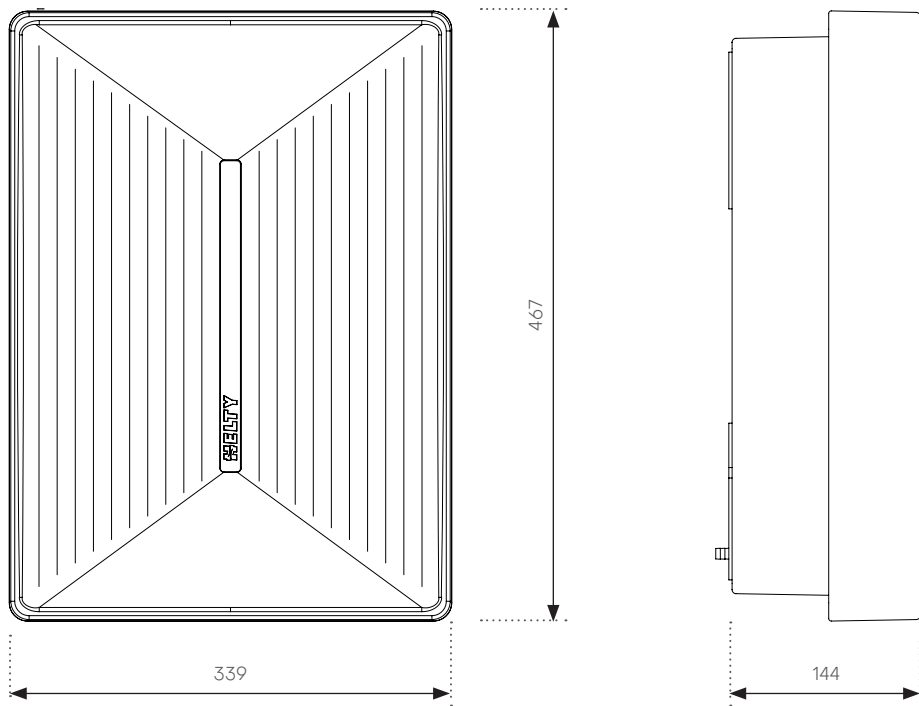

## Recommended buffer zones

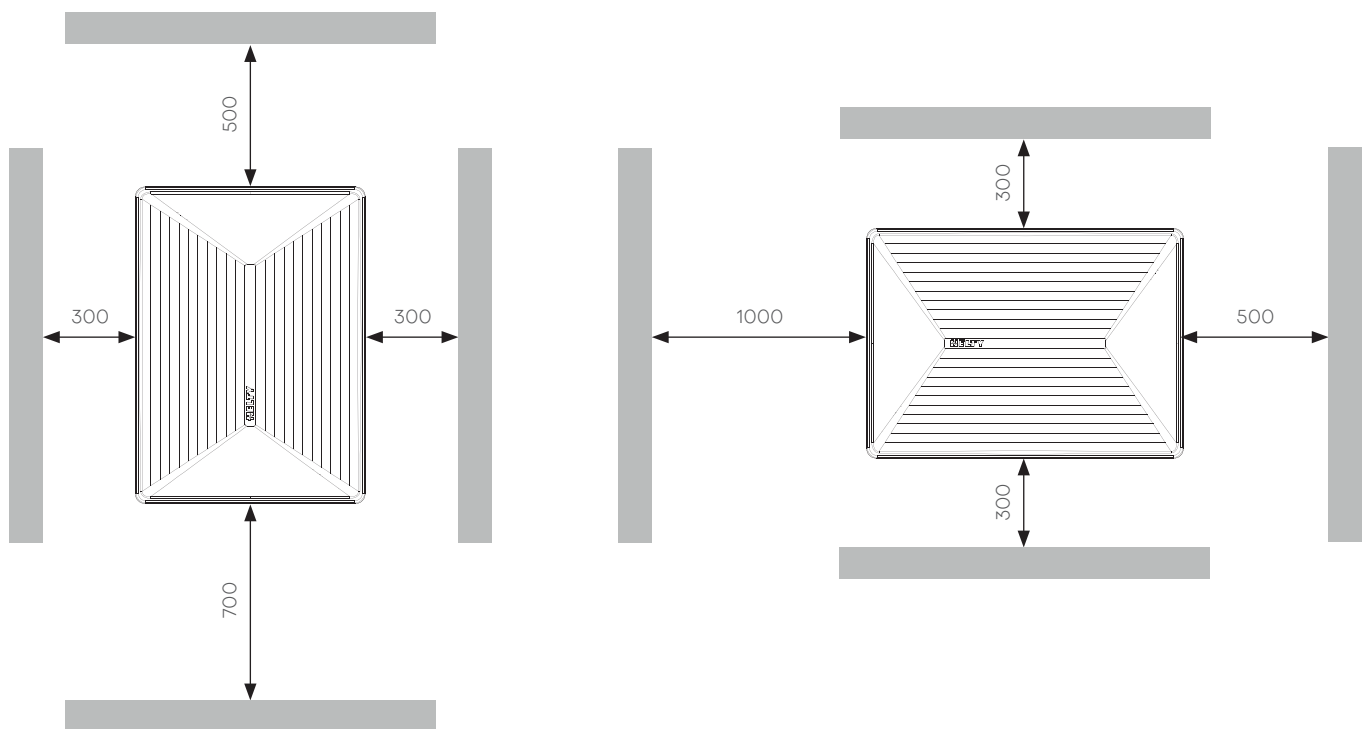

## Wall-mounted HRV

Wall-mounted HRV systems allow plug-and-play installation. Installation requires two small 80-mm coring holes in the masonry, inserting and sealing the tubes in the masonry section, fixing the unit to the wall with pressure screws, electrical connection and positioning the grilles outside.

**The grilles can be installed directly from inside the house using the 100 mm ducting kit (optional).**

Condensate drainage must be managed in models with sensible heat exchanger. See the instruction manual for more details.

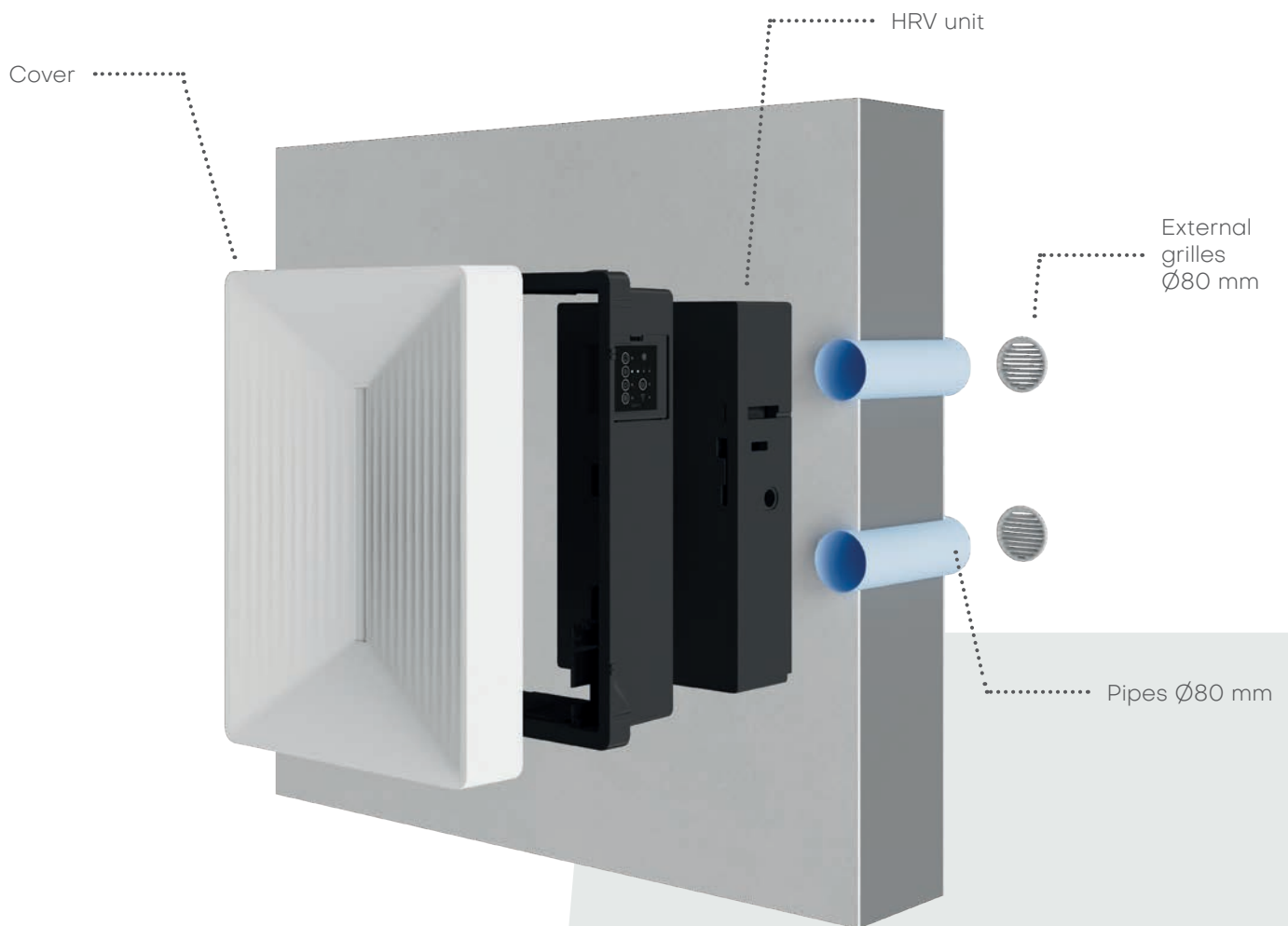



# Flow ULTRA/ULTRA-R

*Ideal for HRV retrofit in living spaces and small offices*

FlowULTRA is the evolution of retrofit HRV with wall-mounted installation dictated by the need to **ensure proper air exchange in recently upgraded contexts**, while safeguarding the energy efficiency provided by the insulation of the building envelope. A continuous dual-flow ventilation unit designed to serve individual rooms, with **adjustable airflow rates between 15 and 120 m<sup>3</sup>/h**. Installed with two 100 mm coring holes, FlowULTRA is supplied as standard with a white ABS cover for a neat connection to the existing environment. A solution designed to **meet the needs for healthy air in medium-sized rooms**, small offices, professional offices, medical surgeries and open-plan spaces.

The continuous exchange action, combined with the very high air filtration capacity of the **ePM2.5 65% filter (F7)**, ensures a healthier and more comfortable environment, preventing particulates, smog, spores, pollen and allergens from entering from outside. Energy savings are guaranteed by the **heat recovery unit with efficiency of up to 88%**. Effective in preventing condensation and mould, FlowULTRA is also ideal for **application in basements and cellars**. The air pipes can be partially ducted using a special optional kit to maximise installation flexibility.



*Your trusted ally against radon, manageable via app*

The ULTRA-R version is designed to help contain the radon risk by effectively diluting the gas. This solution is particularly suitable for retrofit applications in basements and all high-risk contexts. FlowULTRA and ULTRA-R can be combined with optional CO<sub>2</sub>, IAQ and radon sensors to provide comprehensive monitoring of indoor air quality parameters. The HRV unit can be managed remotely via the Hely Home app for setting customised scenarios and exporting data history.

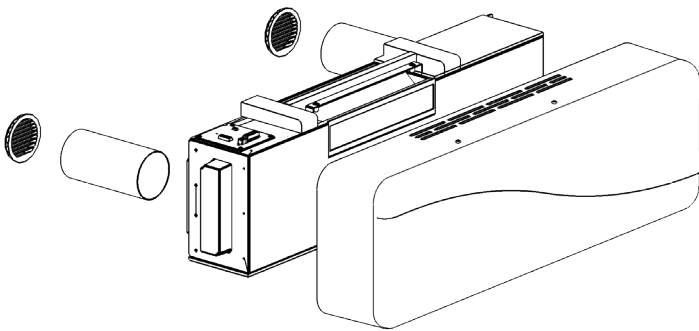

Sensors for automatic humidity management



Modbus RTU rs485 integration



It is easy to control it from anywhere in the room using the included infrared remote control



**88%**

Heat recovery efficiency



**19.5** dB(A)

Minimum sound pressure



**120** m<sup>3</sup>/h

Maximum airflow



**ePM2.5 65% + Coarse 60%**

Intake air filtration



**-36.7** kWh/m<sup>2</sup>a

SEC energy consumption (temperate climate)

Energy efficiency class **A**



## Technical data

Functions and features	UOM	FlowULTRA	FlowULTRA-R
Heat exchanger		Enthalpy <sup>(1)</sup>	Enthalpy <sup>(1)</sup>
Night function		●	●
Hyperventilation		●	●
Filter replacement alert		●	●
Comfort function		●	●
Humidity sensor		●	-
External CO <sub>2</sub> / IAQ sensors		compatible	compatible
Radon sensor		-	compatible
Free-cooling / Free-heating		●	●
Remote control		●	●
Panel LED On/Off		●	●
Helty Home App		●	●
Tested according to UNI EN 13141-8		●	●
Airflow rate	m <sup>3</sup> /h	13/30/45/60/80/120 <sup>(2)</sup>	
Flow adjustment		night + 4 stages + hyperventilation	
Power consumption	W	3/6/9/13/16.3/39 <sup>(2)</sup>	
Specific power input	W/m <sup>2</sup> /h	0.23/0.2/0.2/0.22/0.29/0.46 <sup>(2)</sup>	
Supply voltage	V AC	230	
Operating voltage <sup>(3)</sup>	V DC	24	
Max. current consumption <sup>(4)</sup>	A	0.3	
Weight	kg	12	
Product dimensions (W x H x D)	mm	1000 x 320 x 180	
Core-drilled holes	mm	2x Ø100	
Installation orientation		horizontal	
Heat recovery efficiency	%	88/82/75/72/68/57 <sup>(2)</sup>	
Sound power <sup>(5)</sup>	dB(A)	31/36/43/48/55/63 <sup>(2)</sup>	
Sound pressure <sup>(6)</sup>	dB(A)	19.5/24.5/31.5/36.5/43.5/51.5 <sup>(2)</sup>	
Dn,e,W (facade noise abatement)	dB	45	
Intake filter <sup>(7)</sup>		ePM2.5 65% + Coarse60%	
Extraction filter <sup>(7)</sup>		Coarse 70%	
Modbus RTU rs485		Yes <sup>(8)</sup>	
Reference climate		cold / temperate / warm	
Energy efficiency class (cold / temperate / hot)		A+ / A / E	
SEC (cold / temperate / warm)	kWh/m <sup>2</sup> a	-74.5 / -39 / -16.1	
Kit		card with QR-code digital manuals, installation template, HRV filter, 2 white external grilles, 2 air ducts (Ø100, 500mm), wall mounting kit, remote control with batteries	card with QR-code digital manuals, installation template, HRV filter, 2 white external grilles, 2 air ducts (Ø100, 500mm), wall mounting kit, remote control with batteries, condensate drain kit
STD		1VMC02011	1VMC02016

1. Counter-flow.

2. In hyperventilation mode

3. The power supply unit provided enables operation with power supply of 230 V AC. To be connected during installation.

4. With 230 V AC supply voltage.

5. According to UNI EN ISO 3744.

6. Measured in a 30 m<sup>2</sup> semi-anechoic environment at a distance of 3 m.

7. UNI EN ISO 16890-1.

8. The control panel functions are lost.

## Accessories and spare parts

Article	Code
Pipe adapter 120x60 – Ø100 x2 FlowULTRA	1VMC99186
Wall floor adapter FlowULTRA	1VMC99135
IAQ monitor	4VMC00000903
WiFi Hely CO <sub>2</sub> monitor	4VMC00000902
FlowULTRA template	4MKT00000868
Filter Coarse 60% x10 Flow120	1VMC06014
Filter Coarse 60% x5 Flow120	1VMC06015
Filter ePM1 80% x10 Flow120	1VMC06019
Filter ePM1 80% x5 Flow120	1VMC06018
Filter ePM2.5 65% + Coarse60%x10 Flow120	1VMC06012
Filter ePM2.5 65% + Coarse60%x5 Flow120	1VMC06013
External grilles Ø100mm plastic	1PVCVMC00011
Foldable grilles, white aluminium Ø100	4VMC00000762
Radon monitor	4VMC00000901
Remote control	4VMC00000900
Pipe + grilles Ø100mm L 500mm x2pcs.	1VMC99901

## Flow-head charts

- A** Head            **1** Super-minimum speed (night)    **3** Speed 2            **5** Speed 4  
**B** Flow rate       **2** Speed 1                                    **4** Speed 3            **6** Hyperventilation

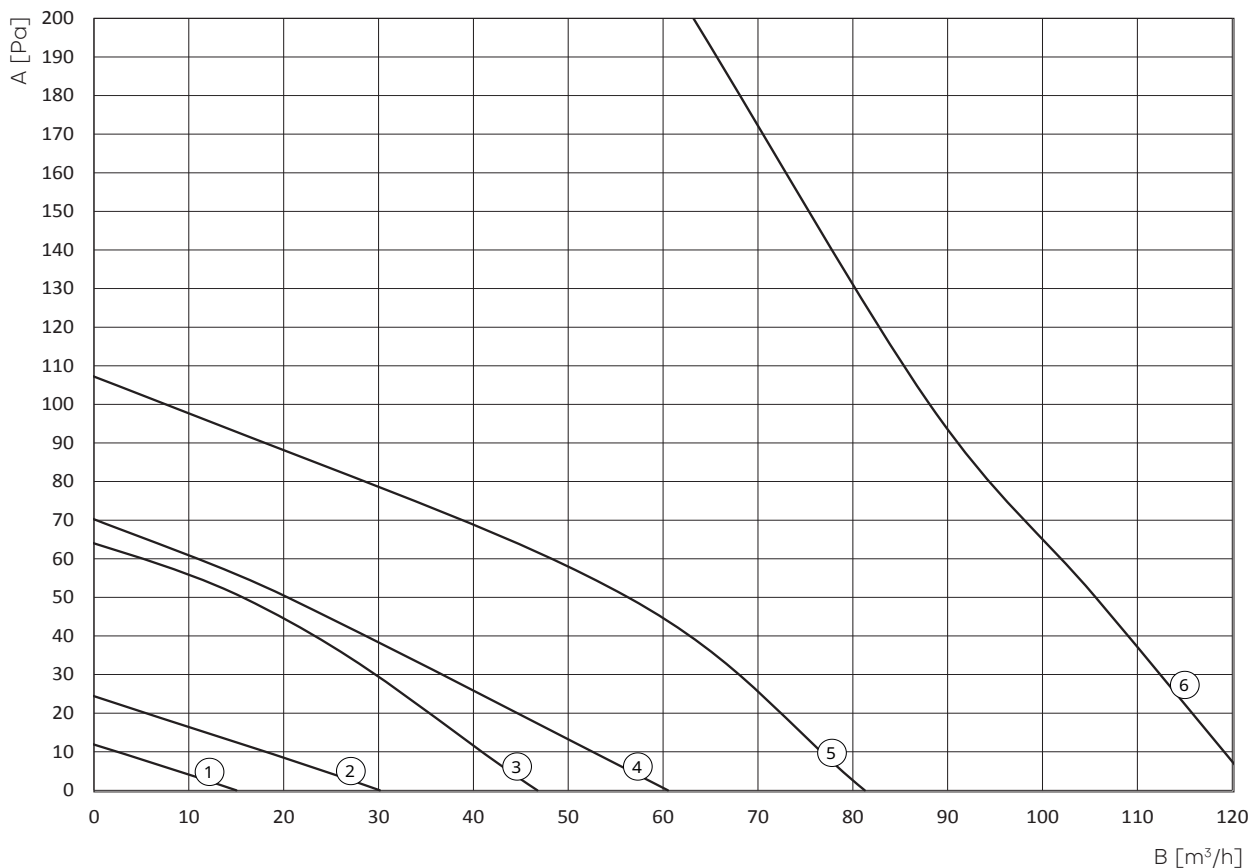

.....



## Dimensional drawings

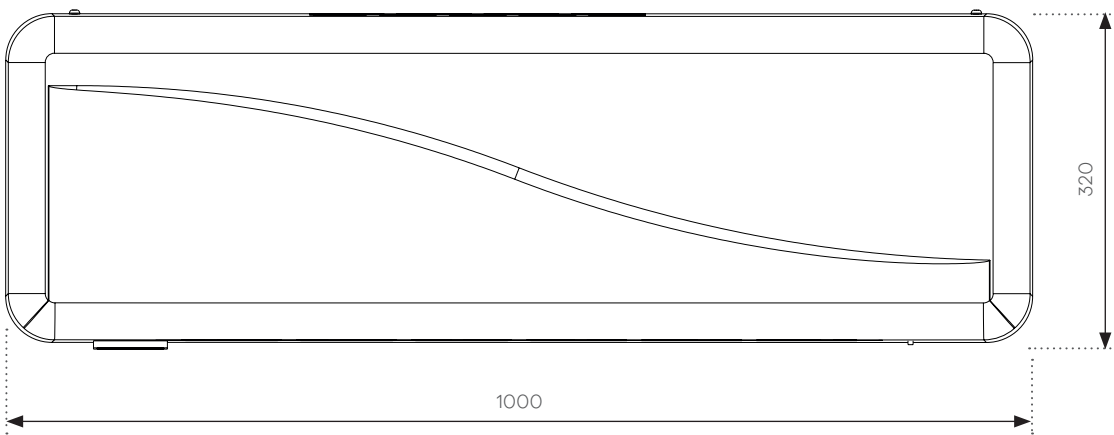
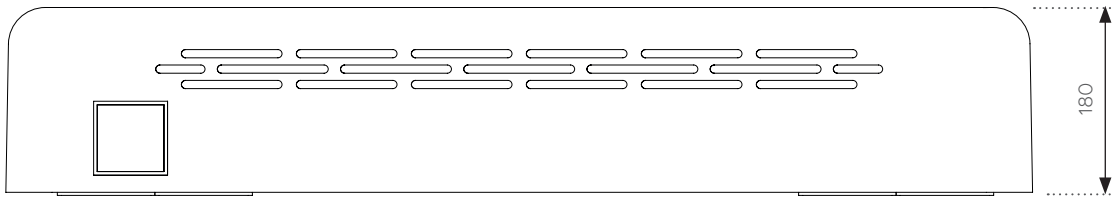

## Recommended buffer zones

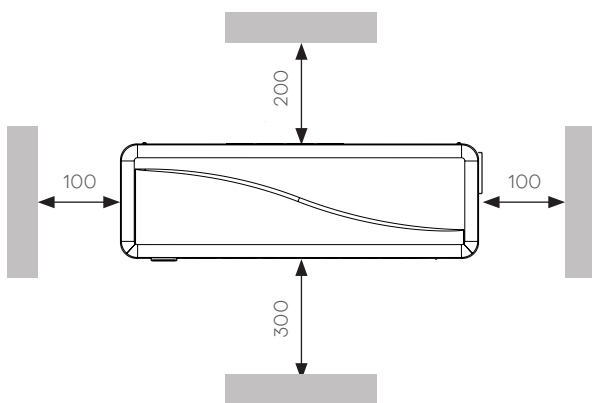



# Extractor XTRA

*Ideal for quickly  
extracting stale air  
from bathrooms*

For situations where odours, exhaust air and fumes must be extracted quickly in small and medium-sized rooms, such as bathrooms, toilets, utility rooms, kitchens, cellars, laundries, etc. Made of high-quality, UV-resistant ABS in a modern design with a smooth front panel, it can be installed on the wall or ceiling.

Functions and features	UOM	Extractor	
		XTRA	XTRA+
Version		XTRA	XTRA+
Timer		-	●
Humidity sensor		-	●
Check valve		-	●
Airflow rate	m <sup>3</sup> /h		88
Power consumption	W		14
Supply voltage	V AC	220-240 single-phase	
Max. current consumption <sup>(1)</sup>	A	0.09	
Weight	kg	0.6	
Product dimensions (W x H x D)	mm	152 x 120 x 30	
Core-drilled holes	mm	Ø100	
Installation orientation		horizontal	
Sound power	dB(A)	53	
IP protection rating		34	
Kit		installation manual	
<b>Code</b>		<b>4XTRA00090000</b>	<b>4XTRA00090001</b>

1. With 230 V AC supply voltage.

.....

# Wall recessed HRV

Recessed systems for new buildings, renovations and energy upgrade projects

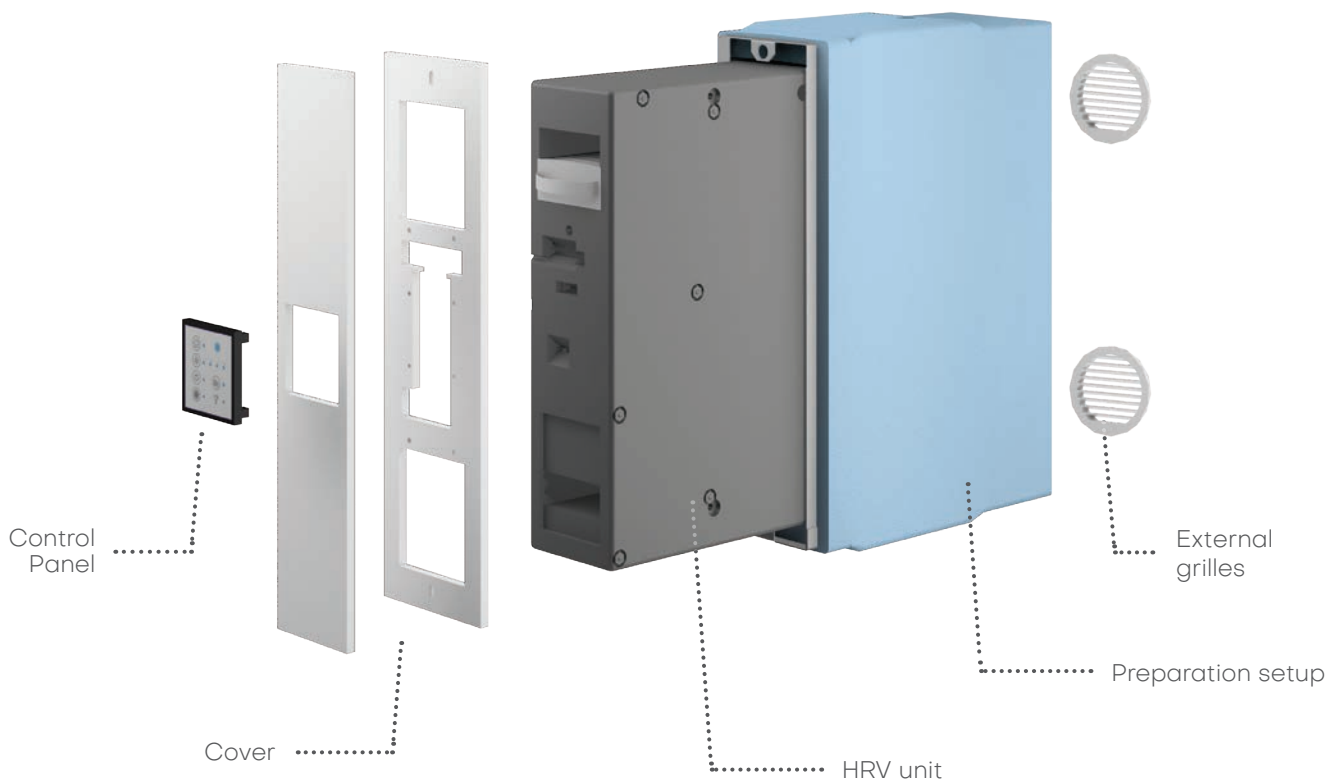

A HRV unit plus the corresponding preparation setup, cover and controller is needed to compose the wall-recessed HRV system, except for Flow30, which is supplied with an ABS cover as standard.

## HRV unit



Model	Flow30		Flow40		Flow120	Flow120H	FlowC120
	Enthalpy <sup>(1)</sup>	Sensible <sup>(1)</sup>	Enthalpy <sup>(1)</sup>	Sensible <sup>(1)</sup>	Enthalpy <sup>(1)</sup>	Enthalpy <sup>(1)</sup>	Enthalpy <sup>(1)</sup>
Heat exchanger							
Night function	●	●	●	●	●	●	●
Hyperventilation	-	-	●	●	●	●	●
Filter replacement alert	●	●	●	●	●	●	●
Comfort function	-	-	●	●	●	●	●
Humidity sensor	-	-	●	●	●	●	●
External CO <sub>2</sub> /IAQ sensors <sup>(2)</sup>	-	-	compatible	compatible	compatible	compatible	compatible
Free-cooling / Free-heating	-	-	●	●	●	●	●
Remote control	compatible	compatible	compatible	compatible	compatible	compatible	compatible
Panel LED On/Off	●	●	●	●	●	●	●
Helty Home app <sup>(2)</sup>	-	-	compatible	compatible	compatible	compatible	compatible
Tested according to UNI EN 13141-8	●	●	●	●	●	●	●
STD	1VMC02017	1VMC02018	1VMC02019	1VMC02022	1VMC02007	1VMC02014	1VMC02009
Shutter	-	-	1VMC02020	1VMC02023	-	-	-
Shutter + Preheating	-	-	1VMC02021	1VMC02024	-	-	-

## Preparation setups



Model	Flow30/40	Flow30/40	Flow120		Flow120H	FlowC120
Outlet	facade	window-side	facade	window-side	facade	facade
Code	1VMC03010	1VMC99214	1VMC03007	1VMC03009	1VMC03007	1VMC03008

## Cover



	Flow40 Blind sheet metal	Flow40 Blind white plexi	Flow40 Blind blackplexi	Flow40 Flush	Flow40 sheet metal	Flow40 white plexi	Flow40 blackplexi
Code	1VMC99195	1VMC99193	1VMC99194	1VMC99207	1VMC99000	1VMC99001	1VMC99002



	Flow120 Blind sheet metal	Flow120 Blind white plexi	Flow120 Blind blackplexi	Flow120 sheet metal	Flow120 white plexi	Flow120 blackplexi
Code	1VMC99188	1VMC99187	1VMC99203	1VMC99098	1VMC99099	1VMC99104

1. Counter-flow.  
2. With Cloud Control Panel.



# Flow30™

## The compact and economical essential HRV

Helty Flow30 is the most affordable decentralised, wall-recessed solution in the range, specifically designed to provide effective **basic ventilation at a low cost**. The ideal choice for **optimising construction site operations and reducing system complexity** in contexts requiring economies of scale and **design simplicity**. The Flow30 simplifies ventilation management by offering a **pre-configured setup**, with basic functions and just two operating speeds.

Ideal for rooms up to 20 m<sup>2</sup>, the Flow30 aims to provide a **valid and cost-effective alternative to ducted systems**, ensuring superior **sound insulation**, heat recovery and filtration performance compared to push-pull systems. It can be installed in a pre-fitted configuration and completed with the HRV unit and ABS cover at a later stage, making Flow30 a **functional, low-cost solution to protect against mould and humidity**.



*Sensible or enthalpy heat exchanger for bespoke comfort*

Flow30 offers the choice between two types of heat exchanger – **sensible or enthalpy** – to best adapt to the climate and requirements of the space to be ventilated. Two different technologies, designed to ensure indoor comfort in various situations, promoting the **healthiness of the interior spaces**.

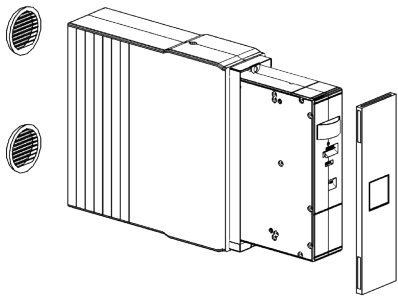

Flow30

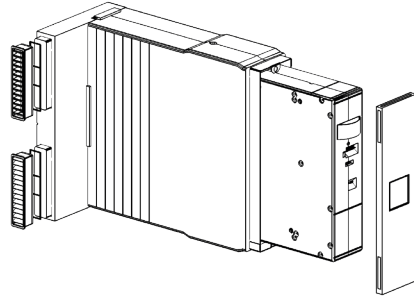

Flow30 windows-side outlet



Zero footprint solution: completely recessed into the masonry.



**91%**

Heat recovery efficiency



**14.5** dB(A)

Minimum sound pressure



**30** m<sup>3</sup>/h

Maximum airflow



**ePM2.5 65% + Coarse90%**

Intake air filtration



**-27.8** kWh/m<sup>2</sup>a

SEC energy consumption (temperate climate)



Energy efficiency class **B**

## HRV unit technical data

Functions and features	UOM	Flow30	
		Enthalpy <sup>(1)</sup>	Sensible <sup>(1)</sup>
Heat exchanger			
Night function		●	●
Filter replacement alert		●	●
Remote control		compatible	compatible
Panel LED On/Off		●	●
Tested according to UNI EN 13141-8		●	●
Airflow rate	m <sup>3</sup> /h	8/15/30	
Flow adjustment		night + 2 stages	
Power consumption	W	2/5/11.5	
Specific power input	W/m <sup>2</sup> /h	0.25/0.33/0.38	
Supply voltage	V AC	230	
Operating voltage <sup>(2)</sup>	V DC	24	
Max. current consumption <sup>(3)</sup>	A	0.1	
HRV unit weight	kg	4	
HRV unit dimensions (W x H x D)	mm	108 x 408 x 253	
Preparation setup dimensions (W x H x D)	mm	145 x 504 x 517	
Installation orientation		horizontal or vertical	vertical
Heat recovery efficiency	%	91/85/78	
Sound power level <sup>(4)</sup>	dB(A)	29/33.5/45	
Sound pressure <sup>(5)</sup>	dB(A)	14.5/19.5/29.5	
Dn,e,W (facade noise abatement)	dB	45	
Intake filter <sup>(6)</sup>		ePM2.5 65% + Coarse90%	
Extraction filter <sup>(6)</sup>		Coarse 70%	
Reference climate		cold / temperate / warm	
Energy efficiency class (cold / temperate / hot)		A+ / B / F	
SEC (cold / temperate / warm)	kWh/m <sup>2</sup> a	-61.9 / -27.8 / -5.6	
Kit		card with QR-code digital manuals, power supply, control panel, airtight gasket, ABS cover	card with QR-code digital manuals, power supply, control panel, airtight gasket, ABS cover, condensate drain kit
<b>STD</b>		<b>1VMC02017</b>	<b>1VMC02018</b>

1. Counter-flow.

2. The power supply unit provided enables operation with power supply of 230 V AC. To be connected during installation.

3. With 230 V AC supply voltage.

4. According to UNI EN ISO 3744.

5. Measured in a 30 m<sup>2</sup> semi-anechoic environment at a distance of 3 m.

6. UNI EN ISO 16890-1.

## Accessories and spare parts

Article	Code
Grille adapter 120x60mm - Ø100mm x2	1VMC99058
Adapter preparation setup Flow40	1VMC99240
Filter ePM1 80% + Coarse70%x10 Flow40	1VMC99772
Filter ePM1 80% + Coarse70%x30 Flow40	1VMC99773
Filter ePM2.5 65% + Coarse70%x10 Flow40	2VMC00000098
Filter ePM2.5 65% + Coarse70%x30 Flow40	2VMC00000092
External Drip-proof grilles Ø100mm	1VMC99213
External grilles Ø100mm plastic	1VMC99212
Slim exterior grilles + mesh	1VMC00000237
Insulation setup Flow40	1VMC99059
Flow40 protection panel	1VMC99051
Flow40 preparation setup	1VMC03010
Remote control	4VMC00000900
External slim grilles with facade outlet	1VMC99070
Window-side outlet + slim external grilles	1VMC99214

## Flow-head charts

A Head                    1 Super-minimum speed (night)                    3 Speed 2  
 B Flow rate                2 Speed 1

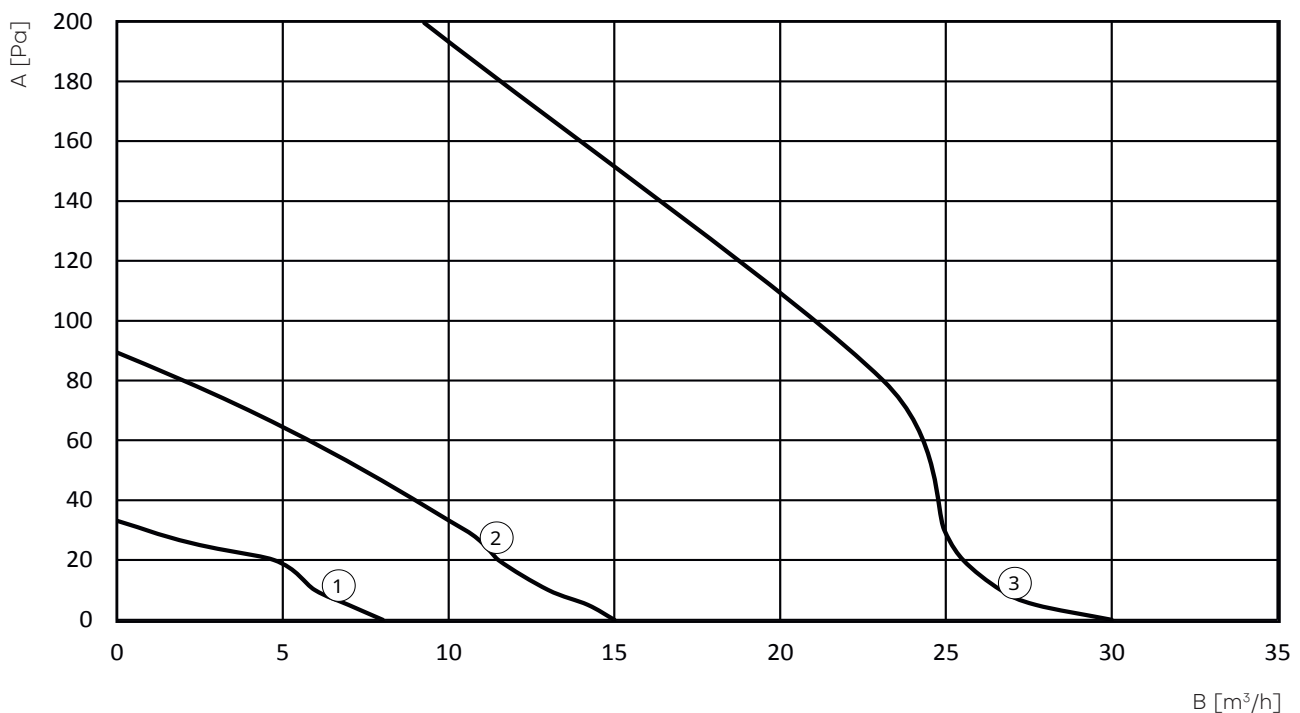

.....



## Dimensional drawings

### Flow30

Facade output

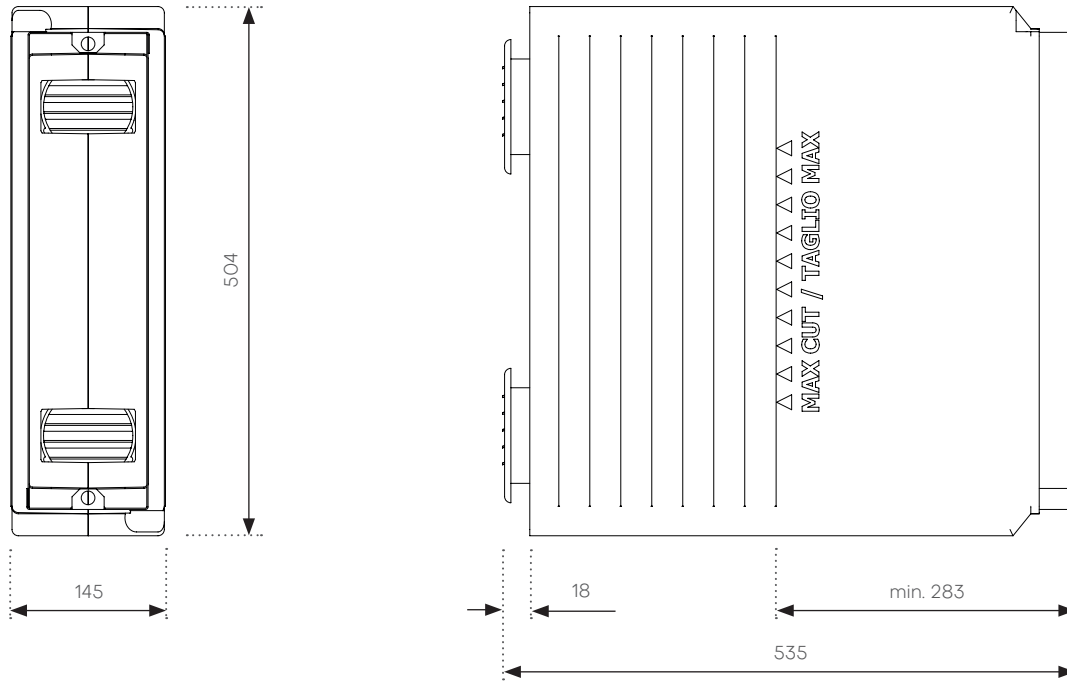

### Recommended buffer zones

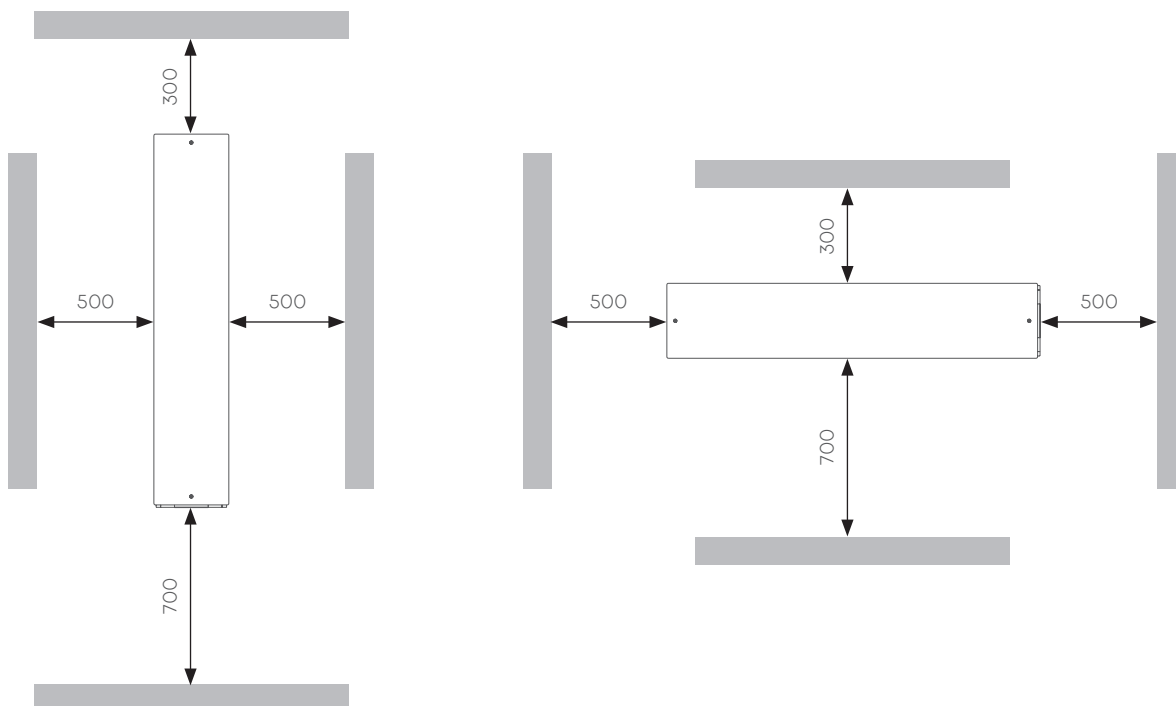

## Dimensional drawings

### Flow30

Window-side outlet

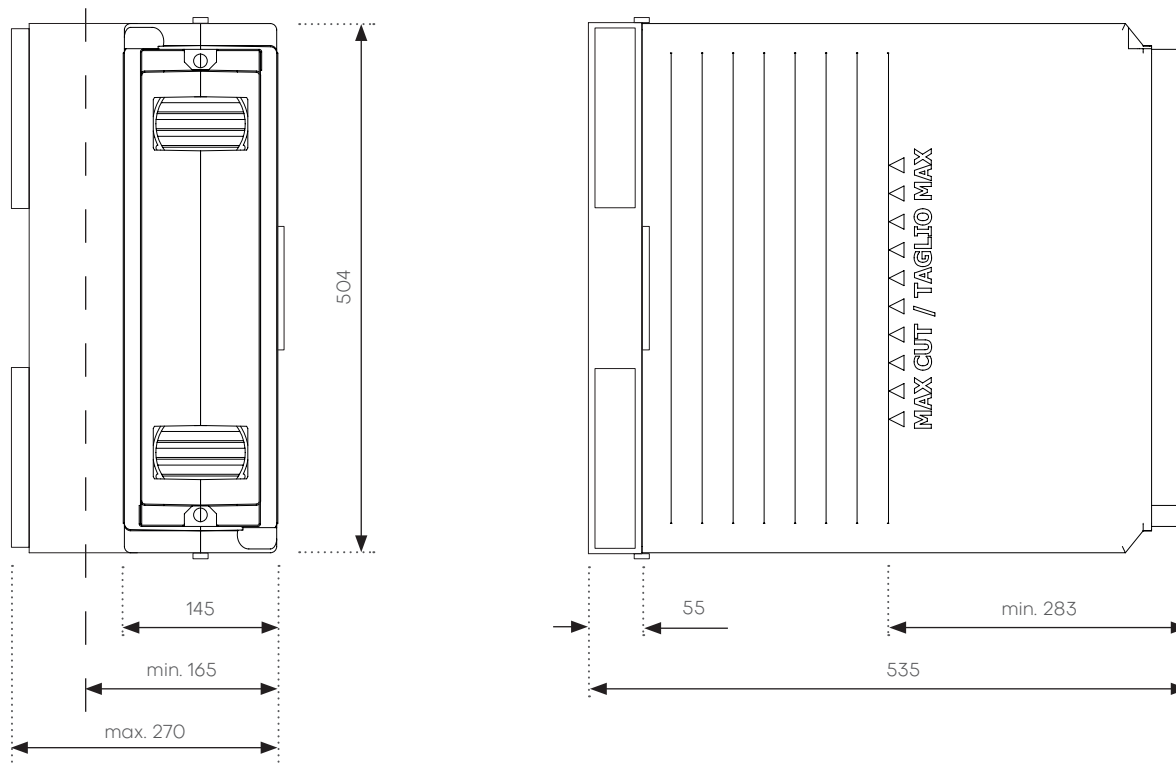

### Recommended buffer zones

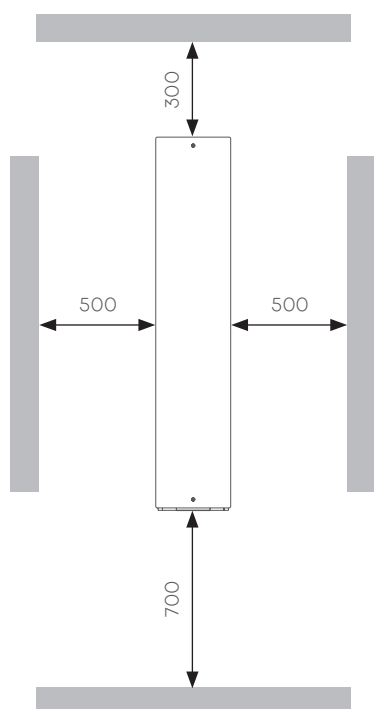



# Flow40™

Efficient, discreet and configurable

Flow40 has been updated and **expands its configuration options** to adapt to any customisation. Ideal for new builds and renovations, this decentralised flush-mounted system offers a **concealed and modular solution**. It requires no pipework or false ceilings, leaving only the cover visible. The available cover versions include metal – either blind or with a keypad – or white or black PMMA, also blind or with a keypad. These are complemented by a flush-mounted, paintable cover for situations where a completely invisible solution is required. The machine body is housed in **preparation setup, adaptable to walls** from 304 to 535 mm, which can be fitted during construction and completed with HRV units and covers even at a later date.

There are also new developments in heat exchanger technology, with the **option to choose between enthalpy (for harsher climates) or sensible** (ideal for temperate climates). Flow40 is available in **standard versions, with shutters, or with shutters and preheating**. It is also possible to select the position of the control panel: **wall-mounted, on a 503 box, or on the unit itself**. The standard hygrometric sensor automatically adjusts ventilation based on humidity and the **double ePM2.5 65% (F7) + Coarse 90% (G4) / Coarse 70% (G2) filter** ensures effective air purification from smog, spores, pollen and allergens, whilst maintaining the heat exchanger efficiency.



*Invisible and smart with app control*

The Flow40 version with **windows-side outlets** integrates the grilles directly into the side of the window, making the **system even more invisible**. The machine can be paired with **optional CO<sub>2</sub> and IAQ** sensors for an even more accurate reading of indoor air quality parameters and personalised air exchange management. The **Helty Home app** can be used to manage ventilation remotely, program scenarios, control multiple units and simplify operation.

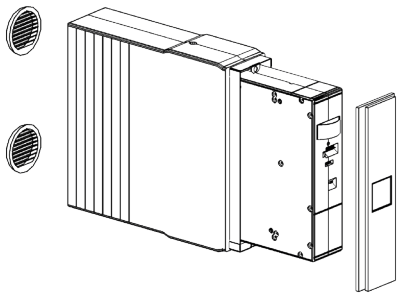

**Flow40**

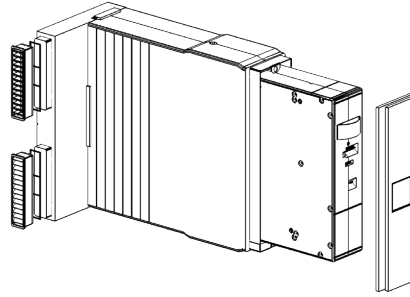

**Flow40** windows-side outlet



Sensors for automatic humidity management



Modbus RTU rs485 integration



Zero footprint solution: completely recessed into the masonry



**91%**

Heat recovery efficiency



**14.5** dB(A)

Minimum sound pressure



**42** m<sup>3</sup>/h

Maximum airflow



**ePM2.5 65% + Coarse90%**

Intake air filtration



**-37.9** kWh/m<sup>2</sup>a

SEC energy consumption (temperate climate)

Energy efficiency class **A**



.....

## HRV unit technical data

Functions and features	UOM	Flow40	
		Enthalpy <sup>(1)</sup>	Sensible <sup>(1)</sup>
Heat exchanger			
Night function		●	●
Hyperventilation		●	●
Filter replacement alert		●	●
Comfort function		●	●
Humidity sensor		●	●
External CO <sub>2</sub> / IAQ sensors <sup>(2)</sup>		compatible	compatible
Free-cooling / Free-heating		●	●
Remote control		compatible	compatible
Panel LED On/Off		●	●
Helty Home app <sup>(2)</sup>		compatible	compatible
Tested according to UNI EN 13141-8		●	●
Airflow rate	m <sup>3</sup> /h	8/10/17/26/37/42 <sup>(3)</sup>	
Flow adjustment		night + 4 stages + hyperventilation	
Power consumption	W	2/3.6/5.5/9/17.5/20 <sup>(3)</sup>	
Specific power input	W/m <sup>2</sup> /h	0.25/0.35/0.32/0.35/0.47/0.48 <sup>(3)</sup>	
Supply voltage	V AC	230	
Operating voltage <sup>(4)</sup>	V DC	24	
Max. current consumption <sup>(5)</sup>	A	0.15 / 0.25 <sup>(11)</sup>	
Heater power level <sup>(8)</sup>	W	40	
Weight	kg	4 / 4.1 <sup>(10)</sup> / 4.2 <sup>(11)</sup>	
HRV unit dimensions (W x H x D)	mm	108 x 408 x 253	
Preparation setup dimensions (W x H x D)	mm	145 x 504 x 517	
Installation orientation		horizontal or vertical	vertical
Heat recovery efficiency	%	91/91/80/76/70/68 <sup>(3)</sup>	
Bypass (free cooling/free heating)		electronic automatic	
Sound power <sup>(6)</sup>	dB(A)	26/26.5/32.4/37.8/46/49 <sup>(3)</sup>	
Sound pressure <sup>(7)</sup>	dB(A)	14.5/15/20.9/26.3/34.5/37.5 <sup>(3)</sup>	
Dn,e,w (facade noise abatement)	dB	45	
Intake filter <sup>(8)</sup>		ePM2.5 65% + Coarse90%	
Extraction filter <sup>(8)</sup>		Coarse 70%	
Modbus RTU rs485		Yes <sup>(9)</sup>	
Reference climate		cold / temperate / warm	
Energy efficiency class (cold / temperate / hot)		A+ / A / E	
SEC (cold / temperate / warm)	kWh/m <sup>2</sup> a	-74.1 / -37.9 / -14.6	
Kit		card with QR-code digital manuals, power supply, airtight gasket, microswitch	card with QR-code digital manuals, power supply, airtight gasket, microswitch, condensate drain kit
STD		1VMC02019	1VMC02022
Shutter		1VMC02020	1VMC02023
Shutter + Preheating		1VMC02021	1VMC02024

1. Counter-flow.

2. With Cloud Control Panel.

3. In hyperventilation mode.

4. The power supply unit provided enables operation with power supply of 230 V AC. To be connected during installation.

5. With 230 V AC supply voltage

6. According to UNI EN ISO 3744.

7. Measured in a 30 m<sup>2</sup> semi-anechoic environment at a distance of 3 m.

8. UNI EN ISO 16890-1.

9. The control panel functions are lost.

10. Shutter.

11. Shutter + Preheating.

## Accessories and spare parts

Article	Code
Cable coupler RJ10 + cable 5m	1VMCA9913
Grille adapter 120x60mm - Ø100mm x2	1VMC99058
White Bt Livingnow Adapter for Recessed Control Panel	1VMC99096
Black Bt Livingnow Adapter for Recessed Control Panel	1VMC99180
Adapter preparation setup Flow40	1VMC99240
WiFi Hely air quality monitor <sup>(1)</sup>	4VMC00000903
WiFi Hely CO <sub>2</sub> monitor <sup>(1)</sup>	4VMC00000902
Flow40 sheet metal blind cover	1VMC99195
Flow40 PMMA white blind cover	1VMC99193
Flow40 PMMA black blind cover	1VMC99194
Flow40 flush cover	1VMC99207
Flow40 sheet metal cover	1VMC99000
Flow40 PMMA white cover	1VMC99001
Flow40 PMMA black cover	1VMC99002
Filter ePM1 80% + Coarse70%x10 Flow40	1VMC99772
Filter ePM1 80% + Coarse70%x30 Flow40	1VMC99773
Filter ePM2.5 65% + Coarse70%x10 Flow40	2VMC00000098
Filter ePM2.5 65% + Coarse70%x30 Flow40	2VMC00000092
External Drip-proof grilles Ø100mm	1VMC99213
External grilles Ø100mm plastic	1VMC99212
Slim external grilles + mesh	1VMC00000237
Insulation setup Flow40	1VMC99059
Cloud blue built-in control panel + 300mm cable	1VMC99154
Flow40 Cloud blue blind control panel	1VMC99204
Cloud blue built-in control panel + 5m cable	1VMC99202
STD blue built-in control panel + 5m cable	1VMC99201
Cloud blue control black panel + 300mm cable	1VMC99243
STD blue control black panel + 500mm cable	1VMC99241
STD blue control panel + 500mm cable	1VMC99153
Flow40 protection panel	1VMC99051
Flow40 preparation setup	1VMC03010
60mm extension sheet metal panel	1VMC99069
Remote control	4VMC00000900
External slim grilles with facade outlet	1VMC99070
Window-side outlet + slim external grilles	1VMC99214

1. Cloud Control Panel required.

.....

## Flow-head charts

- |                    |                                      |                  |                           |
|--------------------|--------------------------------------|------------------|---------------------------|
| <b>A</b> Head      | <b>1</b> Super-minimum speed (night) | <b>3</b> Speed 2 | <b>5</b> Speed 4          |
| <b>B</b> Flow rate | <b>2</b> Speed 1                     | <b>4</b> Speed 3 | <b>6</b> Hyperventilation |

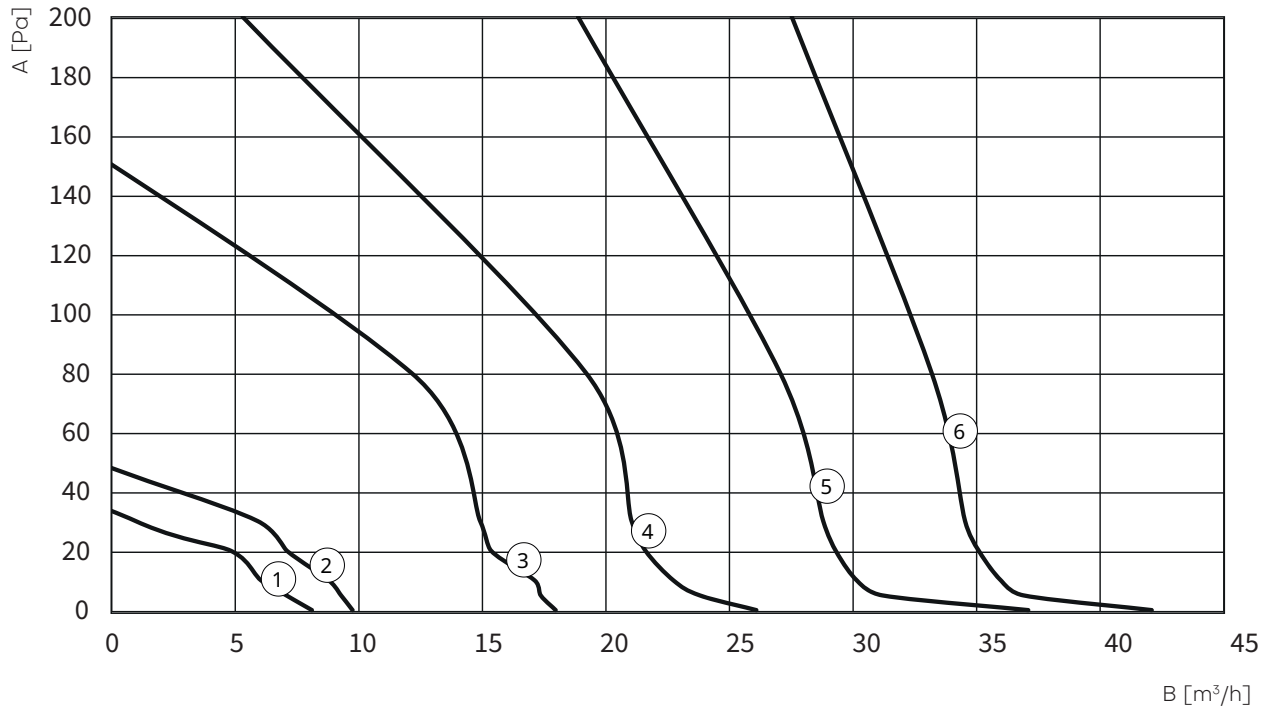

## Recommended buffer zones

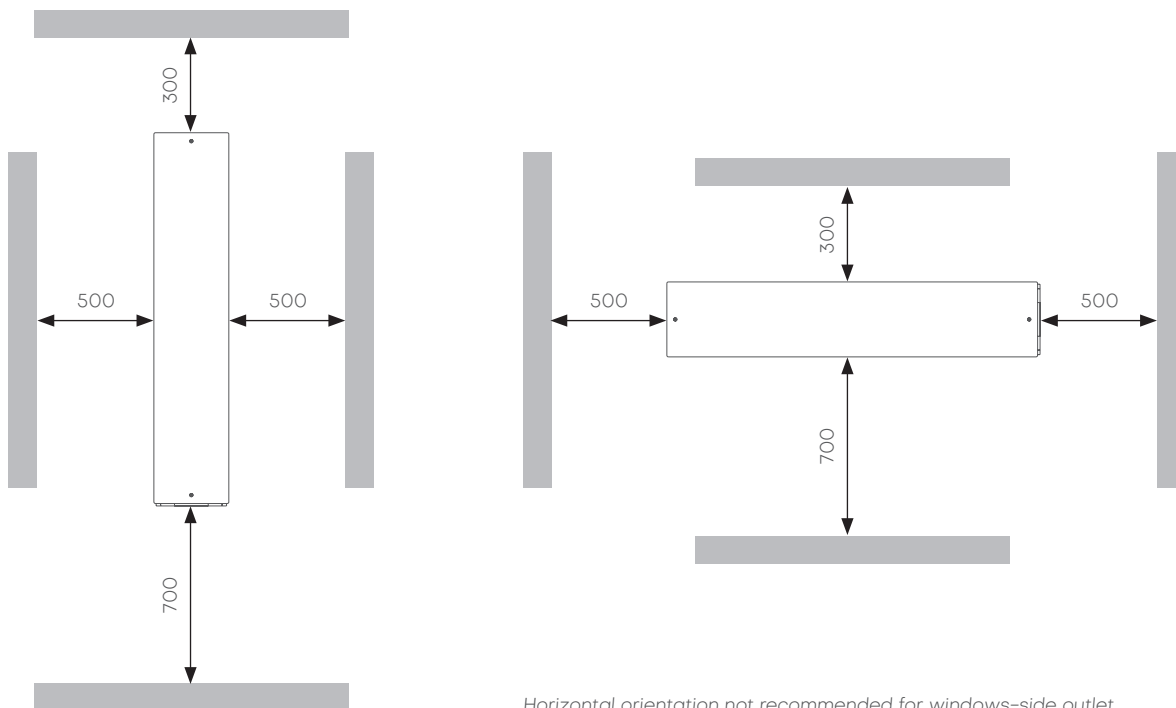

Horizontal orientation not recommended for windows-side outlet.

## Dimensional drawings

**Flow40**  
Facade output

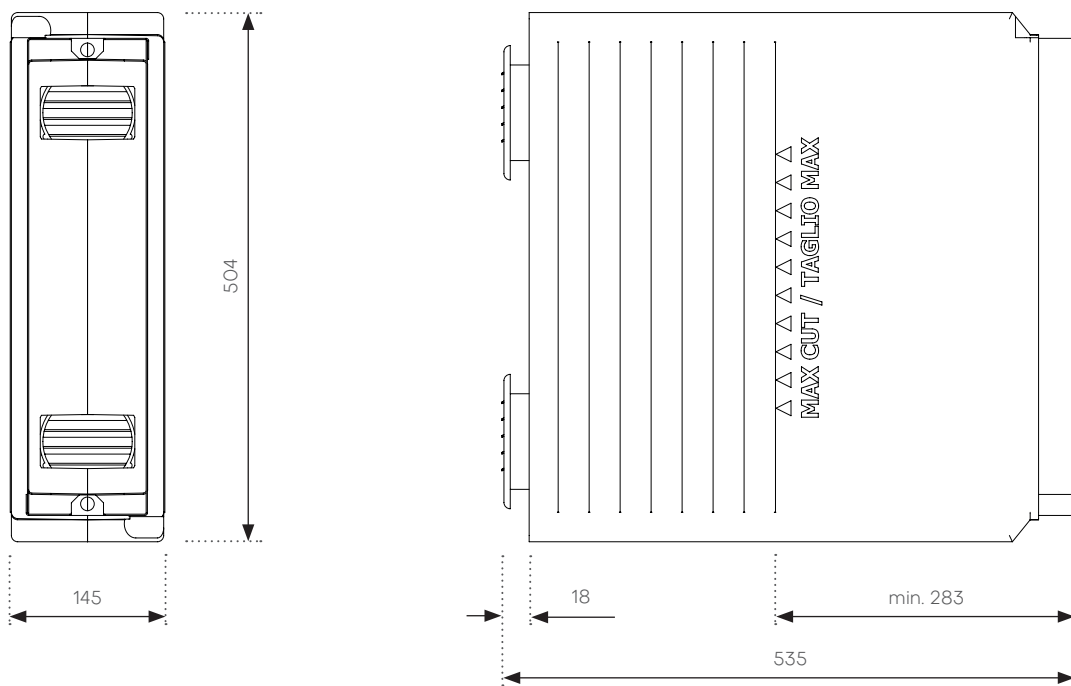

**Flow40**  
Window-side outlet

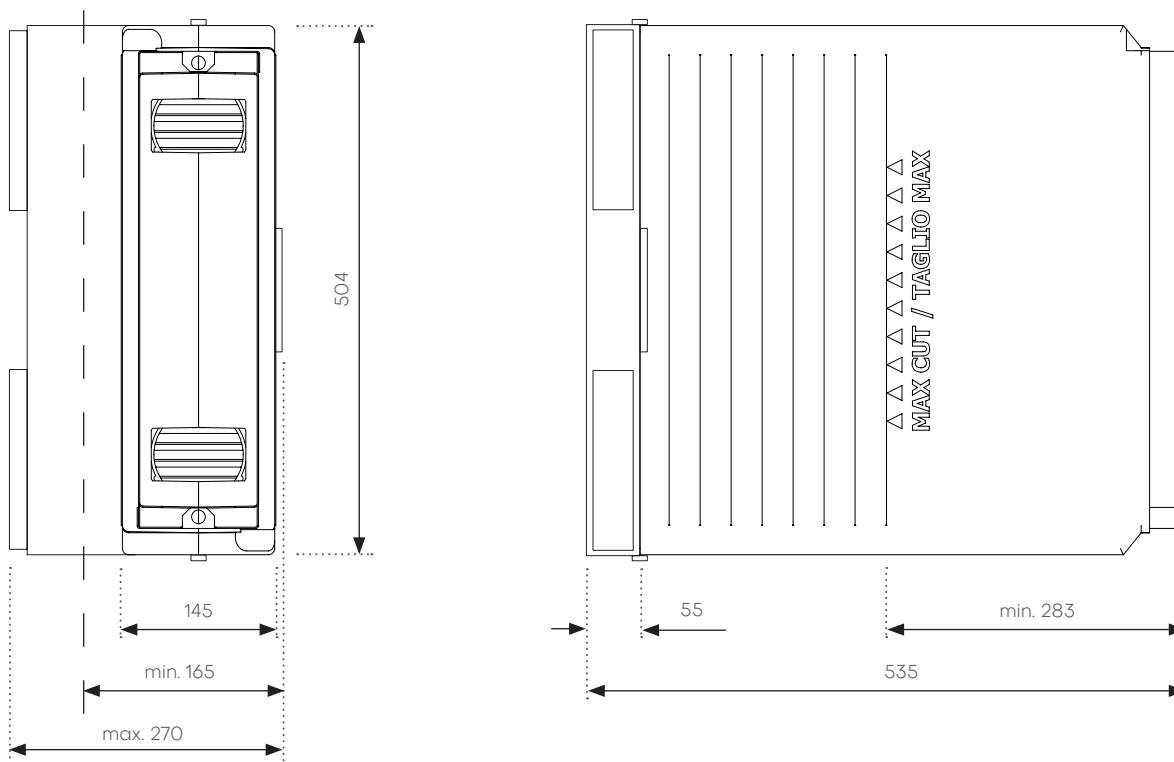

# New configurations

*Simple, modular, made-to-measure*

Helty introduces a **completely revamped configuration system** for Flow40, the flagship model of the range, enabling designers to **create the ideal solution for every construction site** by combining various elements in a modular way:

- // external grille outlet
- // heat exchanger type
- // cover
- // sensors
- // filter type
- // HRV unit control
- // with or without shutters
- // with or without shutters and preheating.

This new approach offers an unprecedented range of possibilities to meet every requirement: a **flexible approach** aimed at **simplifying design and reducing complexity on site**, allowing the system to be pre-installed during the building works and completed at a later stage by selecting the unit with all the necessary customisations.

## New features: shutters and preheating

The **shutters** activate automatically when the unit is switched off to prevent the entry of cold air. Ideal for installations above the 6th floor or in windy areas. **Preheating**, designed for northern and particularly harsh climates, extends operation down to -25 °C (enthalpy) or -10 °C (sensible).

## Flow40 configuration

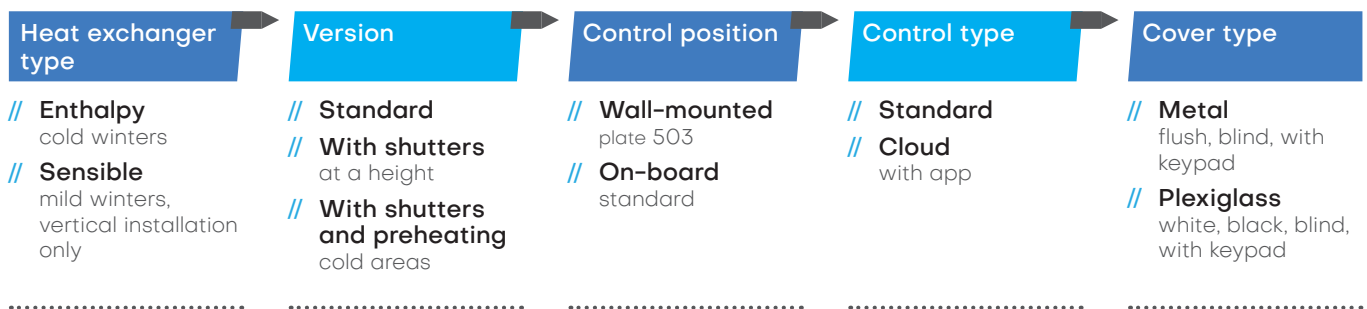

## New configurator for calculating airflows

To support the day-to-day work of designers and heating and ventilation engineers, **we have launched a new digital tool designed to simplify and speed up the sizing of decentralised heat recovery ventilation systems.** The configurator has been developed **in accordance with UNI EN 16798** and guides professionals step by step through the process of **determining ventilation airflow rates** based on basic design criteria (location, building class, ventilation class) and the details of individual rooms, in both residential and commercial settings. As well as **facilitating the calculation of air exchange requirements** determined in accordance with technical standards, the configurator **suggests Helty Flow decentralised solutions** and allows you to choose the most suitable ones for each room.



Size your system with the new configuration tool

## Experience and 3D Configurator

Would you like to learn more about the Helty Flow40 wall-recessed HRV and how it can be integrated into your project? Do you need to know in which positions it can be installed and which configurations are available for ventilation grilles? Do you want to know more about the features and maintenance it requires? Go to the site section and discover the new 3D configurator dedicated to Flow40: an interactive experience that allows a virtual tour of the solution and offers a specific focus on the installation, use and maintenance of the HRV system.



Scan the QR Code and go to the 3D configurator

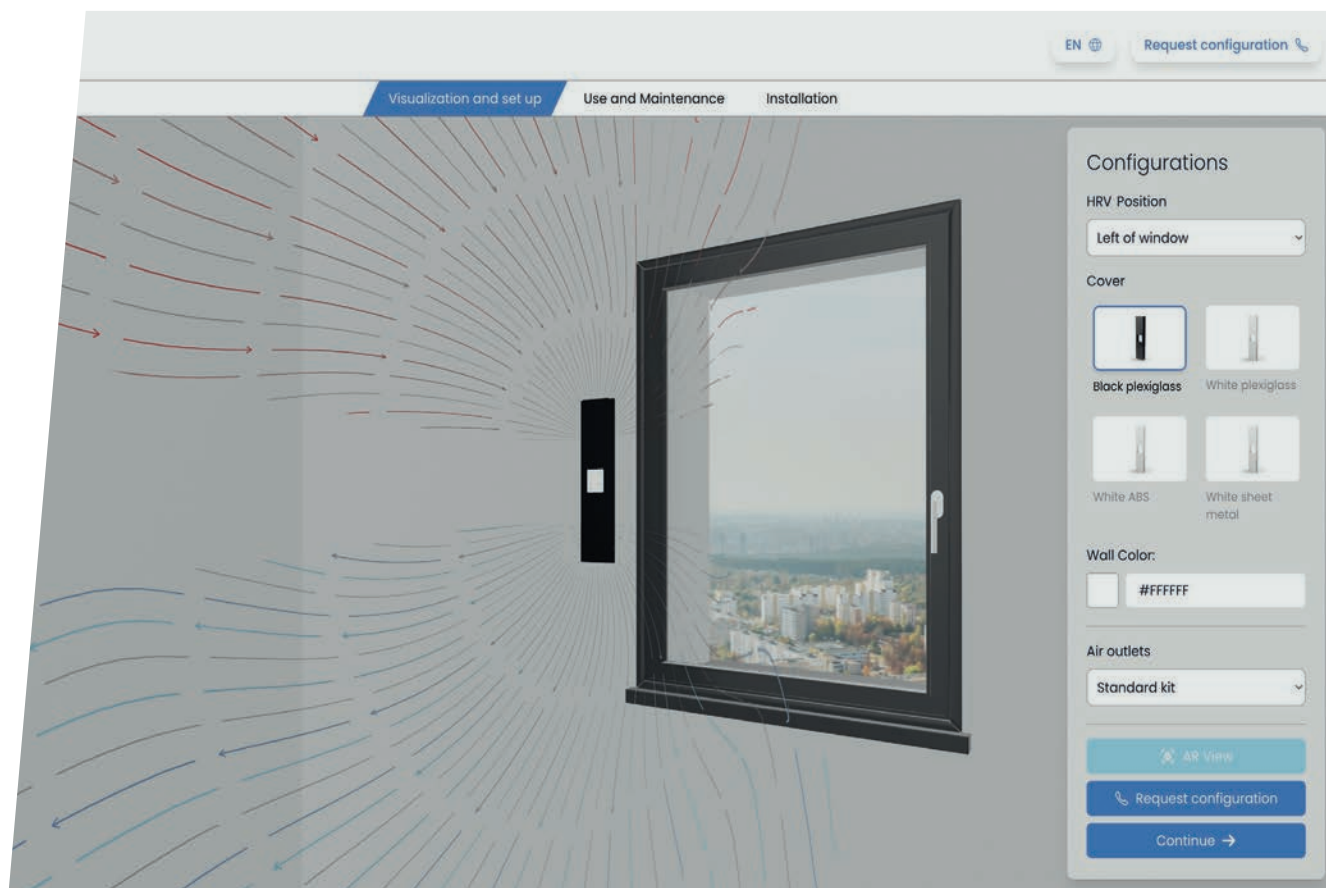



# Flow 120/120H/C120

Compact, silent, versatile,  
also available ducted

Flow120 is the perfect answer for everyday environments that require **more air exchange**, without sacrificing **quietness and comfort**. Versatile and high-performance, Flow120 can be adjusted to four airflow speeds, in addition to night and hyperventilation modes. **The range from 13 m<sup>3</sup>/h to 120 m<sup>3</sup>/h** means that it can meet the ventilation needs of modern residential living spaces or small offices. Easy to install, the HRV unit minimises footprint, with a width of just 16 cm and height of only 92 cm. Also available in **120H version** – for **horizontal installation**, such as underneath a window – Flow120 offers a choice of different covers

to blend perfectly into any location. The option with **window-side outlet grilles** enables even more invisible application, with no changes to the appearance of the facade. With installation only in the specific setup for later completion, the unit can be mounted in masonry just 34.5 cm thick. With a **sound power of less than 40 dB(A)** at the working airflow rate (60 m<sup>3</sup>/h), Flow120 is **remarkably quiet**. It is also efficient, offering a **heat recovery of 88%**. Being compatible with the Hely Home app, the unit can be controlled remotely directly from a smartphone.

## Flow C120: Hely's first ductable HRV

The **FlowC120** ductable model offers an even more versatile **HRV system design**, **servicing multiple rooms** within residential units. This version, with **ductable supply and exhaust airflows of up to 8 metres\***, allows separate control of air delivery and suction in installation areas, taking stale air from a bathroom and injecting fresh air into an adjacent room, such as a bedroom. A smart solution, ideal e.g. for three-room apartments, to reduce HRV system implementation costs and manage **air exchange over adjacent rooms with a single decentralised ventilation unit**.

\* for details on the dimensions of the ducting see the technical manual

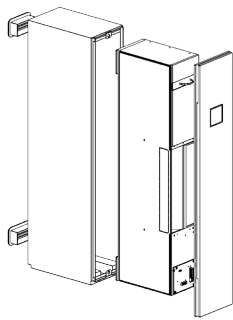

Flow120

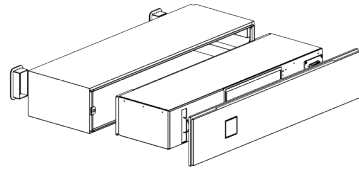

Flow120H

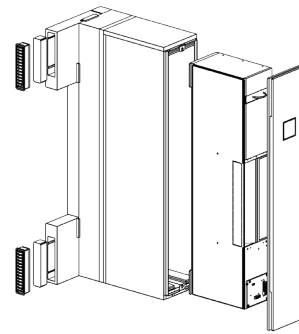

Flow120 windows-side outlet

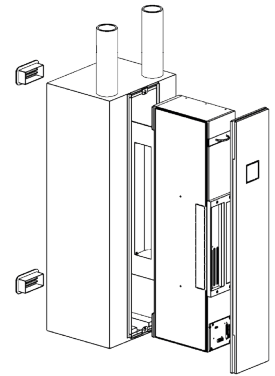

FlowC120



**88%**  
Heat recovery efficiency



**18.5** dB(A)  
Minimum sound pressure



**120** m<sup>3</sup>/h  
Maximum airflow



**ISO ePM2.5 65%**  
Intake air filtration



**-37.6** kWh/m<sup>2</sup>a  
SEC energy consumption (temperate climate)

Energy efficiency class **A**



## HRV unit technical data

Functions and features	UOM	Flw120	Flw120H	Flw©120
Heat exchanger		Enthalpy <sup>(1)</sup>	Enthalpy <sup>(1)</sup>	Enthalpy <sup>(1)</sup>
Night function		●	●	●
Hyperventilation		●	●	●
Filter replacement alert		●	●	●
Comfort function		●	●	●
Humidity sensor		●	●	●
External CO <sub>2</sub> /IAQ sensors <sup>(2)</sup>		compatible	compatible	compatible
Free-cooling / Free-heating		●	●	●
Remote control		option	option	option
Panel LED On/Off		●	●	●
Helty Home app <sup>(2)</sup>		option	option	option
Tested according to UNI EN 13141-8		●	●	●
Airflow rate	m <sup>3</sup> /h		13/30/45/60/80/120 <sup>(3)</sup>	
Flow adjustment			night + 4 stages + hyperventilation	
Power consumption	W		3/6/9/13/16.3/39 <sup>(3)</sup>	
Specific power input	W/m <sup>3</sup> /h	0.2/0.2/0.2/0.22/0.29/0.46 <sup>(3)</sup>	0.2/0.25/0.26/0.29/0.38/0.61 <sup>(3)</sup>	0.2/0.2/0.2/0.22/0.29/0.46 <sup>(3)</sup>
Supply voltage	V AC		230	
Operating voltage <sup>(4)</sup>	V DC		24	
Max. current consumption <sup>(5)</sup>	A		0.3	
Weight	kg		10	
HRV unit dimensions (W x H x D)	mm		160 x 920 x 286	
Preparation setup dimensions (W x H x D)	mm	190 x 990 x 335	190 x 990 x 335	390 x 990 x 335
Window-outlet preparation setup dimensions (W x H x D)	mm	319 x 1006 x 482	-	-
Installation orientation		vertical	horizontal	vertical
Heat recovery efficiency	%		88/82/75/72/68/57 <sup>(3)</sup>	
Bypass (free cooling/free heating)			electronic automatic	
Sound power <sup>(6)</sup>	dB(A)		30/31/35/40/47/54 <sup>(3)</sup>	
Sound pressure <sup>(7)</sup>	dB(A)		18.5/19.5/23.5/28.5/35.5/42.5 <sup>(3)</sup>	
Dn,e,W (facade noise abatement)	dB		45	
Intake filter <sup>(8)</sup>			ISO ePM2.5 65%	
Extraction filter <sup>(8)</sup>			ISO Coarse 90%	
Modbus RTU rs485			Yes <sup>(9)</sup>	
Reference climate			cold / temperate / warm	
Energy efficiency class (cold / temperate / hot)			A+ / A / E	
SEC (cold / temperate / warm)	kWh/m <sup>2</sup> a		-74.5 / -39 / -16.1	
Kit		card with QR-code digital manuals, power supply, control panel, connection cable, airtight gasket		
STD		1VMC02007	1VMC02014	1VMC02009

1. Counter-flow.

2. With Cloud Control Panel.

3. In hyperventilation mode.

4. The power supply unit provided enables operation with power supply of 230 V AC. To be connected during installation.

5. With 230 V AC supply voltage.

6. According to UNI EN ISO 3744.

7. Measured in a 30 m<sup>2</sup> semi-anechoic environment at a distance of 3 m.

8. UNI EN ISO 16890-1.

9. The control panel functions are lost.

## Accessories and spare parts

Article	Code
Cable coupler RJ10 + cable 5m	1VMCA9913
Reverse control panel cover adapter	1VMC99124
Grille adapter 120x60mm - Ø100mm x2	1VMC99058
White Bt Livingnow Adapter for Recessed Control Panel	1VMC99096
Black Bt Livingnow Adapter for Recessed Control Panel	1VMC99180
Adapter PG7 - 12mm	1VMC99129
Pipe adapter 120x60mm- Ø100mm x2	1VMC99115
Pipe adapter 120x60mm x2 Flow120H	1VMC99113
WiFi Hely air quality monitor <sup>(1)</sup>	4VMC00000903
WiFi Hely CO <sub>2</sub> monitor <sup>(1)</sup>	4VMC00000902
Flow120 sheet metal blind cover	1VMC99188
Flow120 PMMA white blind cover	1VMC99187
Flow120 PMMA black blind cover	1VMC99203
Flow120 sheet metal cover	1VMC99098
Flow120 PMMA white cover	1VMC99099
Flow120 PMMA black cover	1VMC99104
Filter Coarse 60% x10 Flow120	1VMC06014
Filter Coarse 60% x5 Flow120	1VMC06015
Filter ePM1 80% x10 Flow120	1VMC06019
Filter ePM1 80% x5 Flow120	1VMC06018
Filter ePM2.5 65% + Coarse60%x10 Flow120	1VMC06012
Filter ePM2.5 65% + Coarse60%x5 Flow120	1VMC06013
External grilles 120x60mm	1PVCVMC00009
Horizontal external grilles + hood 120x60mm	1VMC99128
Slim external grilles + mesh	1VMC00000237
Vertical external grilles + hood 120x60mm	1VMC99127
Insulation for Flow120 setup	1VMC99103
Cloud blue control panel + 800mm cable	1VMC99210
Flow120 Cloud blue blind control panel	1VMC99208
Cloud blue built-in control panel + 5m cable	1VMC99202
STD blue built-in control panel + 5m cable	1VMC99201
Cloud blue control black panel + 800mm cable	1VMC99244
STD blue control black panel + 1000mm cable	1VMC99242
STD blue control panel + 1000mm cable	1VMC99215
Flow120 protection panel	1VMC99116
Flow120 setup	1VMC03007
Flow120 setup for window-side	1VMC03009
FlowC120 setup	1VMC03008
60mm extension sheet metal panel	1VMC99069
Ceiling support Flow120 H	1VMC99114
Remote control	4VMC00000900
Pipe 120x60mm L 370mm x2	1VMC99054

1. Cloud Control Panel required.

.....

## Flow-head charts

- |                    |                                      |                  |                           |
|--------------------|--------------------------------------|------------------|---------------------------|
| <b>A</b> Head      | <b>1</b> Super-minimum speed (night) | <b>3</b> Speed 2 | <b>5</b> Speed 4          |
| <b>B</b> Flow rate | <b>2</b> Speed 1                     | <b>4</b> Speed 3 | <b>6</b> Hyperventilation |

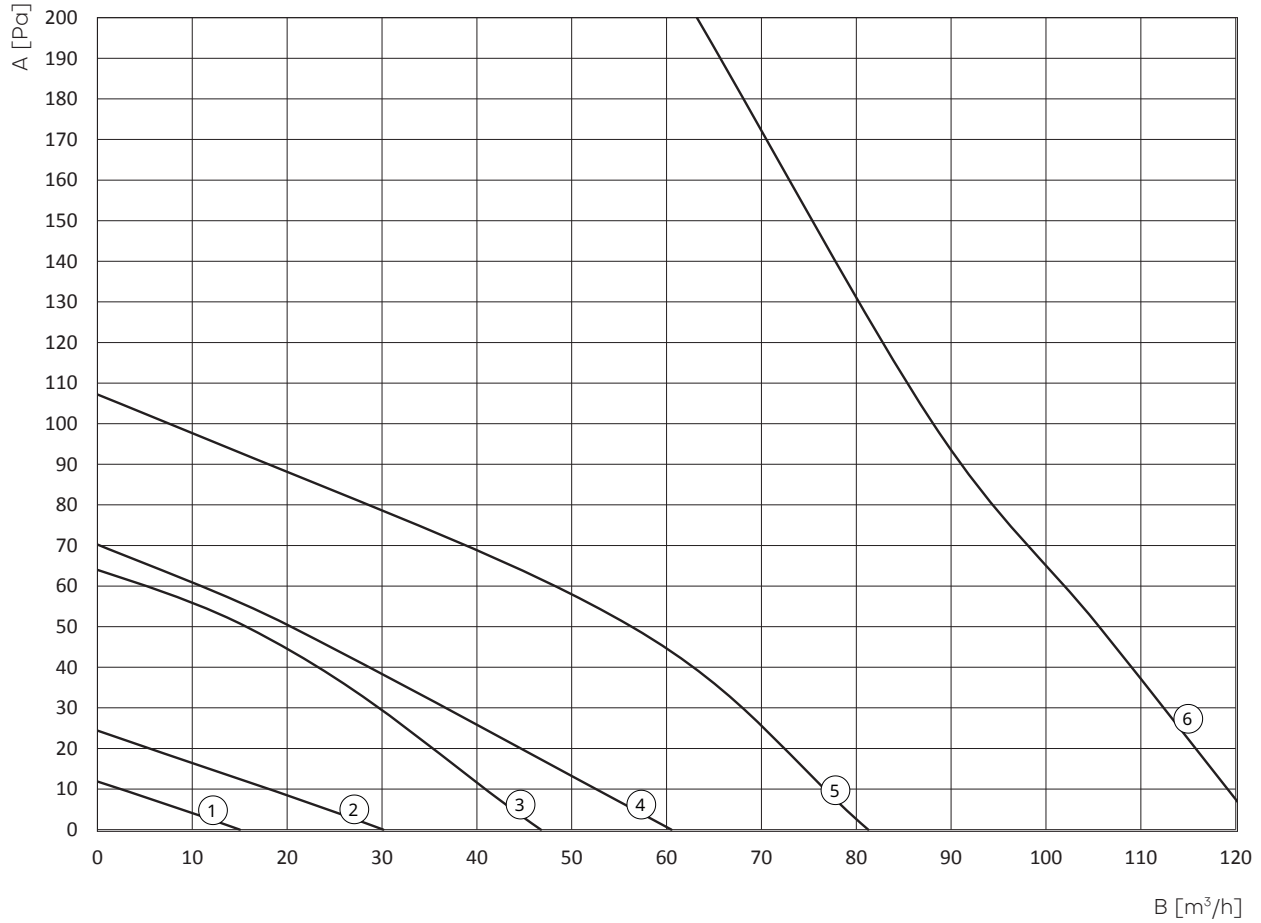

## Recommended buffer zones

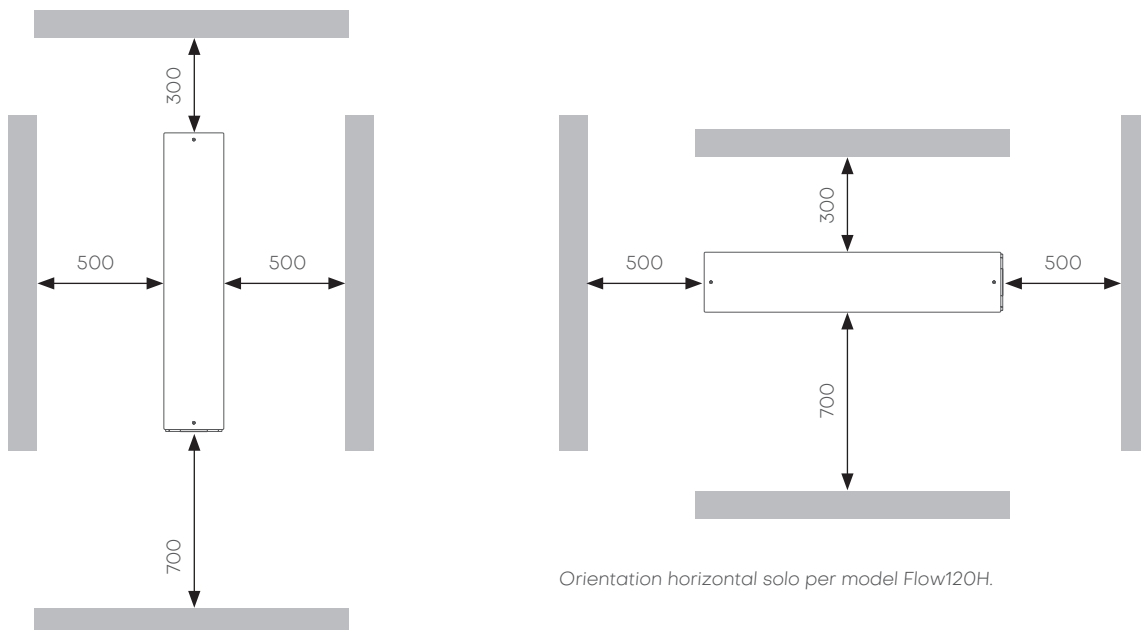

## Dimensional drawings

### Flow120/120H

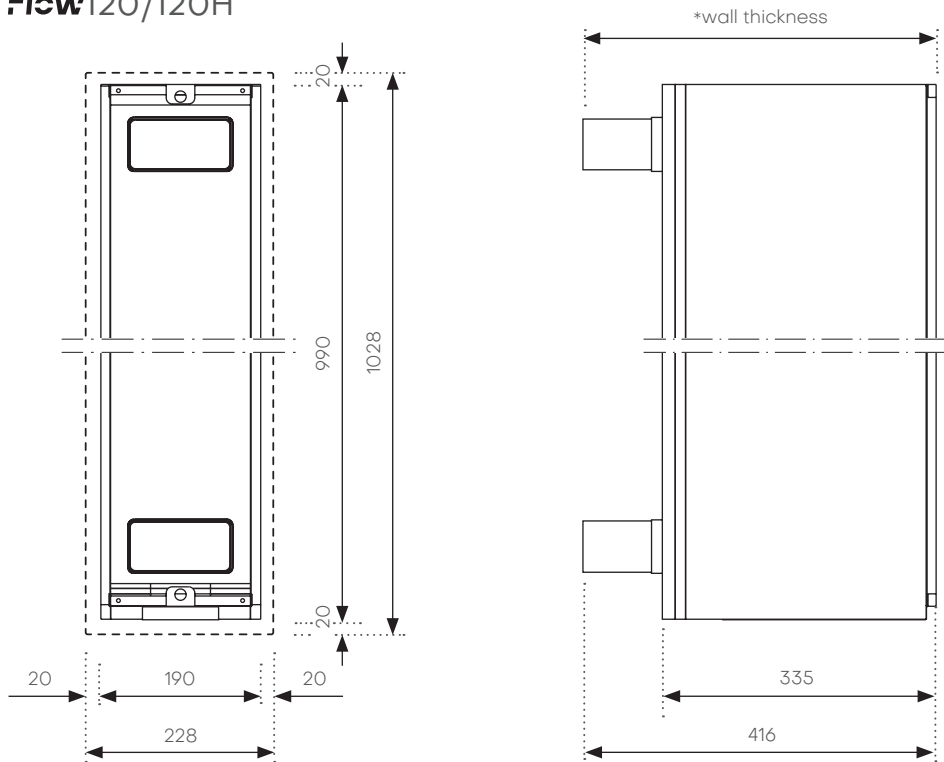

### FlowC120

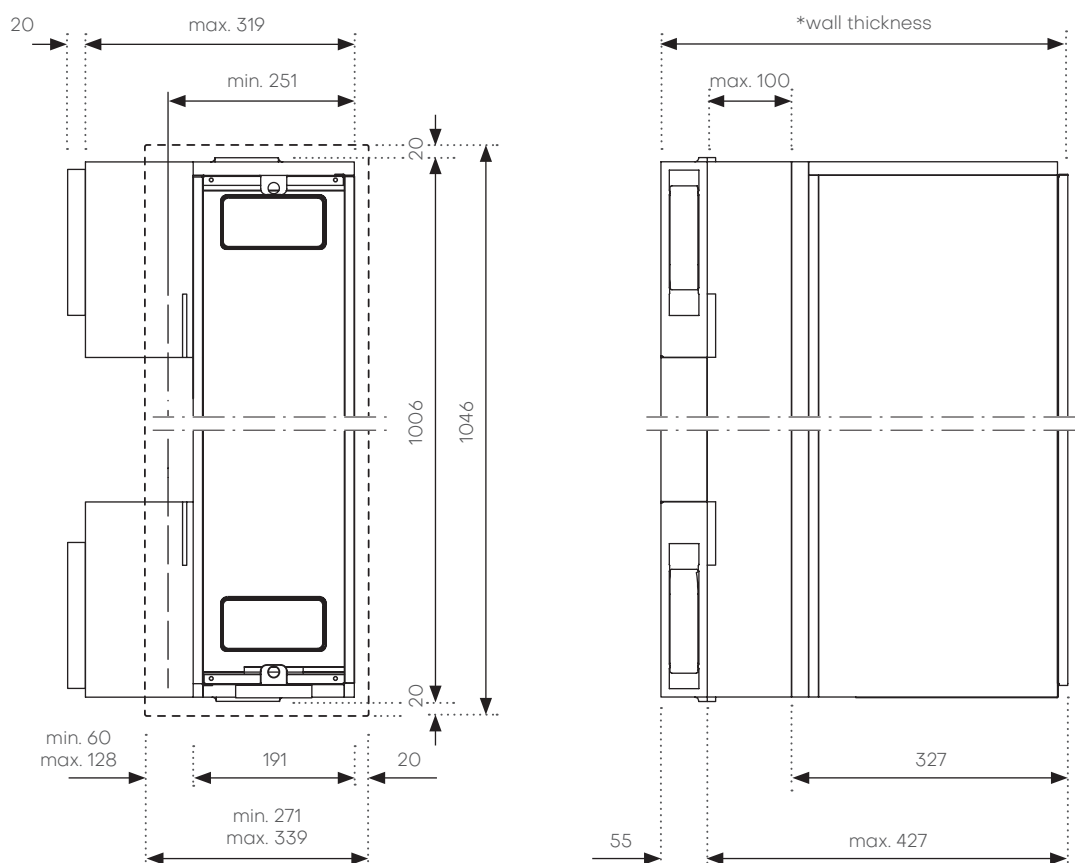

.....

## Dimensional drawings

### Flow120

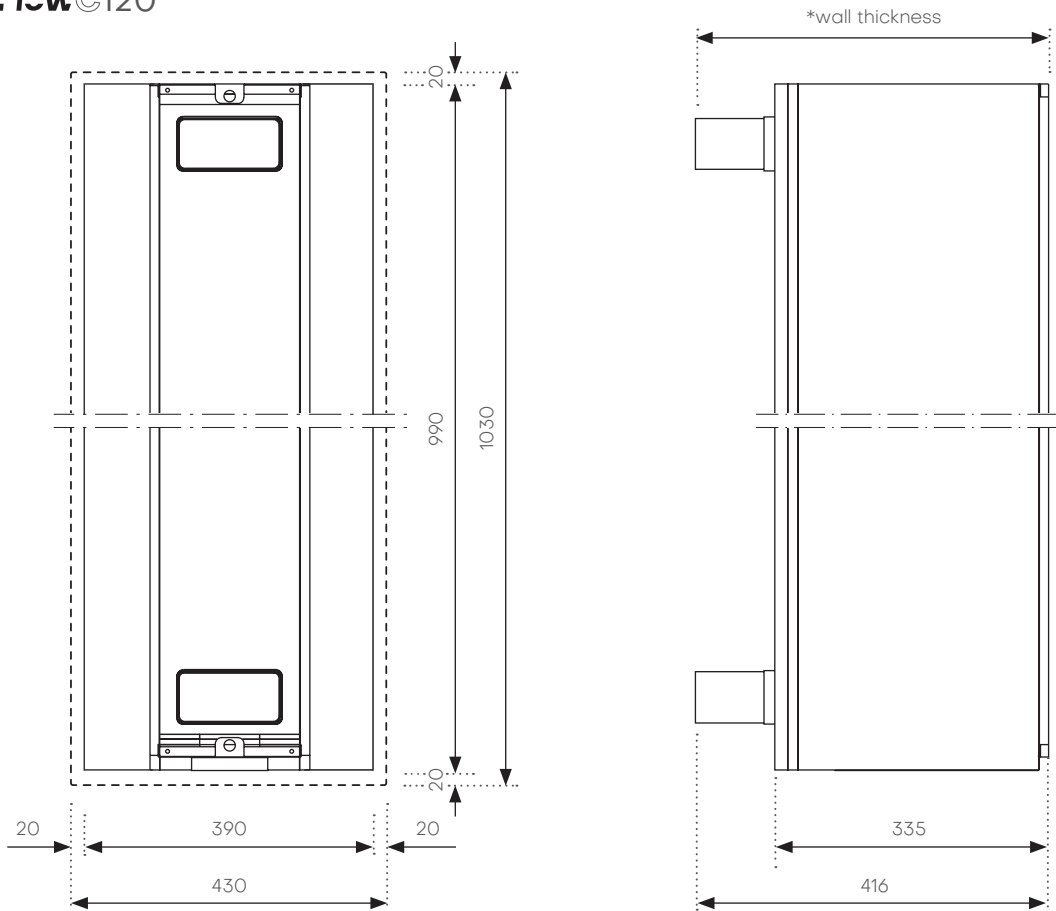

## Flow120 configuration options

Installation type	Control position	Control type	Cover type
<ul style="list-style-type: none"> <li>// Vertical</li> <li>// Horizontal</li> </ul>	<ul style="list-style-type: none"> <li>// Wall-mounted plate 503</li> <li>// On-board standard</li> </ul>	<ul style="list-style-type: none"> <li>// Standard</li> <li>// Cloud with app</li> </ul>	<ul style="list-style-type: none"> <li>// Metal blind, with keypad</li> <li>// Plexiglass white, black, blind, with keypad</li> </ul>

.....



Example diagram of an HRV system in a three-room flat managed with the FlowC120 ductable, wall-recessed system. Air supply and return can be partitioned off to other rooms adjacent to the one in which the recessed unit is installed.

.....

## Customisable cover to harmonise with any furnishing style

The Flow40 and Flow120 offer a new range of customisation options, with a choice of black or white plexiglass covers, or white pre-painted sheet metal covers, both either blind or with an integrated keypad, to blend seamlessly with the style of any room. The plexiglass variant has a convenient magnetic clip system for easy filter inspection and replacement.



A new flush-mounted cover is available exclusively for Flow40 for a design solution that allows the Helly HRV to blend in perfectly with any setting, without trade-offs.

## Wall-recessed HRV

The preparation for installing Hely Flow HRV units is a three-step process:

1. make a rectangular hole in the wall according to the shape required by the type of unit to be installed;
2. install the preparation setup in the wall, including external air vents, and seal the perimeter of the preparation with flexible polyurethane foam;
3. insert the HRV unit and connection to the power supply and position the inner cover.
4. Condensate drainage must be managed in versions with a sensible heat recovery unit.

See the instruction manual for more details.

The preparation setup can be purchased separately to be inserted into the masonry already at the construction site; it can also be completed later with the installation of the HRV unit and cover.

### Slim grille accessory



The Flow40 model with windows-side outlets can also be configured with 40x180mm slim external grilles (using an accessory kit).



.....

# HRV for energy upgrades

Patented HRV system installed in the exterior cladding, with no impact on the facade



Model	FlowMANHATTAN					
Version	LH STD	RH STD	LH Pure	RH Pure	LH Elite	RH Elite
Night function	●	●	●	●	●	●
Hyperventilation	●	●	●	●	●	●
Filter replacement alert	●	●	●	●	●	●
Humidity sensor	-	-	●	●	●	●
CO <sub>2</sub> and VOC sensor	-	-	-	-	●	●
Remote control	●	●	●	●	●	●
Control panel Removable STD	compatible	compatible	compatible	compatible	compatible	compatible
Control panel Removable cloud	compatible	compatible	compatible	compatible	compatible	compatible
Panel LED On/Off	●	●	●	●	●	●
Helty Home app <sup>(1)</sup>	compatible	compatible	compatible	compatible	compatible	compatible
<b>Code</b>	<b>1VMC05004</b>	<b>1VMC05000</b>	<b>1VMC05005</b>	<b>1VMC05002</b>	<b>1VMC05006</b>	<b>1VMC05003</b>

1. Included with remote Cloud Control Panel.

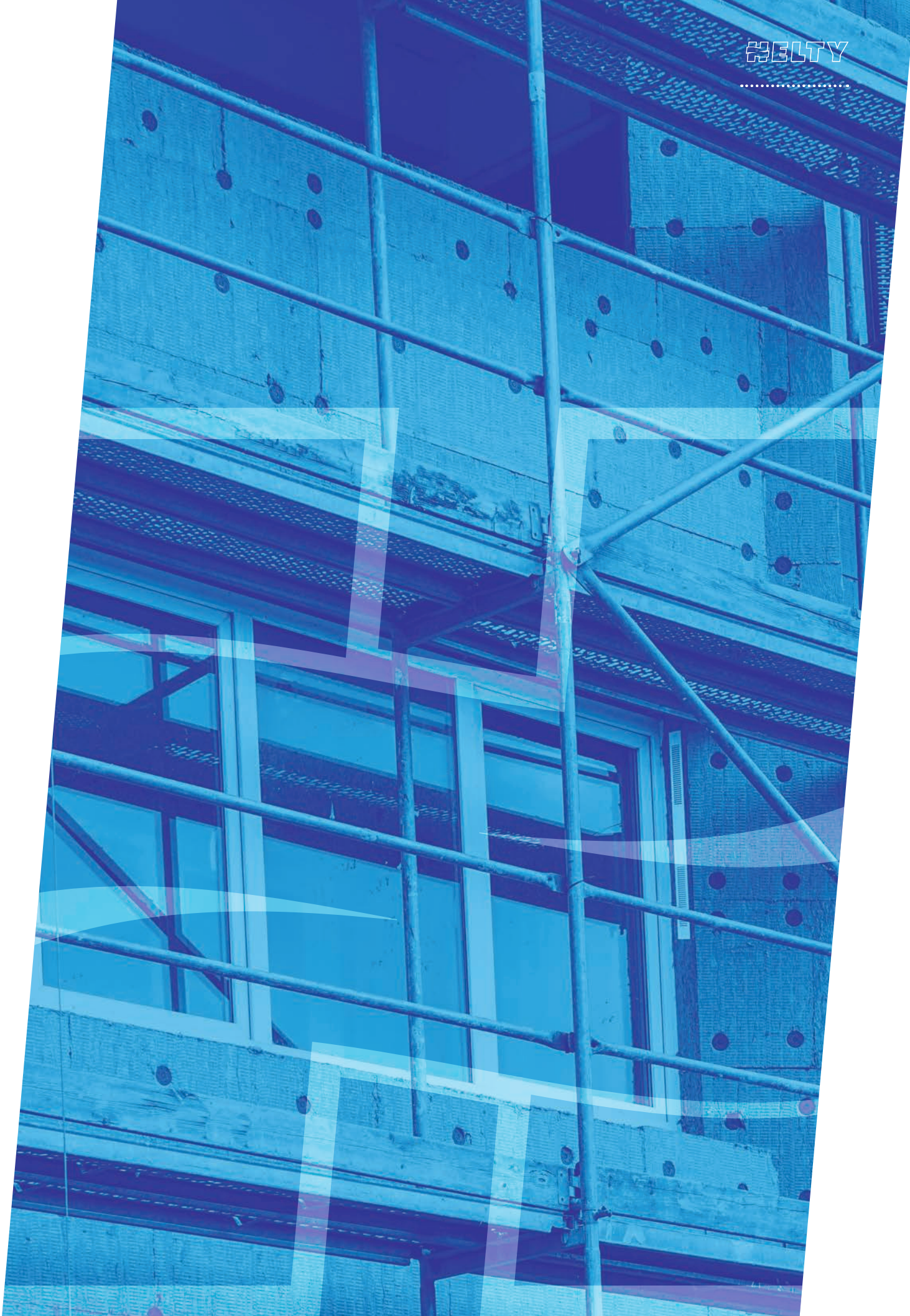

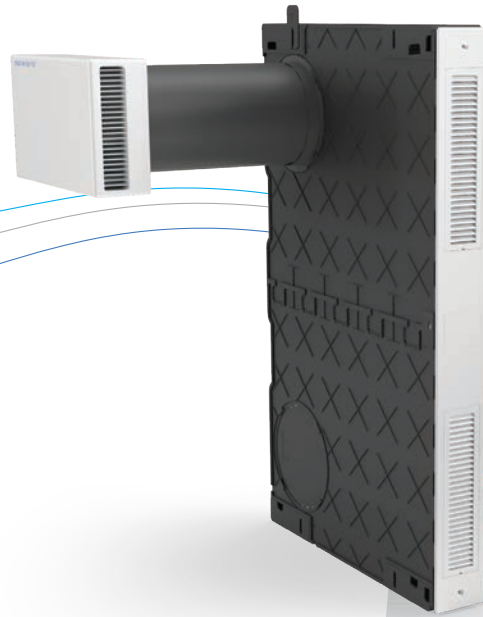

# Flow MANHATTAN<sup>®</sup>



*A revolutionary decentralised HRV installed "under the skin" in the exterior cladding*

**FlowMANHATTAN reinvents decentralised ventilation for individual rooms offering a solution to designers and builders in which the HRV unit is camouflaged in the external cladding layer.**

The airflow grilles, which are arranged on the side of the window, respect the architectural profile of the building **and avoid any impact on the facade. The internal impact is also minimal** with a particularly compact diffuser design. The intake and extraction airflows, separated by a special septum, pass through a **single 160-mm coring hole**. The formwork, which is fixed to the external masonry when the exterior cladding is installed, makes it possible

to prepare for **HRV system installation** and complete it at a later stage with the ventilation unit if required. The dual-flow HRV unit extracts stale air from the indoor environment and introduces **new, oxygenated and clean air through special ePM2.5 65% filters** as standard. Ventilation speeds are variable as required with **maximum airflow rate of 70 m<sup>3</sup>/h**. The enthalpy heat exchanger allows **recovery of up to 70% of the heat in the extracted air by pre-heating the fresh airflow.**



*Standard, Plus, Elite versions and control from the app*

The most equipped versions integrate a **hygrometric sensor, CO<sub>2</sub> and VOC sensors** on board the HRV unit to monitor indoor air quality parameters, as well as a removable control panel and the possibility of **remote control** via the **Helty Home app**. Also an ideal solution for the hospitality sector with Modbus connectivity and BMS (Building Management System) integrations.

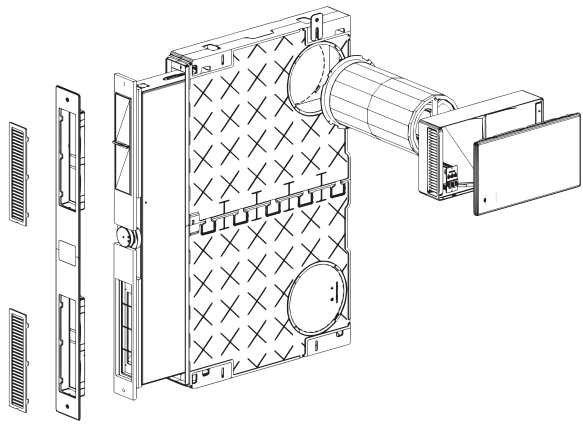

Sensors for automatic humidity, CO<sub>2</sub> and VOC management



Modbus RTU rs485 integration



Remote panel for controlling the unit and setting functions



**70%**

Heat recovery efficiency



**16.5** dB(A)

Minimum sound pressure



**70** m<sup>3</sup>/h

Maximum airflow



**ISO ePM2.5 65%**

Intake air filtration



**-35.4** kWh/m<sup>2</sup>a

SEC energy consumption (temperate climate)

Energy efficiency class **A**

Installation totally from the outside while installing the exterior cladding.

.....

A completely external solution, which has minimal impact on the design of the house and guarantees the highest levels of acoustic comfort

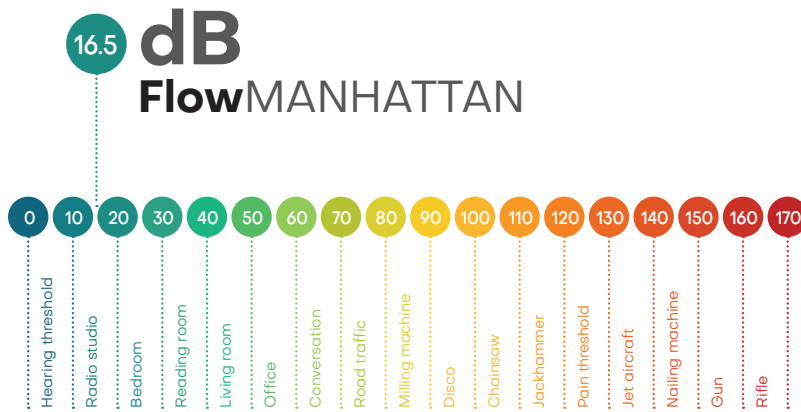

By placing the HRV unit in the outer edge of the masonry, inside the insulating cladding, Hely Flow MANHATTAN ensures a **sound performance that provides optimal acoustic comfort**, with a sound pressure of 16.5 dB at minimum speed.



Frame the QR Code and watch the video on FlowMANHATTAN

## Technical data

Functions and features	UOM	FlwMANHATTAN					
		LH STD	RH STD	Plus SX	Plus DX	LH Elite	RH Elite
Version							
Night function		●	●	●	●	●	●
Hyperventilation		●	●	●	●	●	●
Filter replacement alert		●	●	●	●	●	●
Humidity sensor		-	-	●	●	●	●
CO <sub>2</sub> and VOC sensor		-	-	-	-	●	●
Remote control		●	●	●	●	●	●
Control panel Removable STD		option	option	option	option	option	option
Control panel Removable cloud		option	option	option	option	option	option
Panel LED On/Off		●	●	●	●	●	●
Hely Home app <sup>(1)</sup>		option	option	option	option	option	option
Remote Control Panel		optional (compatible with 503 electrical box)					
Airflow rate	m <sup>3</sup> /h	20/25/30/40/50/70 <sup>(2)</sup>					
Flow adjustment		night + 4 stages + hyperventilation					
Power consumption	W	5/6/7/9.5/13/29 <sup>(2)</sup>					
Specific power input		0.25/0.24/0.23/0.24/0.26/0.49 <sup>(2)</sup>					
Supply voltage	V AC	230					
Operating voltage <sup>(3)</sup>	V DC	24					
Max. current consumption <sup>(4)</sup>	A	035					
Weight	kg	7					
HRV unit dimensions (W x H x D)	mm	460 x 740 x 65					
Preparation setup dimensions (W x H x D)	mm	512 x 826 x 88					
Internal diffuser dimensions (W x H x D)	mm	325 x 185 x 85					
Heat exchanger		enthalpy cross-flow					
Heat recovery efficiency	%	70/64/58/58/57/56 <sup>(2)</sup>					
Bypass (free cooling/free heating)		manual electronic					
Sound power <sup>(5)</sup>	dB(A)	28/31/36/43/48/56 <sup>(2)</sup>					
Sound pressure <sup>(6)</sup>	dB(A)	16.5/19.5/24.5/31.5/36.5/44.5 <sup>(2)</sup>					
Dn,e,W (facade noise abatement)	dB	51					
Intake filter <sup>(7)</sup>		ISO ePM2.5 65%					
Extraction filter <sup>(7)</sup>		ISO Coarse 60%					
Modbus RTU rs485		Yes <sup>(8)</sup>					
Reference climate		cold / temperate / warm					
Energy efficiency class (cold / temperate / hot)		A+ / A / E					
SEC (cold / temperate / warm)	kWh/m <sup>2</sup> a	-67.7/-35.4/-14.3					
Kit		installation manual, HRV filter, airtight gaskets, remote control with batteries					
Code		1VMC05004	1VMC05000	1VMC05005	1VMC05002	1VMC05006	1VMC05003

1. Including remote Cloud control panel.

2. In hyperventilation mode.

3. The power supply unit provided enables operation with power supply of 230 V AC. To be connected during installation.

4. With 230 V AC supply voltage.

5. According to UNI EN ISO 3744.

6. Measured in a 30 m<sup>2</sup> semi-anechoic environment at a distance of 3 m.

7. UNI EN ISO 16890-1.

8. The Cloud control panel functions are lost.

.....

## Accessories and spare parts

Article	Code
Cable coupler RJ10 + cable 5m	1VMCA9913
White Bt Livingnow Adapter for Recessed Control Panel	1VMC99096
Black Bt Livingnow Adapter for Recessed Control Panel	1VMC99180
WiFi Helyt air quality monitor <sup>(1)</sup>	4VMC00000903
WiFi Helyt CO <sub>2</sub> monitor <sup>(1)</sup>	4VMC00000902
FlowMANHATTAN external cover	1VMC06002
Internal diffuser FlowMANHATTAN	1VMC06005
Empty internal diffuser	1VMC06004
FlowMANHATTAN template	1VMC06001
Filter ePM2.5 65% + Coarse60%x10	1VMC06009
Filter ePM2.5 65% + Coarse60%x30	1VMC06010
Cloud built-in control panel + 5m cable	1VMC06011
STD built-in control panel + 5m cable	1VMC06006
FlowMANHATTAN setup	1VMC06000
Ø160mm internal hole cover rosette	1VMC06003
Remote control	4VMC00000900
Pipe + 150mm	1VMC06007

1. Cloud Control Panel required.

## Dimensional drawings

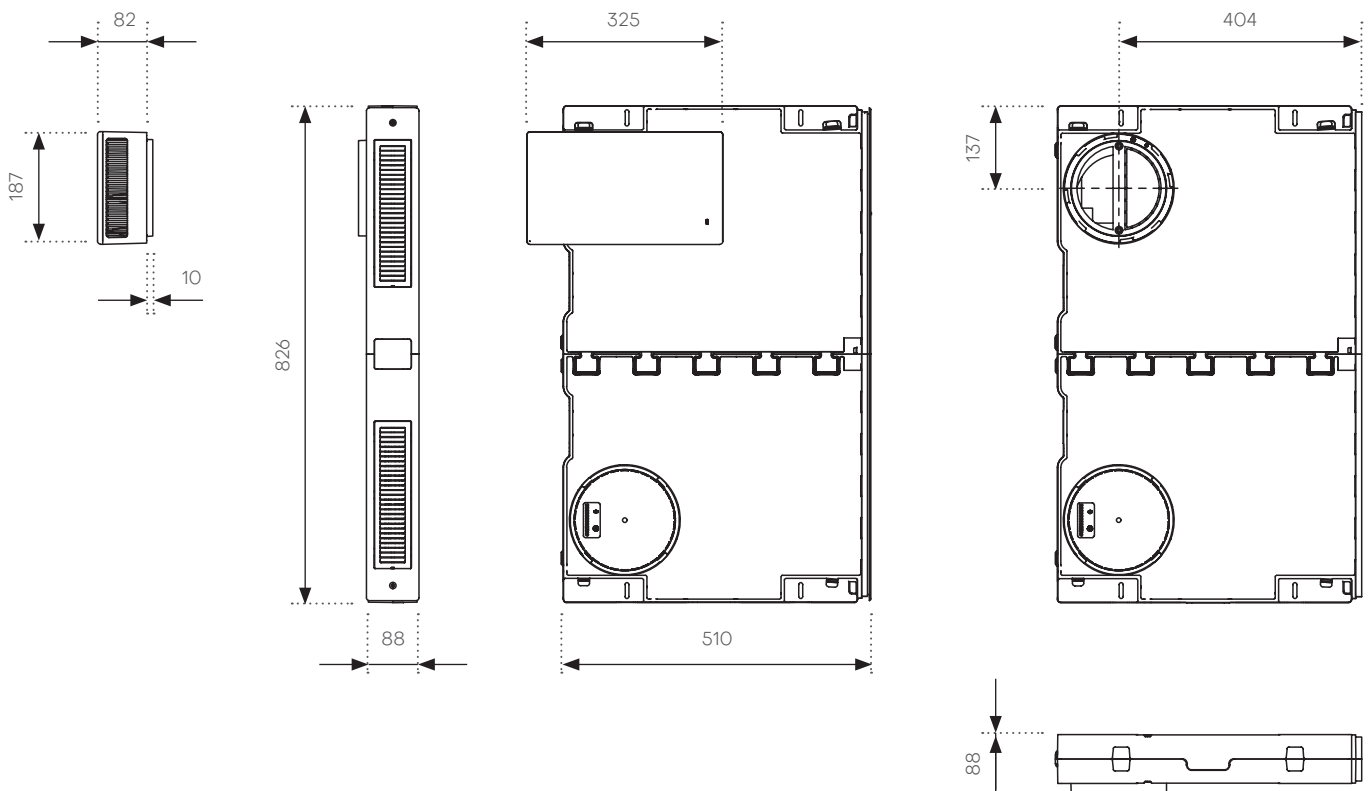



# IAQ sensors Indoor Air Quality

Intelligent technology for  
indoor air quality monitoring

Comprehensive, customisable air quality control without compromise: this is what the new **range of Helty sensors** do. Designed to **detect and monitor the main pollutants present in the home and work environments**, Helty IAQ Sensors are easy to install and use. They allow **constant monitoring of the main air quality parameters**, helping to improve the health, comfort and productivity of the people who live or work in enclosed spaces.

The line consists of devices that meet different needs:



CO<sub>2</sub> monitor

For specific control of **humidity, internal temperature and carbon dioxide parameters**.



IAQ monitor

Indispensable for comprehensive IAQ monitoring, it includes – in addition to CO<sub>2</sub> sensor parameters – the **detection of PM1/2.5/10 particulates**, and specific levels of **TVOC and formaldehyde pollutants**.



Radon monitor

Designed for accurate monitoring of **radon gas concentration levels** in a confined environment\*.

\* It is always advisable to consult a technician specialising in radon gas mitigation when planning the installation.



## Data and insight always within reach of the app

Compatible with all HRV units equipped with a cloud panel, Hely IAQ sensors integrate perfectly with heat recovery ventilation systems, facilitating optimal management of indoor air quality. With the **Hely Home app**, it is also possible to **monitor the detected parameters in real time, set customised scenarios** and program automatism based on user-defined intervention thresholds. It is an indispensable tool for anyone wishing to improve the quality of life in the home or office, offering advanced support for controlling pollutants and creating a healthy and comfortable environment.

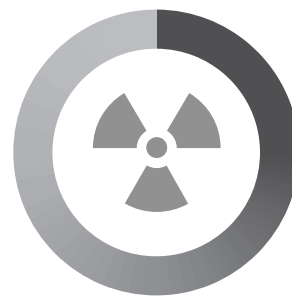

# Controls

*Many control options, maximum ease of use*

Helty HRVs are designed for maximum ease of use, thanks to a simple user interface and many control options. The **control panel** integrated into the cover can be used to manage all the main functions – ventilation speed, night mode, hyperventilation and free-cooling – with a single press\*. For those who prefer a control panel separate from the unit, the **Cloud control panel** (optional, to be fitted on the 503 electrical box) offers the same ease of use in a discreet, stylish design, ideal for any room. With the Cloud panel, you can also enjoy "full remote" control of the units via the **Helty Home mobile app**. Finally, the **infrared remote control** – fitted as standard on the wall-mounted HRV range and available as an option on other models – offers the freedom to control the unit remotely, without having to go near the appliance. Three solutions designed to suit every need and lifestyle, so that indoor air quality is always under control, without ever compromising on comfort.



\* Some functions are not available on the simplified control panel of FlowEASY and Flow30.

## Functions



### Filter alarm reset\*\*

This can be used to reset the filter replacement alarm after filters have been replaced, switching off the corresponding indicator LED.



### Ventilation adjustment

It allows the four different air exchange speeds to be set according to the ventilation needs of the room.



### Night function

This sets the HRV to a minimum ventilation speed and reduces the intensity of the LEDs to have a continuous and silent air exchange ensuring quality sleep. With a long press, the LEDs can be switched off completely.



### Hyperventilation

This increases the airflow rate to the maximum so as to achieve faster air exchange and ventilate a room for short periods at maximum performance.



### Free Cooling / Free Heating

Intelligent technology that allows natural cooling of the indoor environment. If the external air has a lower temperature than the inside air, the HRV system cuts off the heat recovery function before feeding the air into the environment to maintain the best thermal condition. This introduces naturally fresh air into indoor spaces for natural air conditioning. This technology is especially useful in the summer and mid-season at night, when the outdoor temperature is more comfortable. On the contrary, Free Heating allows, in mid-season or on warm winter days, to make use of the warmer external air.



### Filter replacement alarm

It warns when it is time to replace the filter to safeguard the performance of the unit.



### Comfort function\*\*

Detects indoor and outdoor temperatures, compares the measured values and, if there is a significant difference, automatically adjusts the ventilation speed to optimise heat recovery.

\*\* This function cannot be activated using the infrared remote control

# Helty Home app

*HRV management has never been so smart!*



**Helty Home** is the new **mobile app that enables simple and user-friendly management of HRV units directly from a smartphone or tablet.** Designed to allow the user to **control** heat recovery ventilation systems **remotely and integrally**, Helty Home offers the possibility of differentiating air exchange on the individual unit and on the individual home environment for maximum comfort at a single touch. The refreshed graphical user interface makes using the Helty Home app even smarter, with user-friendly layouts that put all information at your fingertips.

The application can be combined with a range of optional sensors for uncompromising indoor health in addition to monitoring humidity, temperature and indoor air quality parameters. The special Radon function, for compatible HRV models, can **monitor radon gas concentrations in rooms.** In combination with the optional sensors, Helty Home becomes an indispensable tool for effectively managing ventilation units with internal intelligence that automatically manages the airflow rate to dilute the presence of the pollutant and effectively mitigate the risk.

## Helty app download

The Helty Home app is available on the Apple Store for the IOS operating system and on the Google Play Store for the Android operating system.



It allows the operation of HRVs to be controlled and set remotely.



This indicates air quality data: humidity, temperature, VOC and CO<sub>2</sub>, Radon (in combination with optional external sensors).



It also allows all HRVs to be controlled simultaneously.

## Highlights and functions

- // Ventilation control
- // Environmental parameter monitoring (humidity, temperature, particulates, VOC, CO<sub>2</sub>)
- // Scenario programming with schedule and intervention thresholds
- // Remote control of several units simultaneously
- // Alerts through alerts

# Filters and spare parts

*Helty Flow ductless systems make changing the filter a breeze*

The user simply needs to **replace the air filter**, appropriately indicated by the LED on the unit or the app and **reset the filter alarm**.

For all wall-mounted, wall-recessed and upgrade HRV systems, this operation, which is needed on average after 6–8 months, can be managed independently by the user and takes just a few minutes. The filter alarm must be reset after changing the filters.



.....

# ESG: well-being and sustainable development

Choosing Helyt means choosing a technology that not only improves living comfort and facilitates energy savings, but has been created with a minimal ecological footprint, **for a sense of well-being that looks to future generations**. The quality of the air we breathe is inextricably linked to the **health of the planet** we inhabit. For Helyt, sustainability is not merely an abstract concept, but rather a strategic lever that guides every decision. As part of the Alpac Group, we have embarked on a **path of responsible evolution that integrates ESG (Environmental, Social, Governance) criteria** at the heart of our business model. We want to build a sustainable future that **combines technological innovation with a deep respect for the environment and a focus on people**.

## A real, measurable commitment

Through the publication of our **Sustainability Report**, we make our commitment to reducing our environmental impact and ensuring transparent governance processes visible and measurable, working to generate lasting value not only for our customers but for the entire community. We adopt a rigorous **eco-design** approach, prioritising the use of certified, recycled and recyclable raw materials. We monitor greenhouse gas (GHG) emissions to optimise production processes and **reduce energy waste**. **The well-being of our employees** is at the heart of our corporate strategy: we promote safe, inclusive and stimulating work environments, where professional growth and **gender equality** are absolute priorities. This ethical commitment also extends externally, through the careful selection of partners. We collaborate with a **responsible supply chain**, prioritising suppliers who share our ESG values.

Find out more





# HELTY®

Pure air for your home

# Healthy breathing in every room



#healthybreathing



4MKTO00006635