

HELTY®

Pure air for your home



Made in Italy



Indoor comfort and HRV systems

Catalogue 2023

July 2023

Healthy breathing in every room

A healthy life is inextricably linked to what we breathe. Air is the first and most important nourishment for all life forms. On average, a person breathes more than 12,000 litres of air a day.

Choosing to breathe healthy air, because it is constantly replenished and purified, is essential.

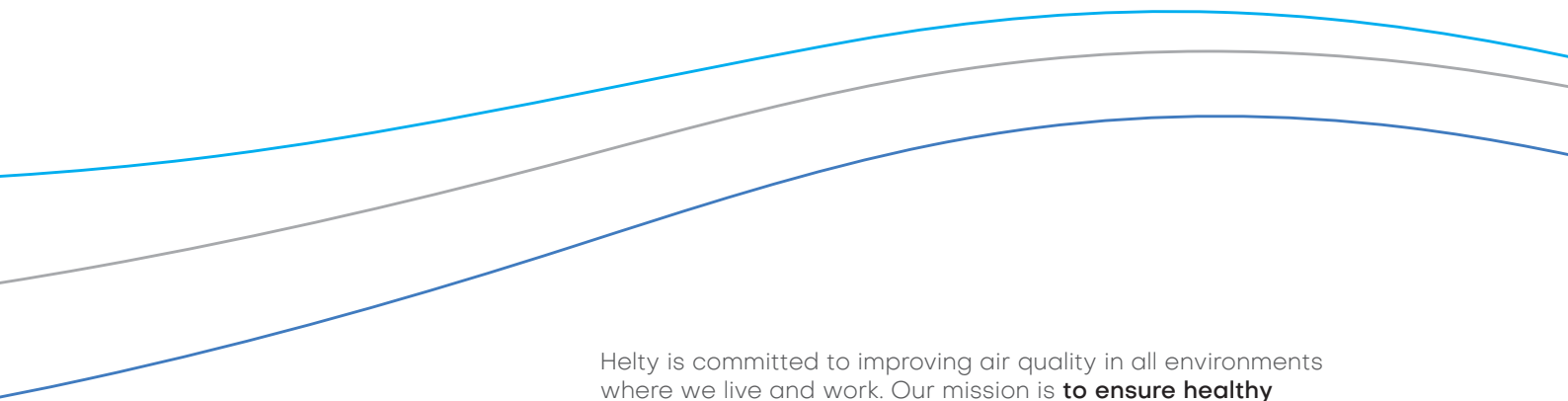

Helty is committed to improving air quality in all environments where we live and work. Our mission is **to ensure healthy clean air in every room – in homes, offices, classrooms and public places.**

We do this by offering those who design and install systems a range of innovative **Controlled Mechanical Ventilation solutions:** decentralised systems with dual continuous flow, carefully designed and easy to install, energy efficient and with proven effectiveness in reducing pollutants.

We make indoor areas, where people spend most of their time, healthier, more liveable and more comfortable.



The future of comfort is already here

The ongoing trends on the **decarbonisation** of buildings and the **energy requalification** of existing ones, combined with the new requirements that have emerged with the COVID pandemic, open up new scenarios for the **integration of building and HVAC systems**.

Buildings today require technologies that can simultaneously satisfy the needs for thermal comfort and indoor air healthiness

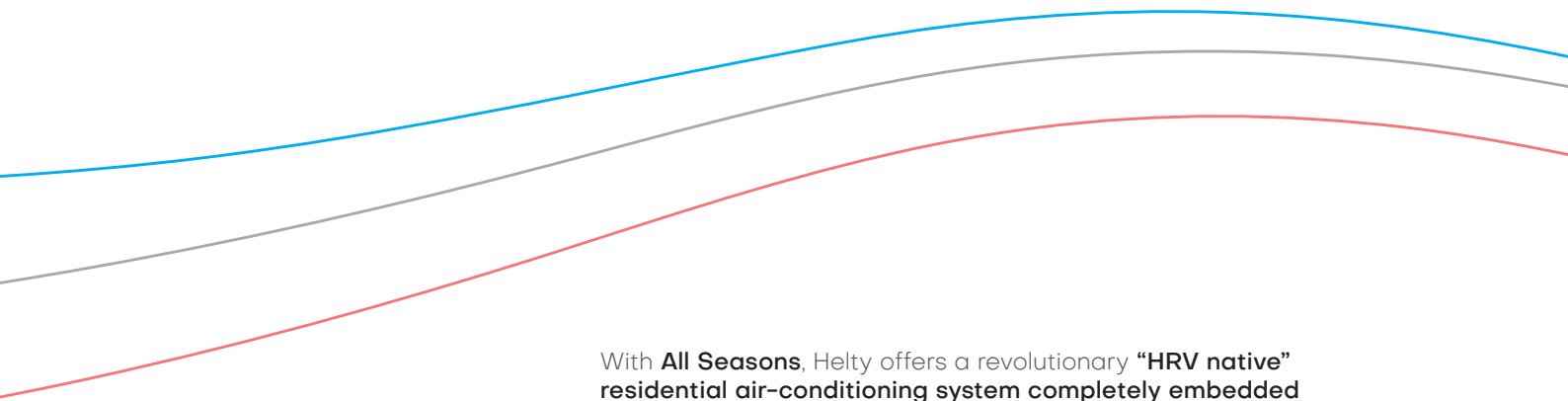

With **All Seasons**, Hely offers a revolutionary “HRV native” residential air-conditioning system completely embedded in the masonry, designed for “room-to-room” comfort management in an intelligent, efficient and independent way.

An unrivalled solution that offers all the benefits of split conditioning with air-to-air heat pump combined with continuous renewal and indoor air purification.

All Seasons is the new decentralised all-in-one solution for hot/cold and air replenishment, with a totally wall recessed design

Air conditioning modernises by blending seamlessly into the building envelope. A revolutionary solution for air conditioning and maximising well-being in every single environment, without affecting on architecture and interior design.





Contents

	Who is Helty?	8
	The Alpac Group	9
	Case history	10
	KlimaHaus Quality Seal	12
	BioSafe Validation	13
	ErP Directive Compliance	14
	Focus: Indoor air quality	16
	How Helty Flow works	18
	Flow range	20
	Wall-mounted HRV	22
New	Wall-mounted HRV - FlowULTRA	36
	Focus: HRV point-wise solutions compared	42
New	Wall recessed HRV	44
	Focus: Comparative analysis of HRV systems	54
	FlowMANHATTAN HRV for external wall insulation	60
New	Community HRV	66
	Focus: HRV and risk reduction in indoor environments	76
	HCloud	78
	Control panel	80
	Air Guard App	82
	Filters and spare parts	83
	Point-wise HRV: design advice	84
New	All Seasons Range	86
	All Seasons with window-side and facade output	88
	Control panel	93
	Focus: access to incentives	95
	Useful resources	100
	The Helty guides	100
	Environment	102

© Helty

Since Helty adopts a continuous product improvement policy, it reserves the right to modify its design, specifications and data shown in this catalogue without prior notice. Images are not contractually binding.

Who is Helty?

Decentralised HRV, focus on healthiness and energy saving

Helty is the Alpac Group company specialised in **decentralised solutions for Controlled Mechanical Ventilation**. We work side by side with heating technicians, planners and system installers, wholesalers of plumbing and heating materials, energy consultants and building healthiness experts to **spread the culture of healthy air in living and working environments**. We deal exclusively with Heat Recovery Ventilation (HRV) systems with superior air filtration and heat recovery: a **technology that is mandatory** in highly

energy-efficient buildings and necessary in the field of renovation to **prevent building-related ailments, increase building value and safeguard people's comfort and health**.

The **HRV solutions developed and produced by Helty entirely in Italy** are exclusively of the **dual continuous flow type**: they enable the indoor air to be constantly renewed in a balanced manner and with variable flows, purifying it of pollutants, pollen and particulates.

Certifications and partnerships

Not only comfort improves in homes integrating Helty ventilation, but also energy efficiency. The special enthalpy heat recovery system ensures **91% heat recovery performance certified by TÜV**. The performance of Helty ventilation systems is recognised by the **KlimaHaus HRV Quality Seal and validated by BioSafe**. Helty is a member of **AiCARR, CTI Italian Thermotechnical Committee, ANGAISA, AIAS**.





ALPAC®



The Alpac Group: technology for advanced construction

In the world of construction and design, the Alpac Group has always been synonymous with quality, research and innovation. In **over 40 years of activity**, we have built, brick by brick, a solid well-structured company capable of continuously expanding its horizons and responding proactively to the needs of any construction site.

We have taken part in several major challenges -- such as the **CityLife project in Milan** -- born out of collaborations with

companies and professionals who have chosen us because we have demonstrated our ability to provide high-performance technologies, custom-designed for every situation. Experiences that required commitment, courage, willpower to think outside the box and expand the field of action from time to time. Thanks to our well-defined organisational structure and our cutting-edge technological proposal, we can manage complex construction sites in

a timely manner, supplying all the required documentation and progress reports in line with other construction site operators.

Case history

CityLife Libeskind Residences

Milan, architect
Daniel Libeskind



Former "Nardari College" building

Treviso, Archi-Plan Studio,
renovation and energy
requalification of an early
20th century building in the
historic centre

Balduina 142

Rome, RDP Costruzioni,
Studio Marzullo, Socip,
Class A residential complex





Viganello
High School

Off-site construction
in Lugano (Switzerland)

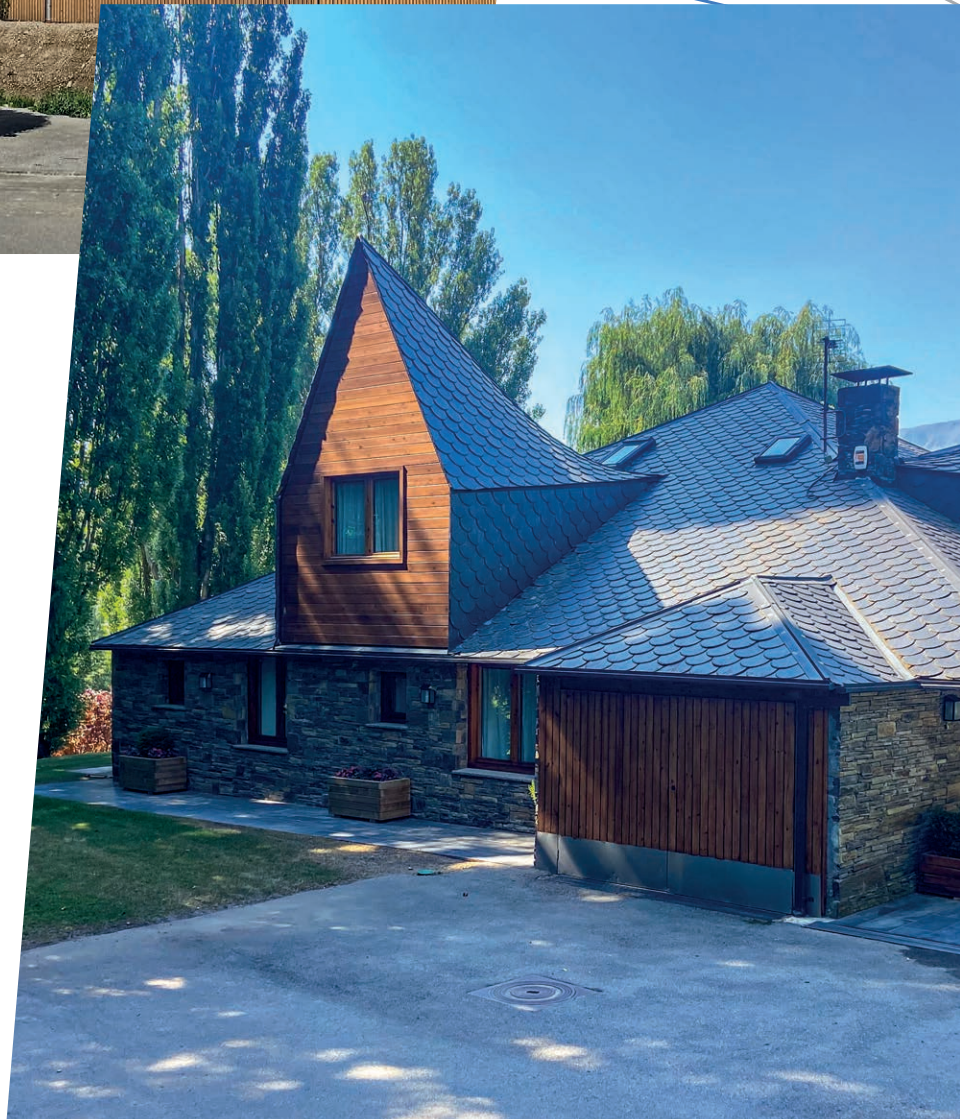

Residential Villa

Girona (Spain)

KlimaHaus Quality Seal

Guarantee of Quality
for clients and designers

Helty's FlowEASY/PLUS/ELITE, Flow40/100 ventilation systems have been awarded the Product Quality mark by the **KlimaHaus Agency in Bolzano**.

The KlimaHaus Product Quality Seals are intended to **transparently assess and inform clients and designers about the best solutions on the market** and represent a reliable and authoritative certification in the building sector, granted only to building products that meet high quality criteria.

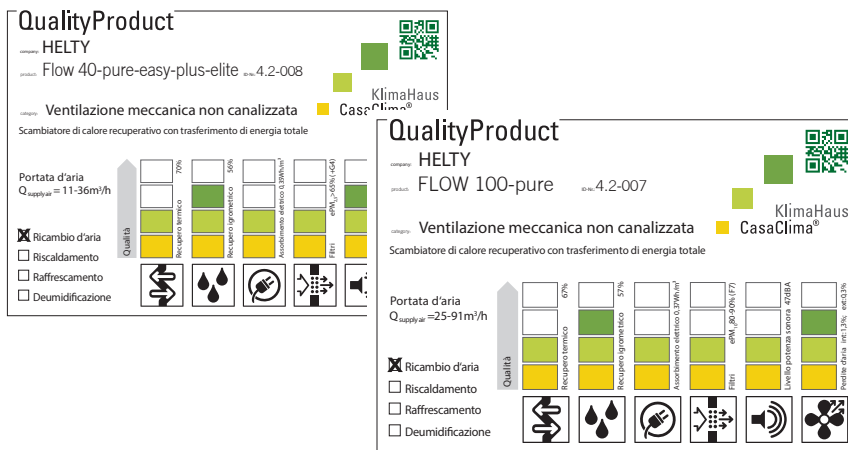

Specifically, the **KlimaHaus HRV Quality Seal** evaluates the five main ventilation system characteristics listed in the **UNI EN13141-7/-8** standards: thermal and hygrometric recovery, electrical consumption, filtration, acoustics and air leakage, assigning each of them a value according to the performance level.

The description of the product, the values attributed, and any further characteristics of the unit are included in a summary label, which helps users choose the most suitable solution for their needs.

BioSafe Validation

For the protection of health and air quality

Helty Flow systems have been submitted for an analytical process, fully complying with the **Biosafe® Environmental Health Certification Protocol** for verification, design and management of the indoor air quality index in highly energy-efficient buildings.

Through a **patented certification protocol**, Biosafe has submitted Helty Flow HRV solutions for careful analysis according to strict emission quality standards. The process was carried out on two levels: by **taking and verifying air samples** with CG-MS (pursuant to UNI-EN-ISO 16000-9 and 16000-6) and through **environmental surveys** (pursuant to UNI-EN-ISO 16000-4 and UNI-EN-ISO 16017-2 with reference to UNI-EN 14412 requirements), through the use of the product in the field and subsequent on-site analysis of the effects on indoor air quality.

The Biosafe® Validation Seal is a further guarantee of **living well-being**, both at the design level and in terms of indoor comfort when the installation is complete.

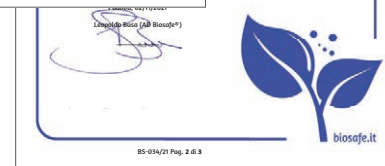

Validazione

Costituirà la parte integrante del presente Certificato e viene rilasciata al fine di attestare la validità

A DELL'ATTO DI NOTORIETA' 22/2009, n. 445) 03/07/2011, residente a Padova in via Galvani n.8, CF 014948287, titolare e responsabilità limitata 0151596287, consapevole delle sanzioni penali, nel richiamo dell'art.76 DPR 28/12/2000, n. 445, per la validità del presente Certificato di Validazione sono in possesso dei requisiti predefiniti di prodotto di segretezza e possono essere esibiti solo presso

gli effetti di cui all'art. 13 del D.Lgs. 196/2003 (Tutela e presente dichiarazione saranno trattati, anche con e per le finalità del procedimento per il quale la

ErP Directive Compliance

Ecodesign and energy labelling

All Hely mechanical ventilation systems fully meet the energy requirements set out by the European directive ErP (Energy Related Products), created with the aim of improving the efficiency of devices marketed in the European Union to support environmental protection.

The Community Directive has two areas of impact on ventilation systems:

// **Directive 2009/125/EC Ecodesign** requires minimum energy performance values that must be achieved by household appliances.

The Ecodesign regulation relating to ventilation systems (no. 1253/2014) sets out the energy performance requirements that are applied to products released from 1st January 2016. These requirements were reinforced on 1 January 2018.

// **Directive 2010/30/EU Energy Labelling** requires an assessment of the energy efficiency class of the device (A to G) in order to promote the purchase of more efficient products.

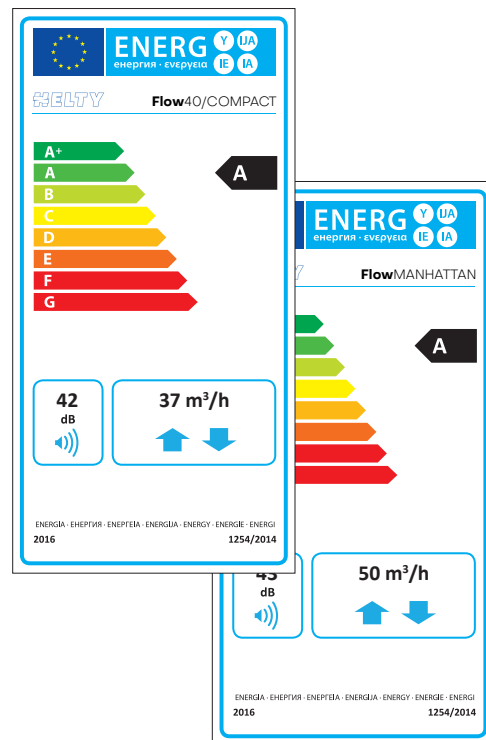

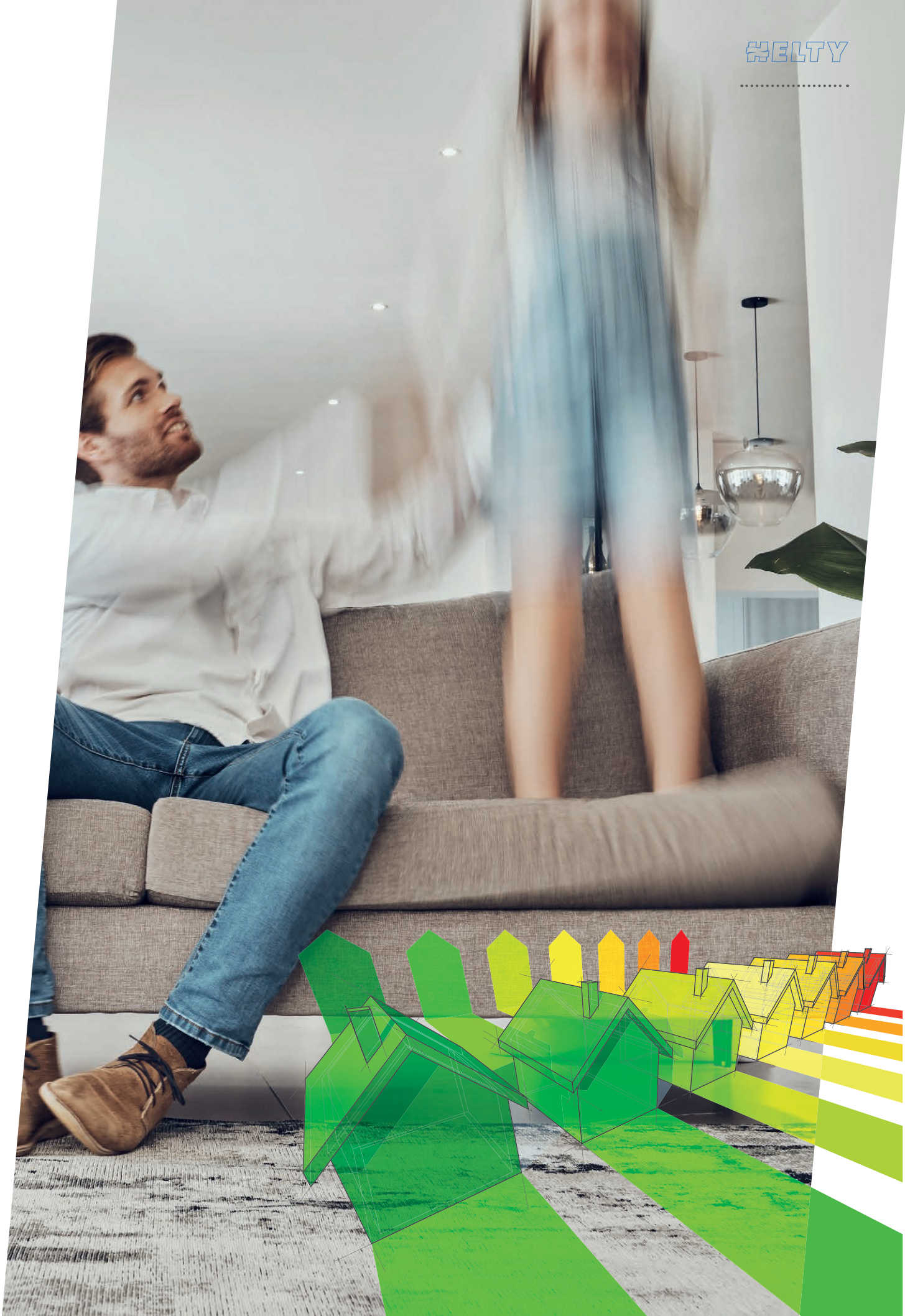

Indoor air quality

What do we breathe?

Every day, **we spend about 90% of our time indoors**, mainly at home and in the workplace. Confined environments have a limited amount of air, which we consume with every breath. People take on average **22,000 breaths a day**, processing about **12,000 litres of air through their lungs**.



Indoor air is up to 20 times more polluted

It is important for our health to breathe air that is clean, rich in oxygen and free of the pollutants that unfortunately accumulate and concentrate in closed, unventilated rooms.

As confirmed by numerous studies, **indoor air can be 5 to 20 times more polluted than external air**. Without proper ventilation, indoor air tends to deteriorate, becoming saturated with harmful substances that can be very dangerous to health.

Harmful elements include **ultra-fine dust, fumes, combustion gases, formaldehyde, volatile organic compounds** released by chemical detergents, glues and furniture materials. And moreover, pollutants of biological origin – micro-organisms such as **allergens, moulds, bacteria and viruses** carried by aerosols – and of physical origin such as the dreaded **radon gas**.

Main pollutants and health impacts



Particulates

cause eye, nose and throat irritation and breathing problems, headaches, fatigue and low concentration. Prolonged contact can lead to heart and respiratory diseases.

Viruses

viral agents can be emitted simply by coughing or breathing and circulate in the air in the form of bioaerosols for some time



Moulds

release health-damaging spores that cause allergies



Humidity

causes condensation, mould and dust mite proliferation



VOCs

airborne substances, including formaldehyde, which can cause respiratory tract irritation or central nervous system disorders

Radon

odourless and colourless radioactive gas of natural origin released from the soil. It qualifies as the second leading cause of risk for lung cancer



CO₂

in excessive levels, such as when experiencing the sensation of stale air, causes headaches and difficulty in concentration



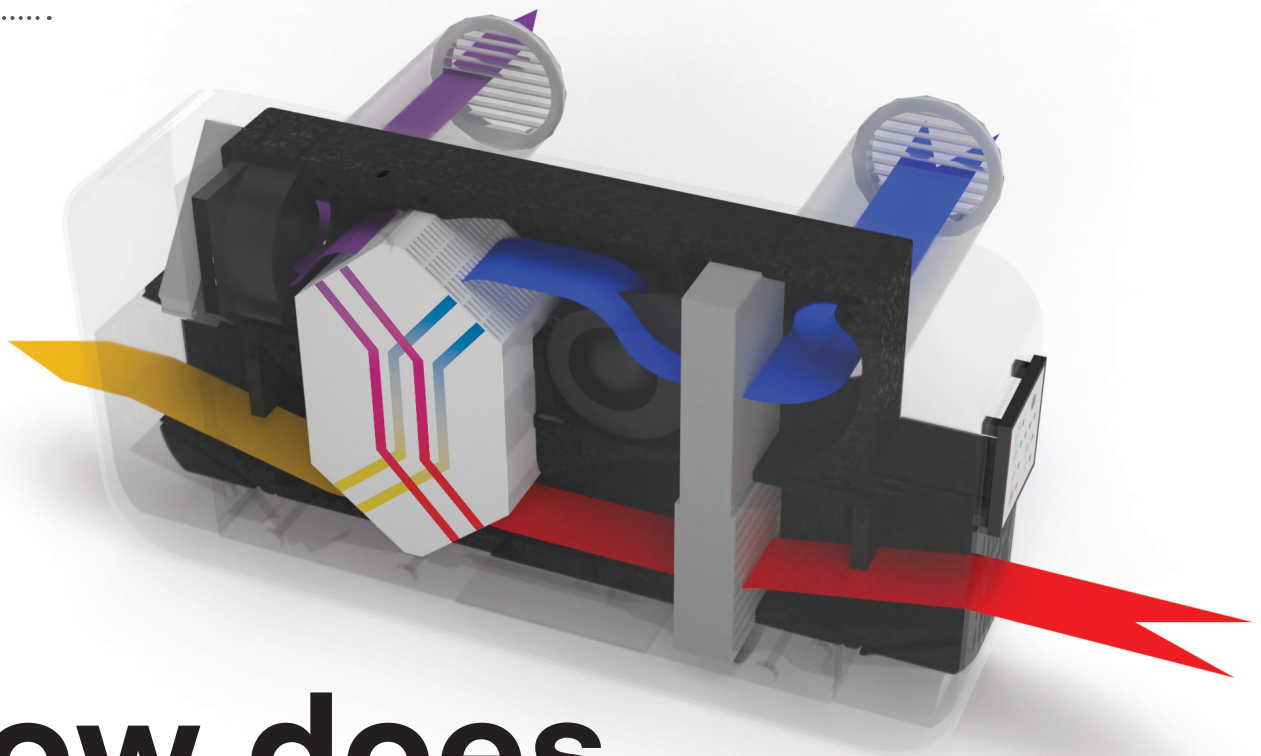

- stale indoor air is extracted
- stale air is expelled outside
- fresh outside air is conveyed inside
- intake air is filtered and pre-heated

How does it work?

Helty Flow: continuous air exchange and filtration

All Helty ventilation units are **decentralised HRVs with dual continuous flow** and counter-current crossed air flows.

Stale air, saturated with humidity and CO₂, is extracted from indoor areas and forced to flow into the heat exchanger where -- without contact between the two flows -- its heat is transferred to the incoming air flow simultaneously pumped in

from outside. **The fresh air, which is richer in oxygen, is pre-heated and purified** by a high-performance filter that traps smog, particulates and pollen. This technology provides **constant and balanced air exchange** in closed environments, ensuring **superior performance** in terms of energy efficiency, air purification and indoor comfort.

Healthiness and energy saving

Energy saving is optimised by the enthalpy heat exchanger, which **recovers up to 91% of thermal energy in both summer and winter** with TÜV SÜD-certified performance according to EN 13141-8. The **F7 filter (ePM2.5 65%)** prevents the entry not only of dust and pollen, but also of PM10 and PM2.5 particles, protecting the **healthiness of the air** you breathe in your home. Quiet operation and verified noise reduction values on facades contribute to **optimal acoustic comfort**.



PM10

PM2.5

Purified air

The benefits of HRV

it ensures that ambient air is always renewed and rich in oxygen

it counteracts the airborne spread of viruses and bacteria

it filters external air from particulates and pollen

it removes excess humidity, counteracting condensation and mould problems

it dilutes CO₂ and pollutants in indoor air

it decreases allergens and mites

it reduces fumes and bad smells

it mitigates the risk of radon gas

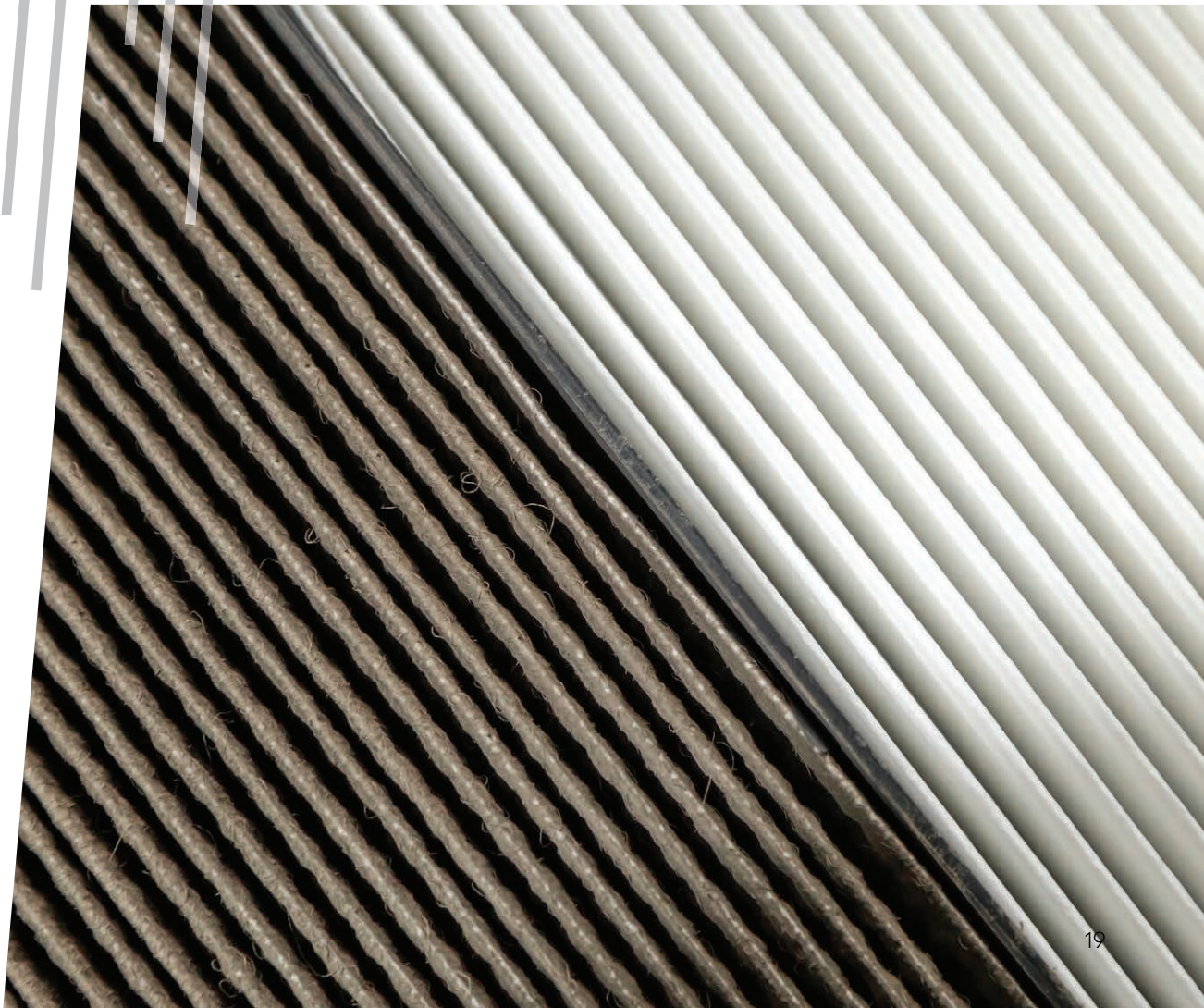



HRV Flow range

Wall-mounted

Point-wise systems for retrofits on existing buildings



FlowEASY FlowEASY-UV



FlowPLUS FlowELITE



FlowULTRA

Wall recessed

Built-in wall systems for renovations and new buildings

For redevelopment

Patented HRV system installed in the external wall insulation, without impacting the facade

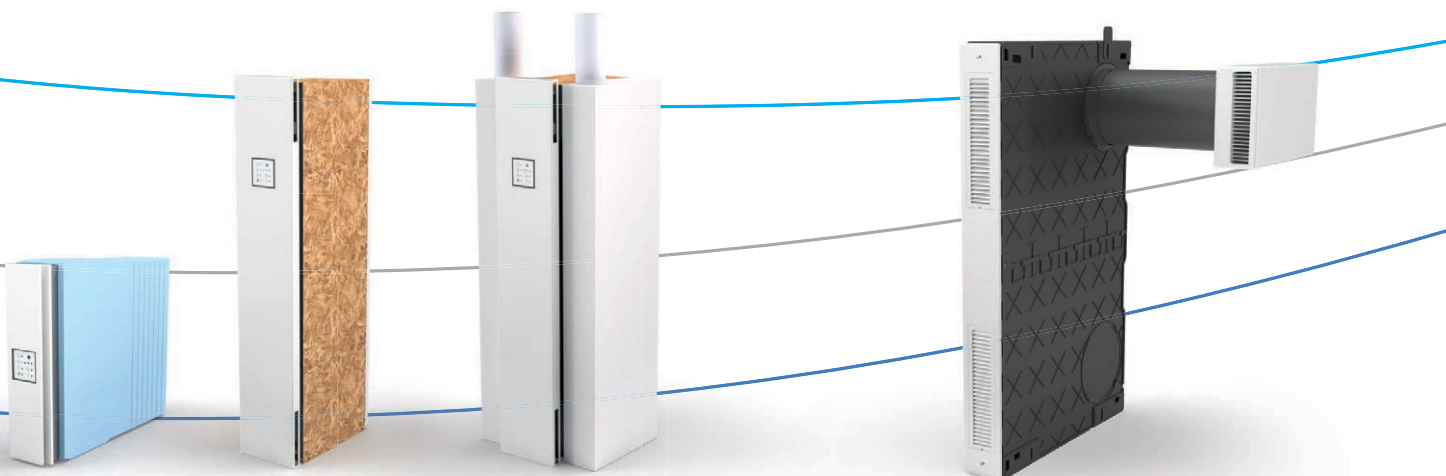

Flow40

Flow120

Flow©120

FlowMANHATTAN



Find out
all product
details

Community

Systems for air recovery and sanitation
in schools, offices, laboratories and small shops

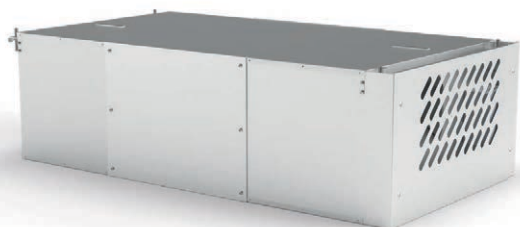

Flow600^{Steel}



Flow1000 / 1000^{Silent} / M1000

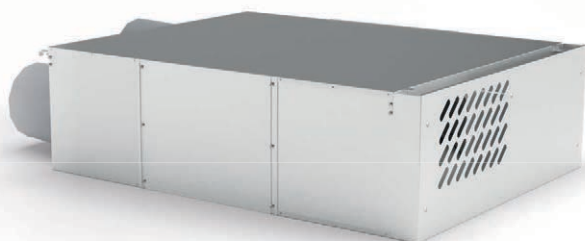

Flow800 / 800^{Steel} / 800^{Silent} / M800

.....

Wall-mounted HRV

Point-wise systems for retrofits on small-sized rooms in existing buildings



Model	FlowEASY	FlowEASY-UV	FlowPLUS	FlowELITE
Night function	✓	✓	✓	✓
Hyperventilation	✓	✓	✓	✓
Filter replacement alert	✓	✓	✓	✓
Remote control	✓	✓	✓	✓
UV-C lamp	-	✓	-	-
Free Cooling	-	✓	✓	✓
On/Off panel LED	-	✓	✓	✓
Humidity sensor	-	-	✓	✓
Air Guard App	-	-	✓	✓
Color Trust	-	-	✓	✓
CO ₂ and VOC sensor	-	-	-	✓
LED interface	-	-	-	✓
TÜV-tested (std. EN 13141-8)	✓	✓	✓	✓





Flow EASY

Compact and functional

Helty FlowEASY is a point-wise controlled mechanical ventilation system that extracts stale air from the indoor environments and injects new, oxygenated and clean air thanks to the special F7+G4 filters fitted as standard. The extremely compact dimensions of Helty FlowEASY make it **suitable for installation even in small spaces. Ideal for a quick and easy retrofit.**

FlowEASY is designed to bring the advantages and comfort of **continuous dual-flow HRV** to individual rooms in already inhabited buildings, where an adequate air exchange is needed, even at night thanks to the night mode.

It is ideal for rooms of up to 20 square metres. Installation is simple and maintenance is reduced to the bare essentials: simply **replace the filter yourself** when alerted to do so by the panel warning LED, no need to call a service technician.





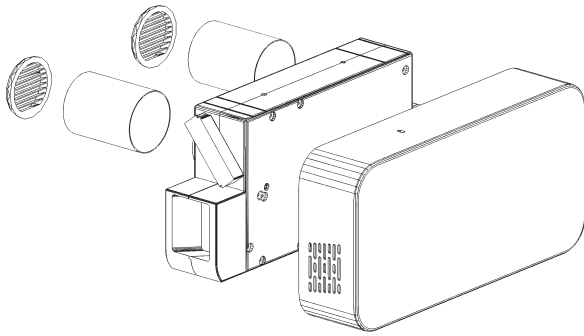

*Installed
in less than one hour*

Wall installation is very quick and does not require any particularly expensive or invasive work. It is necessary to drill two 8-cm diameter through holes in the perimeter masonry and connect the system to the power supply. Helty FlowEASY can also be installed vertically in case of very small spaces.



Thanks to the supplied infrared remote control, it is easy to operate from anywhere in the room.

 91% Heat recovery efficiency	 18 dB(A) Sound pressure	 42 m ³ /h Maximum air flow	 F7+G4 Air intake filtration	 -36.7 kWh/m ² a SEC energy consumption (temperate climate)
---	--	--	---	--

Technical data

Energy efficiency class **A**

Specifications	UoM	Value
Air flow rate	m ³ /h	10/17/26/37/42 ⁽¹⁾
Flow adjustment		4 stages + hyperventilation
Power consumption	W	3.6/5.5/9/17.5/20 ⁽¹⁾
Specific power input	W/m ³ /h	0.35/0.32/0.35/0.49/0.48 ⁽¹⁾
Power supply voltage	V AC	230
Operating voltage ⁽²⁾	V DC	24
Max. current consumption ⁽³⁾	A	0.17
Weight	kg	3
Product dimensions (H x W x D)	mm	560 x 280 x 120
Core-drilled holes	mm	2x Ø80
Heat exchanger		enthalpy with cross-flow countercurrent
Heat recovery efficiency	%	91
Sound power level ⁽⁴⁾	dB(A)	29.5/34.9/42/50.7
Sound pressure ⁽⁵⁾	dB(A)	18/23.4/30.5/39.2
Facade noise abatement Dn, e, w	dB	45
Filters (intake / extraction)		F7+G4 / G2
Energy efficiency class (cold / temperate / hot)		A+ / A / E
SEC (cold / temperate / hot)	kWh/m ² a	-73.8 / -36.7 / -13.3
Unit type		UVR-B bidirectional
Specific Power Input SPI ⁽⁶⁾	W/(m ³ /h)	0.35
Internal leakage rate ⁽⁶⁾	%	0.8
External leakage rate ⁽⁶⁾	%	0.9
Air flow sensitivity (variations +20 Pa to -20 Pa)		Class S1
Internal/external air tightness		Class S1

1. In hyperventilation mode

2. The use of the supplied power supply allows power to be supplied at 230 V AC. To be connected during installation.

3. With 230 V AC supply voltage

4. According to UNI 3744:2010

5. Measured in a 30 m² semi-anechoic environment at a distance f 3 m

6. In accordance with EN 13141-8:2014-09



Flow EASY-UV

*The wall-mounted HRV
that exchanges and purifies air*

Hely FlowEASY-UV is an **automatic air exchange and sanitisation** system that integrates the advantages of a HRV with the sterilising and germicidal power of UV technology. In addition to the dual filter, this unit incorporates a **259 nm UV-C lamp** which uses ultraviolet radiation to destroy viruses and volatile substances to purify the air. The high level of purity of the intake air and the abatement of pollutants, thanks to the combined action against viruses, bacteria and contaminants, ensures the healthiness of the confined environment.

The enthalpy heat recovery system facilitate the achieving of the **thermal comfort in all seasons**. The unit **does not require ducting** and can be easily installed on any external wall. Ease of use, compact dimensions and dual ventilation-purification feature make Hely Flow UV the **all-in-one retrofit solution for increasing healthiness and safety** in existing homes.



*Healthy air at home
thanks to UV*



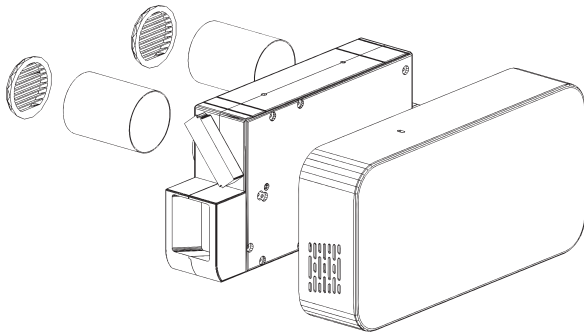

UV lamps are commonly used in hospital settings for their strong germicidal effect. UV-C radiation wavelengths counteract even the smallest microorganisms like viruses, reducing their infectious load and hindering their reproductive cycles.



Thanks to the supplied infrared remote control, it is easy to operate from anywhere in the room.



UV lamps that counteracts even the smallest micro-organisms such as viruses.

 91% Heat recovery efficiency	 18 dB(A) Sound pressure	 42 m ³ /h Maximum air flow	 F7+G4 Air intake filtration	 -37.9 kWh/m ² a SEC energy consumption (temperate climate)
---	--	--	---	--

Technical data

Energy efficiency class **A**

Specifications	UoM	Value
Air flow rate	m ³ /h	10/17/26/37/42 ⁽¹⁾
Flow adjustment		4 stages + hyperventilation
Power consumption (excluding UV lamp)	W	3.6/5.5/9/17.5/20 ⁽¹⁾
Specific Power Input (excluding UV lamp)	W/m ³ /h	0.35/0.32/0.35/0.49/0.48 ⁽¹⁾
UV Power consumption	W	7.5
Power supply voltage	V AC	230
Operating voltage ⁽²⁾	V DC	24
Max. current consumption ⁽³⁾	A	0.83
Weight	kg	3
Product dimensions (horizontal W x H x D)	mm	560 x 280 x 120
Core-drilled holes	mm	2x Ø80
Heat exchanger		enthalpy with cross-flow countercurrent
Heat recovery efficiency	%	91
Sound power level ⁽⁴⁾	dB(A)	29.5/34.9/42/50.7
Sound pressure ⁽⁵⁾	dB(A)	18/23.4/30.5/39.2
Facade noise abatement Dn, e, w	dB	45
Filters (intake / extraction)		F7+G4 / G2
Energy efficiency class (cold / temperate / hot)		A+ / A / E
SEC (cold / temperate / hot)	kWh/m ² a	-741 / -37.9 / -14.6
Unit type		UVR-B bidirectional
Specific Power Input SPI ⁽⁶⁾	W/(m ³ /h)	0.35
Internal leakage rate ⁽⁶⁾	%	0.8
External leakage rate ⁽⁶⁾	%	0.9
Air flow sensitivity (variations +20 Pa to -20 Pa)		Class S1
Internal/external air tightness		Class S1

1. In hyperventilation mode

2. The use of the supplied power supply allows power to be supplied at 230 V AC. To be connected during installation.

3. With 230 V AC supply voltage

4. According to UNI 3744:2010

5. Measured in a 30 m² semi-anechoic environment at a distance f 3 m

6. In accordance with EN 13141-8:2014-09



Flow PLUS

Automatic and silent

Helty FlowPLUS is a point-wise HRV with dual continuous flow, **enthalpy heat recovery system** and high-performance air filtration. The unit is equipped with a **hygrometric sensor that monitors the level of humidity in the air and automatically adjusts ventilation to counteract the formation of condensation and ensure humidity level within the comfort zone.** Featuring a **clean minimal design**, it can be easily installed on external masonry without invasive renovation work.

Thanks to the enthalpy heat exchanger, the system **recovers up to 91% of the heat** from the outgoing air, using it to heat the incoming air before introducing it into the rooms. With a **sound pressure level of 18 dB at minimum speed**, it is incredibly quiet. It is imperceptible even during sleeping hours thanks to the night function.



Humidity under control

In addition to the panel interface and remote control, the appliance can be managed via smartphone over a home Wi-Fi network using the **Air Guard app**, which enables you to adjust its operation and **monitor the temperature and humidity levels** in your home.

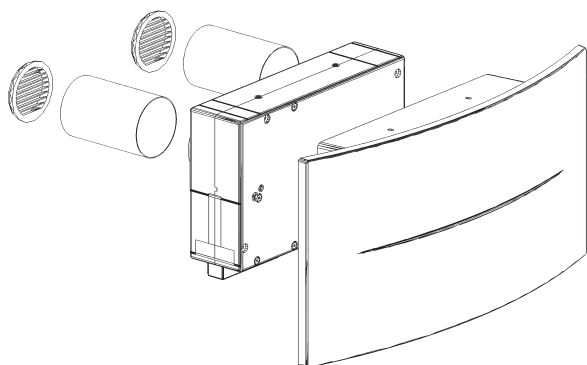

Humidity sensor for automatic ventilation regulation.



Thanks to the supplied infrared remote control, it is easy to operate from anywhere in the room.



91%

Heat recovery efficiency



18 dB(A)

Sound pressure



42 m³/h

Maximum air flow



F7+G4

Air intake filtration



-37.9 kWh/m²a

SEC energy consumption (temperate climate)

Technical data

Energy efficiency class **A**

Specifications	UoM	Value
Air flow rate	m ³ /h	10/17/26/37/42 ⁽¹⁾
Flow adjustment		4 stages + hyperventilation
Power consumption	W	3.6/5.5/9/17.5/20 ⁽¹⁾
Specific power input	W/m ³ /h	0.35/0.32/0.35/0.49/0.48 ⁽¹⁾
Power supply voltage	V AC	230
Operating voltage ⁽²⁾	V DC	24
Max. current consumption ⁽³⁾	A	0.17
Weight	kg	6
Product dimensions (horizontal W x H x D)	mm	695 x 353 x 152
Core-drilled holes	mm	2x Ø80
Heat exchanger		enthalpy with cross-flow countercurrent
Heat recovery efficiency	%	91
Sound power level ⁽⁴⁾	dB(A)	29.5/34.9/42/50.7
Sound pressure ⁽⁵⁾	dB(A)	18/23.4/30.5/39.2
Facade noise abatement Dn, e, w	dB	45
Filters (intake / extraction)		F7+G4 / G2
Modbus RTU rs485		Yes ⁽⁶⁾
Energy efficiency class (cold / temperate / hot)		A+ / A / E
SEC (cold / temperate / hot)	kWh/m ² a	-741 / -37.9 / -14.6
Unit type		UVR-B bidirectional
Specific Power Input SPI ⁽⁷⁾	W/(m ³ /h)	0.35
Internal leakage rate ⁽⁷⁾	%	0.8
External leakage rate ⁽⁷⁾	%	0.9
Air flow sensitivity (variations +20 Pa to -20 Pa)		Class S1
Internal/external air tightness		Class S1

1. In hyperventilation mode
 2. The use of the supplied power supply allows power to be supplied at 230 V AC. To be connected during installation.

3. With 230 V AC supply voltage
 4. According to UNI 3744:2010
 5. Measured in a 30 m² semi-anechoic environment at a distance f 3 m

6. This excludes control via the panel interface
 7. In accordance with EN 13141-8:2014-09



Flow ELITE

Elegant and smart

FlowELITE is equipped with a humidity sensor, CO₂ and VOC sensors, Color Trust technology, LED lighting kit and mobile app control. Like the other Flow models, it ensures superior heat recovery and pollutant filtration performance, also adding advanced features that enable it **to blend into room decor, providing comfort and well-being.**

The design cover incorporates **dimmable and timer-controlled LEDs** on the sides to create atmospheric accessory lighting, particularly suitable for living room installations. Operation is automatically regulated by the **humidity, CO₂ and VOC sensors**, to prevent excessive pollutant concentrations, increase air renewal and improve oxygenation.



*Healthy air
at your fingertips
with the app*

The Color Trust light sensor reports the air quality in the home, informing the user intuitively when indoor pollutant values are ideal or too high. The Air Guard app makes HRV even easier to use by allowing the **integrated management of Heat Recovery Ventilation (HRV) systems** and also providing air quality values from sensors.

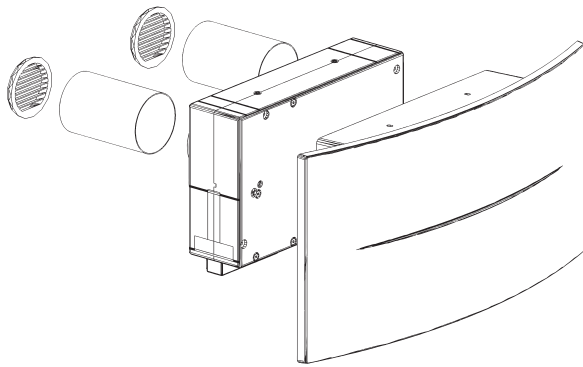

Sensors for automatic humidity, CO₂ and VOC management



Thanks to the supplied infrared remote control, it is easy to operate from anywhere in the room.



Dimmable LED lighting kit.



91%

Heat recovery efficiency



18 dB(A)

Sound pressure



42 m³/h

Maximum air flow



F7+G4

Air intake filtration



-37.9 kWh/m²a

SEC energy consumption (temperate climate)

Technical data

Energy efficiency class **A**

Specifications	UoM	Value
Air flow rate	m ³ /h	10/17/26/37/42 ⁽¹⁾
Flow adjustment		4 stages + hyperventilation
Power consumption (excluding LED lighting)	W	3.6/5.5/9/17.5/20 ⁽¹⁾
Specific Power Input (excluding LED lighting)	W/m ³ /h	0.35/0.32/0.35/0.49/0.48 ⁽¹⁾
LED lighting consumption	W	12
Power supply voltage	V AC	230
Operating voltage ⁽²⁾	V DC	24
Max. current consumption ⁽³⁾	A	0.17
Weight	kg	6
Product dimensions (horizontal W x H x D)	mm	695 x 353 x 152
Core-drilled holes	mm	2x Ø80
Heat exchanger		enthalpy with cross-flow countercurrent
Heat recovery efficiency	%	91
Sound power level ⁽⁴⁾	dB(A)	29.5/34.9/42/50.7
Sound pressure ⁽⁵⁾	dB(A)	18/23.4/30.5/39.2
Facade noise abatement Dn, e, w	dB	45
Filters (intake / extraction)		F7+G4 / G2
Modbus RTU rs485		Yes ⁽⁶⁾
Energy efficiency class (cold / temperate / hot)		A+ / A / E
SEC (cold / temperate / hot)	kWh/m ² a	-74.1 / -37.9 / -14.6
Unit type		UVR-B bidirectional
Specific Power Input SPI ⁽⁷⁾	W/(m ³ /h)	0.35
Internal leakage rate ⁽⁷⁾	%	0.8
External leakage rate ⁽⁷⁾	%	0.9
Air flow sensitivity (variations +20 Pa to -20 Pa)		Class S1
Internal/external air tightness		Class S1

1. In hyperventilation mode
2. The use of the supplied power supply allows power to be supplied at 230 V AC. To be connected during installation.

3. With 230 V AC supply voltage
4. According to UNI 3744:2010
5. Measured in a 30 m² semi-anechoic environment at a distance f 3 m

6. This excludes control via the panel interface
7. In accordance with EN 13141-8:2014-09

.....



Flow wall-mounted HRV dimensions

FlowEASY

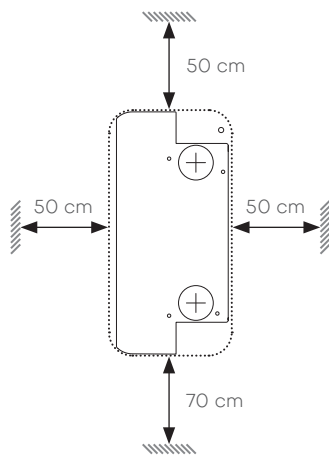
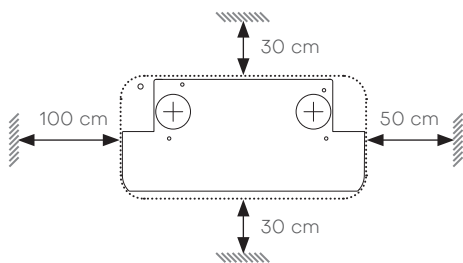
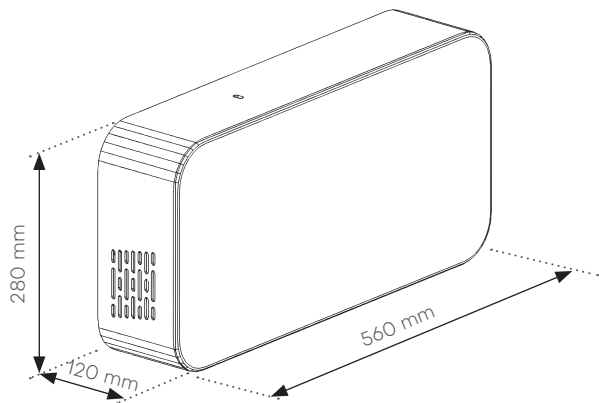

FlowPLUS - FlowELITE

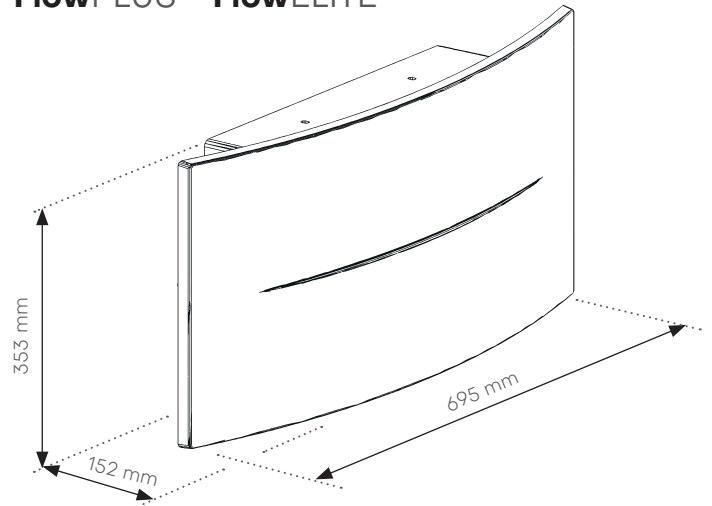

Horizontal orientation

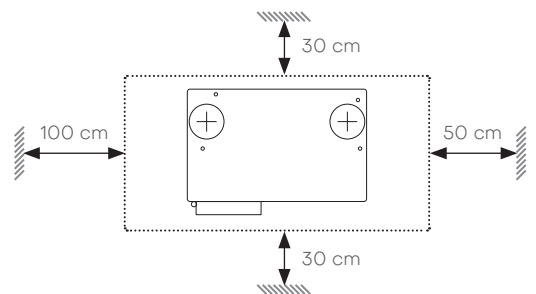

Vertical orientation

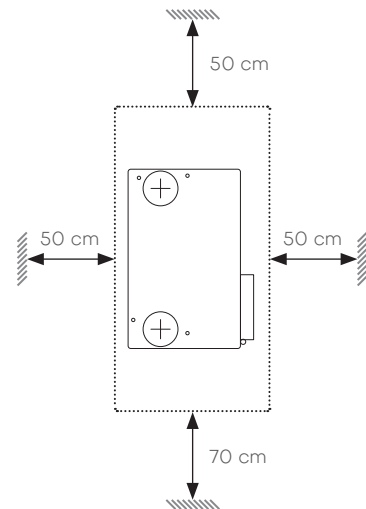

Flow wall-mounted HRV installation

Wall-mounted HRV systems allow plug-and-play installation. Fitting requires two small 80-mm core-drilled holes in the masonry, inserting and sealing the conduits in the masonry section, fixing the unit to the wall with pressure screws, electrical connection and positioning the external grilles. **With the 100 mm ducting kit (optional), the grilles can be installed directly from inside the house.**

For more details, please refer to the instruction manual. For improved air distribution and optimal acoustic comfort, the recommended installation position is a central point of a wall of the room to be ventilated, as high as possible (compatibly with the minimum recommended distances) and preferably in a horizontal configuration.

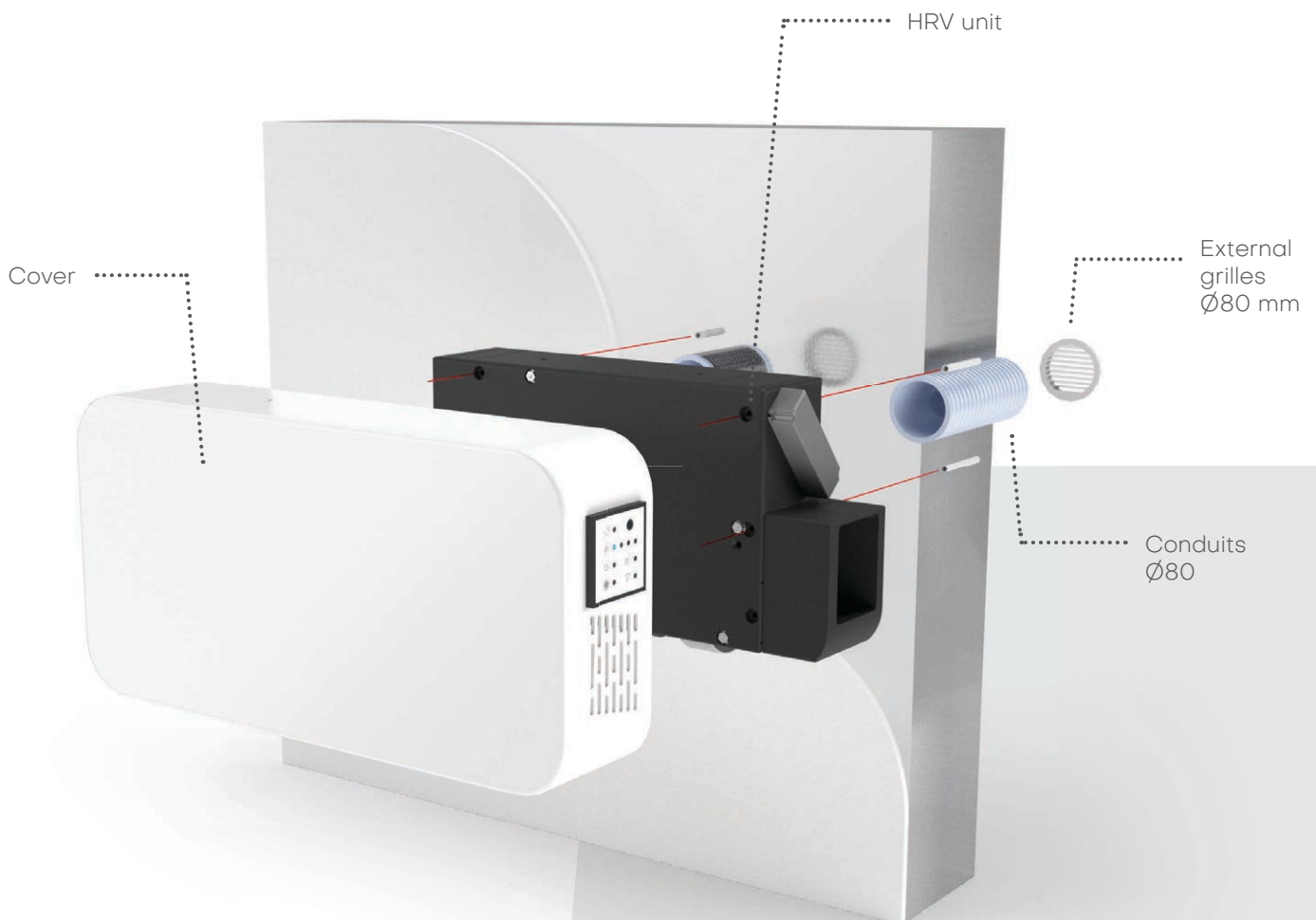

Wall-mounted HRV

.....

FlowEASY



FlowELITE



FlowPLUS



Wall-mounted HRV

Point-wise systems for retrofits
 on medium-sized rooms in existing buildings



Model	FlowULTRA		
	STD	Plus	Elite
Version			
Night function	✓	✓	✓
Hyperventilation	✓	✓	✓
Filter replacement alert	✓	✓	✓
Remote control	✓	✓	✓
On/Off panel LED	✓	✓	✓
Free Cooling	✓	✓	✓
Humidity sensor	-	✓	✓
Air Guard App	-	✓	✓
CO ₂ and VOC sensor	-	-	✓



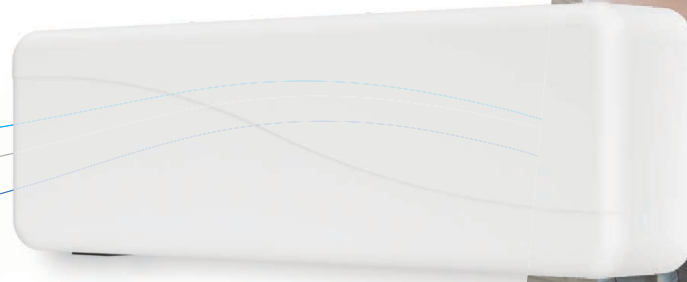

Flow ULTRA

Ideal for HRV retrofits in living spaces and small-sized offices

New in the 2023 catalogue, **FlowULTRA** represents the evolution of the retrofit HRV with wall installation due to the need to **ensure the correct air exchange in recently renovated environments**, while safeguarding the energy efficiency of the building envelope insulation. A continuous dual-flow ventilation unit designed to serve individual rooms with **modulated air flow rates between 15 and 120 m³/h**. The ventilation unit, which can be installed with two 100-mm diameter core-drilled holes on an external wall, is supplied as standard with a white ABS cover that allows **easy aesthetic**

matching with the existing environment.

The solution is designed to **counteract condensation and mould problems** and meet the need for **healthy air in medium-sized rooms** as well as in **small-sized offices, professional offices and practices.**

The **continuous exchange** of stale air with fresh air, combined with the **filtration of air** introduced from outside with an F7 filter, provides a healthier and more comfortable environment, eliminating dust, odours, spores and pollen. Energy savings are ensured by the **enthalpy heat recovery system with efficiency of up to 88%.**



Available in Standard, Plus and Elite versions

All FlowULTRA models come as standard with an infrared remote control to operate the unit. The Plus version is enhanced by the **Air Guard app**, a **sensor for humidity detection** and automatic ventilation operation. FlowULTRA Elite is the version dedicated to people who are more sensitive to indoor pollution: it also monitors **CO₂ and VOCs** by automatically varying the fresh air flow for the **correct dilution of pollutants** from the environment.

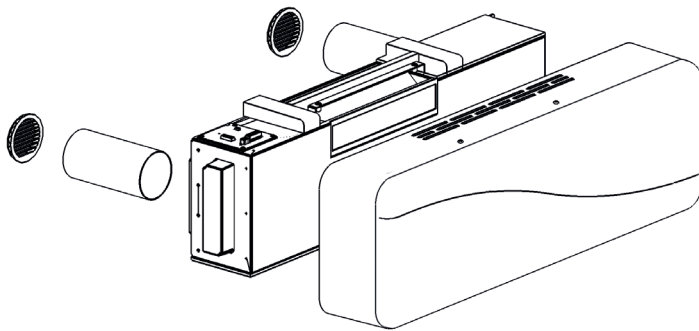

Sensors for automatic humidity, CO₂ and VOC management



Thanks to the supplied infrared remote control, it is easy to operate from anywhere in the room.



88%

Heat recovery efficiency



19.5 dB(A)

Sound pressure



120 m³/h

Maximum air flow



F7

Air intake filtration



-37.6 kWh/m²a

SEC energy consumption (temperate climate)

Technical data

Energy efficiency class **A**

Specifications	UoM	Value
Air flow rate	m ³ /h	15/30/45/60/80/120 ⁽¹⁾
Flow adjustment		night + 4 stages + hyperventilation
Power consumption	W	3/6/9/13/23/55 ⁽¹⁾
Specific power input	W/m ³ /h	0.2/0.2/0.2/0.22/0.29/0.46 ⁽¹⁾
Power supply voltage	V AC	230
Operating voltage ⁽²⁾	V DC	24
Max. current consumption ⁽³⁾	A	0.45
Weight	kg	14
Product dimensions (horizontal W x H x D)	mm	1000 x 320 x 180
Core-drilled holes	mm	2x Ø100
Heat exchanger		enthalpy with cross-flow countercurrent
Heat recovery efficiency	%	88
Sound power level ⁽⁴⁾	dB(A)	31/36/43/48/55/63
Sound pressure ⁽⁵⁾	dB(A)	19.5/24.5/31.5/36.5/43.5/51.5
Facade noise abatement Dn, e, w	dB	45
Filters (intake / extraction)		F7 / G1
Modbus RTU rs485		Yes ⁽⁶⁾
Energy efficiency class (cold / temperate / hot)		A+ / A / E
SEC (cold / temperate / hot)	kWh/m ² a	-71.6 / -37.6 / -15.5
Unit type		UVR-B bidirectional
Specific Power Input SPI ⁽⁷⁾	W/(m ³ /h)	0.22
Internal leakage rate ⁽⁷⁾	%	1.9
External leakage rate ⁽⁷⁾	%	0.8

1. In hyperventilation mode

2. The use of the supplied power supply allows power to be supplied at 230 V AC. To be connected during installation.

3. With 230 V AC supply voltage

4. According to UNI 3744:2010

5. Measured in a 30 m² semi-anechoic environment at a distance f 3 m

6. This excludes control via the panel interface in the FlowULTRA Plus and Elite versions

7. In accordance with EN 13141-8:2014-09

.....



FlowULTRA wall-mounted HRV dimensions

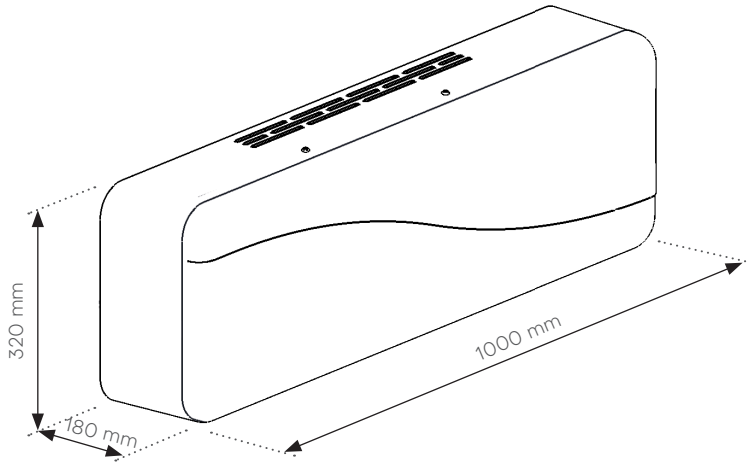

Horizontal orientation

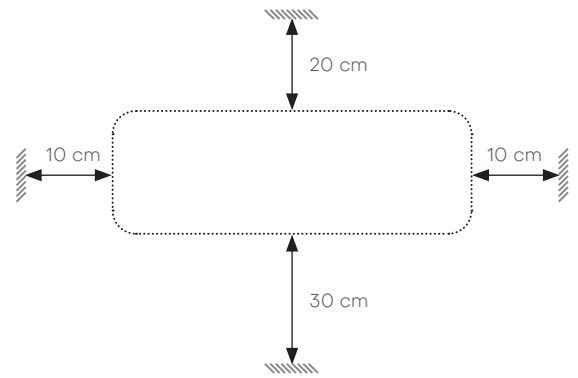

Extractor XTRA

Ideal for quickly extracting stale air from the bathroom

For situations where odours, stale air and fumes need to be extracted quickly in small and medium-sized rooms such as bathrooms, toilets, utility rooms, kitchens, cellars, laundries, etc. Made of high-quality, UV-resistant ABS in a modern design with a smooth front, it can be installed on the wall or ceiling.

Technical data

Specifications	UoM	Value
Maximum air flow	m ³ /h	88
Power consumption	W	14
Power supply	V - Phases - Hz	220-230 - 1 - 50
Dehum. appliance weight	kg	0.6
Dimensions (W x H x D)	mm	152 x 120 x 30
Sound pressure ⁽¹⁾	dB(A)	33
Core-drilled hole	mm	Ø100

1. Measured in a 30 m² semi-anechoic environment at a distance f 3 m

.....

Point-wise HRV: solutions compared

Point-wise HRV is the **ideal solution for the renewal of air in rooms and homes where it is either impossible or inconvenient to create a ducted air distribution system**. The alternative in these cases is between single alternating flow HRV systems and dual continuous flow HRV systems. Here are some aspects to consider carefully in order to make an informed choice.

Point-wise HRV with single alternating flow (push-pull)

Decentralised devices with single alternating cyclic flow are also called "push-pull" because of their operation, which consists of two phases in which the air is alternately blown (push) and sucked (pull) into the rooms in which they are installed. In the first phase, extracted air passes through a porous ceramic regenerative recuperator, yielding the heat it contains.

In the following phase, cold external air flows through the ceramic element and gains part of the previously accumulated heat. Studies and experiments recently conducted on this category of equipment have shown that **the average heat recovery efficiency is rather low**, about 20%, compared to peak values measured during the very first seconds of each cycle, which can reach 90%. These systems, due to their simplicity of construction, have a **low air intake filtration capacity**, and are alternately crossed by a flow of air in both directions, limiting the purification effect.

In addition, since they operate with two phases, one for intake and one for extraction, this category of devices is permanently unbalanced, i.e. it alternately generates depression and over-pressure in the rooms. To overcome this drawback, the devices **must be installed in pairs** with the operating cycles reversed and synchronised, so that, when one intakes, the other extracts and vice versa, with the inevitable **doubling of costs**. Only by installing the two devices can the actual flow rates be equal to those of a single device, with two balanced flows. Lastly, the construction peculiarities of these devices prevent an adequate level of facade noise abatement from being obtained, with the consequence of **bringing noise from outside into your home**, thus nullifying an investment in insulating fixtures.

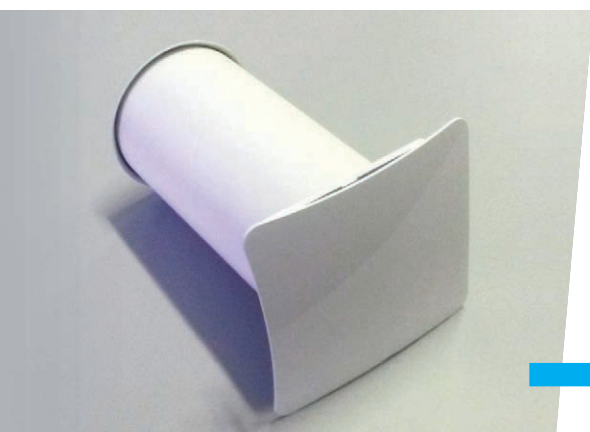

Example of point-wise single-conduit alternating single-flow HRV, also known as push-pull type

Point-wise HRV with dual continuous flow

The most modern decentralised controlled mechanical ventilation systems are those with dual continuous flow, equipped with a high efficiency heat exchanger, preferably of the enthalpy type and with forced filtration of intake air. They consist of **two electric fans of equal capacity** serving the same room, one extracting stale air and the other simultaneously taking in fresh air. **The two air flows, extraction and intake, are simultaneous and pass through the heat exchanger without ever coming into contact or contaminating each other.**

This category of devices offers **more efficient and constant heat recovery performance**, which reaches and even exceeds values of 90%. They are usually designed and built to correctly serve the ventilation needs of a single room or of rooms with a surface area of up to 40 square metres, featuring the undoubted advantage of being easy to install and maintain.

In addition, this type of units also achieves **good levels of facade noise abatement** due to its construction characteristics, and the installation therefore does not compromise the acoustic insulation of the rooms. Today's decentralised dual-flow balanced systems represent **the best combination of functionality, low consumption as well as ease and economy of installation, maintenance and operation.**

Average heat transfer efficiency

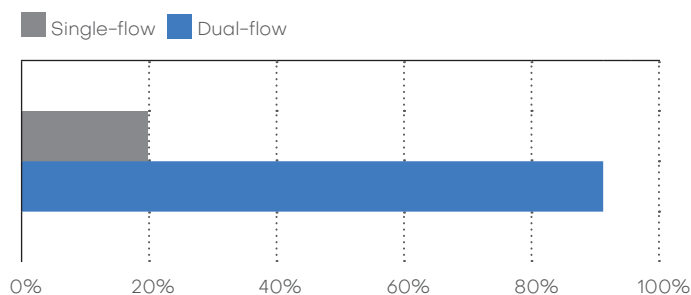

.....

Wall recessed HRV

Built-in systems for renovation and energy requalification



Model	Flow40		Flow120		FlowC120	
	STD	Pure	STD	Pure	STD	Pure
Version						
Night function	✓	✓	✓	✓	✓	✓
Hyperventilation	✓	✓	✓	✓	✓	✓
Filter replacement alert	✓	✓	✓	✓	✓	✓
Power supply	✓	✓	✓	✓	✓	✓
Humidity sensor	✓	✓	✓	✓	✓	✓
On/Off panel LED	✓	✓	✓	✓	✓	✓
Free Cooling	✓	✓	✓	✓	✓	✓
Air Guard App	-	✓	-	✓	-	✓
CO ₂ and VOC sensor	-	✓	-	✓	-	✓
TÜV-tested (std. EN 13141-8)	✓	✓	-	-	-	-
Ducting	-	-	-	-	✓	✓



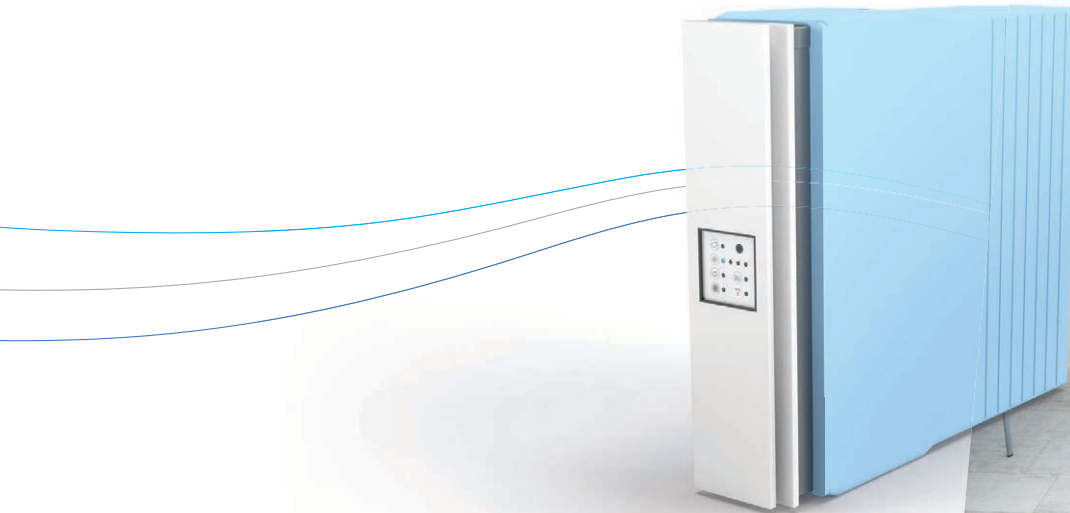

Flow40

Zero footprint,
maximum comfort

Hely Flow40 is a decentralised **built-in** solution, ideal especially for renovation and energy requalification. The HRV makes itself invisible by combining excellent air exchange performance with a **zero footprint**: Flow40 does not require ducting or false ceilings and **leaves only the cover exposed**, available in a white pre-painted metal or white or black Plexiglas variant visible. The recessed system is housed **in an Expanded Polystyrene setup, adaptable to walls of varying thickness**, which can be fitted during construction and completed with HRV units and covers at a later date.

The HRV unit is equipped with a dual cross-flow counter-current enthalpy heat exchanger, with 91% recovery efficiency and **dual F7 + G4/G2 filter** that purifies the fresh air and safeguards system performance. It has a **hygrometric sensor which continuously monitors humidity** to provide automatic ventilation regulation. The **electronic free-cooling function** contributes to passive cooling by introducing fresh air into the home in favourable outdoor temperature conditions.



Flow40^{Pure}

The Pure versions also include a **sensor for detecting CO₂ and VOC levels** with automatic adjustment of the air flow to maintain the sensation of well-being in the room. This version enables the management of all functions and monitoring of air quality values via the **Air Guard app**.

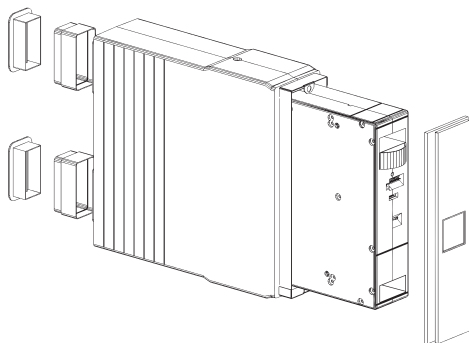

Sensors for automatic humidity, CO₂ and VOC management.



Zero footprint solution: completely recessed in the masonry.



91%

Heat recovery efficiency



15 dB(A)

Sound pressure



42 m³/h

Maximum air flow



F7+G4

Air intake filtration



-37.9 kWh/m²a

SEC energy consumption (temperate climate)

Technical data

Energy efficiency class **A**

Specifications	UoM	Value
Air flow rate	m ³ /h	10/17/26/37/42 ⁽¹⁾
Flow adjustment		4 stages + hyperventilation
Power consumption	W	3.6/5.5/9/17.5/20 ⁽¹⁾
Specific power input	W/m ³ /h	0.35/0.32/0.35/0.47/0.48 ⁽¹⁾
Power supply voltage	V AC	230
Operating voltage ⁽²⁾	V DC	24
Max. current consumption ⁽³⁾	A	0.17
Mass of HRV unit	kg	4
Unit dimensions (vertical W x H x D)	mm	108 x 408 x 268
Setup dimensions (vertical W x H x D)		145 x 473 x 517
Heat exchanger		enthalpy with cross-flow countercurrent
Heat recovery efficiency	%	91
Sound power level ⁽⁴⁾	dB(A)	26.5/32.4/37.8/46
Sound pressure ⁽⁵⁾	dB(A)	15/20.9/26.3/34.5
Facade noise abatement Dn, e, w	dB	45
Filters (intake / extraction)		F7+G4 / G2
Modbus RTU rs485		Yes ⁽⁶⁾
Energy efficiency class (cold / temperate / hot)		A+ / A / E
SEC (cold / temperate / hot)	kWh/m ² a	-741 / -37.9 / -14.6
Unit type		UVR-B bidirectional
Specific Power Input SPI ⁽⁷⁾	W/(m ³ /h)	0.35
Internal leakage rate ⁽⁷⁾	%	0.8
External leakage rate ⁽⁷⁾	%	0.9
Air flow sensitivity (variations +20 Pa to -20 Pa)		Class S1
Internal/external air tightness		Class S1

1. In hyperventilation mode

2. The use of the supplied power supply allows power to be supplied at 230 V AC. To be connected during installation.

3. With 230 V AC supply voltage

4. According to UNI 3744:2010

5. Measured in a 30 m² semi-anechoic environment at a distance f 3 m

6. In the Pure versions, this excludes control via the interface panel

7. In accordance with EN 13141-8:2014-09



Flow 120/C120

Even more compact, even quieter.
Now also ducted

Flow120 radically updates the previous Flow70/100 models and is the perfect answer for everyday environments that require **more air exchange, without sacrificing quietness and comfort.**

Versatile and performing, Flow120 is adjustable on 4 air flow speeds as well as offering night mode and hyperventilation functions: **the range from 15 m³/h up to 120 m³/h** allows it to meet the ventilation needs of **modern residential living spaces** or **small-sized offices** in the tertiary sector. Easy to install, the HRV unit has been **re-engineered to minimise footprint**, with a width of just 16 cm and height of only 92 cm. The choice of **different types of covers** also ensures greater integration into

the home environment. The setup for built-in wall installation allows work even on external masonry just 34.5 cm thick. Great attention is paid to quiet operation, with a **sound power level of less than 40 dB(A) at the working flow rate (60 m³/h)**, and to energy efficiency with **88% heat recovery.** The unit is available in standard version, which is already equipped with a **hygrometric sensor** as standard, and in Pure version, which also includes the **CO₂ + VOC sensor** and the control of the units via the Air Guard app using the home Wi-Fi network for ease of use.

Flow C120: Helty's first ducted HRV

The **FlowC120** ducted model offers an even more versatile system in **HRV system design, serving multiple rooms** within living units. This version, with **ducted supply and extraction air flows of up to 8 metres***, offers the possibility of partitioning air supply and suction in the room of installation, taking stale air from a bathroom and injecting fresh air into an adjacent room such as a bedroom. A smart solution, ideal e.g. for three-room apartments, to reduce the cost of building a HRV system and manage the **air exchange over adjacent rooms with a single decentralised ventilation unit.**

* for details on the dimensions of the ducting see the technical manual

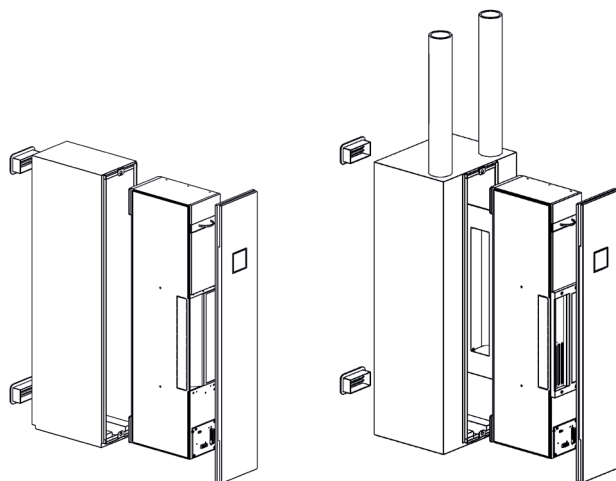

Zero footprint solution: completely recessed in the masonry.



Sensors for automatic humidity, CO₂ and VOC management.



Possibility of serving several rooms in the ducted version.



88%

Heat recovery efficiency



18.5 dB(A)

Sound pressure



120 m³/h

Maximum air flow



F7

Air intake filtration



-37.6 kWh/m²a

SEC energy consumption (temperate climate)

Technical data

Energy efficiency class **A**

Specifications	UoM	Flow120	Flow [®] 120
Air flow rate	m ³ /h	15/30/45/60/80/120 ⁽¹⁾	
Flow adjustment		night + 4 stages + hyperventilation	
Power consumption	W	3/6/9/13/23/55 ⁽¹⁾	
Specific power input	W/m ³ /h	0.2/0.2/0.2/0.22/0.29/0.46 ⁽¹⁾	
Power supply voltage	V AC	230	
Operating voltage ⁽²⁾	V DC	24	
Max. current consumption ⁽³⁾	A	0.45	
Mass of HRV unit	kg	10	
Unit dimensions (vertical W x H x D)	mm	160 x 920 x 286	
Setup dimensions (vertical W x H x D)		190 x 990 x 345	390 x 990 x 345
Conduit connection diameter	mm	-	Ø78
Heat exchanger	mm	enthalpy with cross-flow countercurrent	
Heat recovery efficiency	%	88	
Sound power level ⁽⁴⁾	dB(A)	30/31/35/40/47/54	
Sound pressure ⁽⁵⁾	dB(A)	18.5/19.5/23.5/28.5/35.5/42.5	
Facade noise abatement Dn, e, w	dB	45	
Filters (intake / extraction)		F7 / G1	
Modbus RTU rs485		Yes ⁽⁶⁾	
Energy efficiency class (cold / temperate / hot)		A+ / A / E	
SEC (cold / temperate / hot)	kWh/m ² a	-71.6 / -37.6 / -15.5	
Unit type		UVR-B bidirectional	
Specific Power Input SPI ⁽⁷⁾	W/(m ³ /h)	0.22	
Internal leakage rate ⁽⁷⁾	%	1.9	
External leakage rate ⁽⁷⁾	%	0.8	

1. In hyperventilation mode

2. The use of the supplied power supply allows power to be supplied at 230 V AC. To be connected during installation.

3. With 230 V AC supply voltage

4. According to UNI 3744:2010

5. Measured in a 30 m² semi-anechoic environment at a distance f 3 m

6. In the Pure versions, this excludes control via the interface panel

7. In accordance with EN 13141-8:2014-09



Adaptable cover may be customised to blend in with any decor

These wall recessed HRV systems may be finished with different covers, depending on their installation context. The **cover is available in ABS or white pre-painted sheet metal***, which can also be painted if required to blend with the room decor. Or you can opt for the **plexiglass cover** that offers a convenient **magnetic clip system** for easy filter replacement. The plexiglass cover is available in both white and black.



*ABS cover only available for Flow40, sheet metal only available for Flow120.



Wall recessed HRV installation

The setup for the installation of Helly Flow HRV units is a three-step process:

1. a rectangular hole is cut into the wall according to the shape required by the type of device to be installed (see pages 52 and 53);
2. the setup is fitted in the wall, including external vents and the edges are then sealed with flexible polyurethane foam;
3. the HRV unit is inserted and connected to the power supply; the inner cover is fitted.

For more details, please refer to the instruction manual. The setup can be purchased separately for prior installation in the masonry during the construction phase; it can then be completed at any time later with the assembly of the HRV device and cover.

Slim grille accessory



* Slim 40x180 mm external grilles are also available (via accessory kit) for Flow40 as an alternative to standard ones.

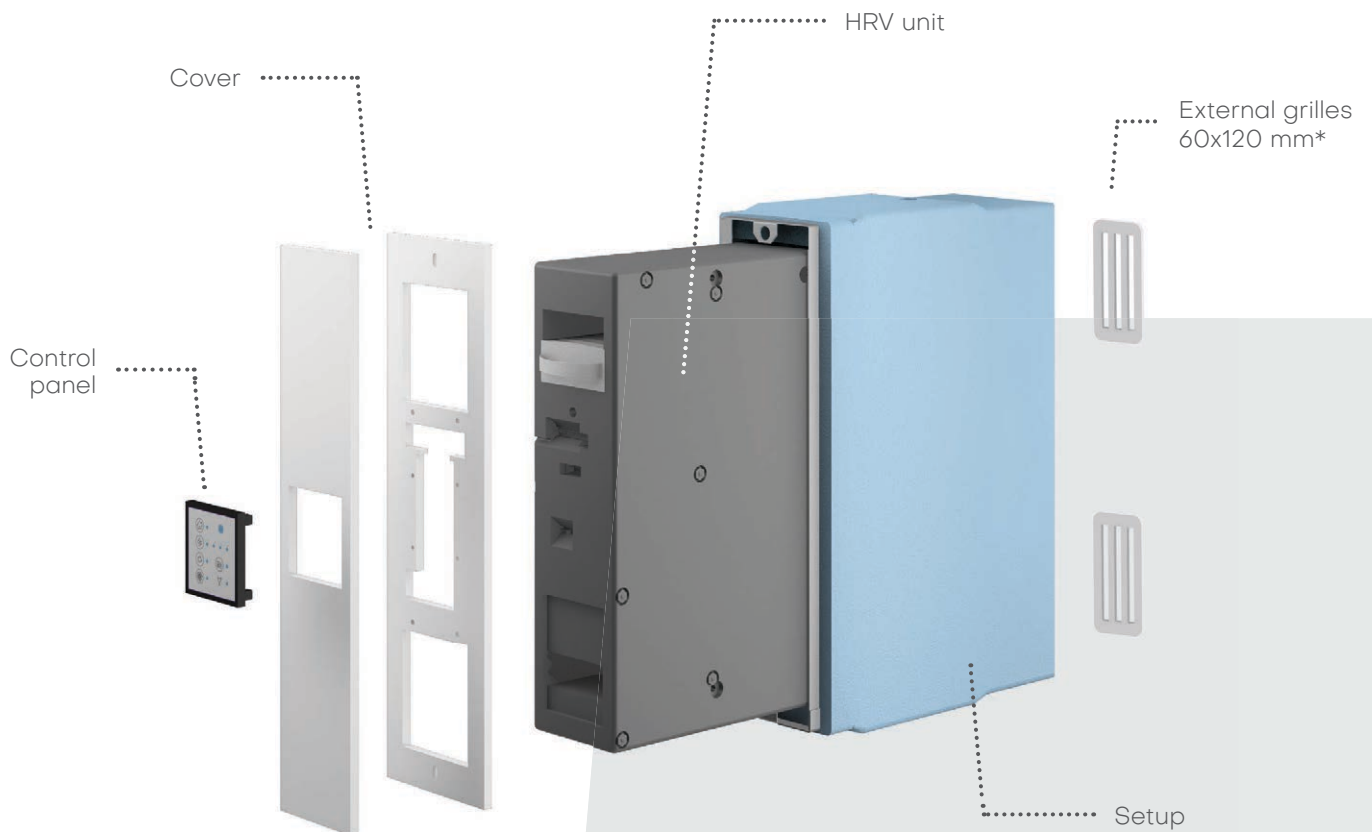

.....

Preparatory core drilling details and dimensions for Flow40 setup

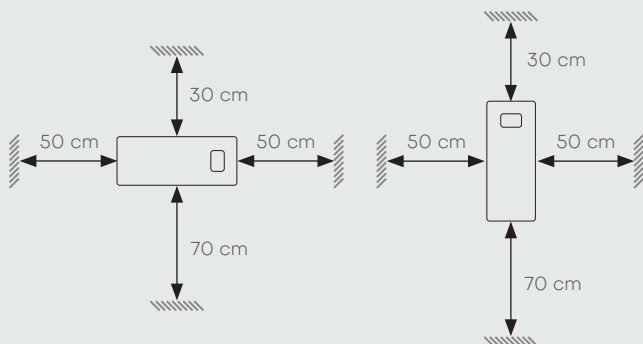
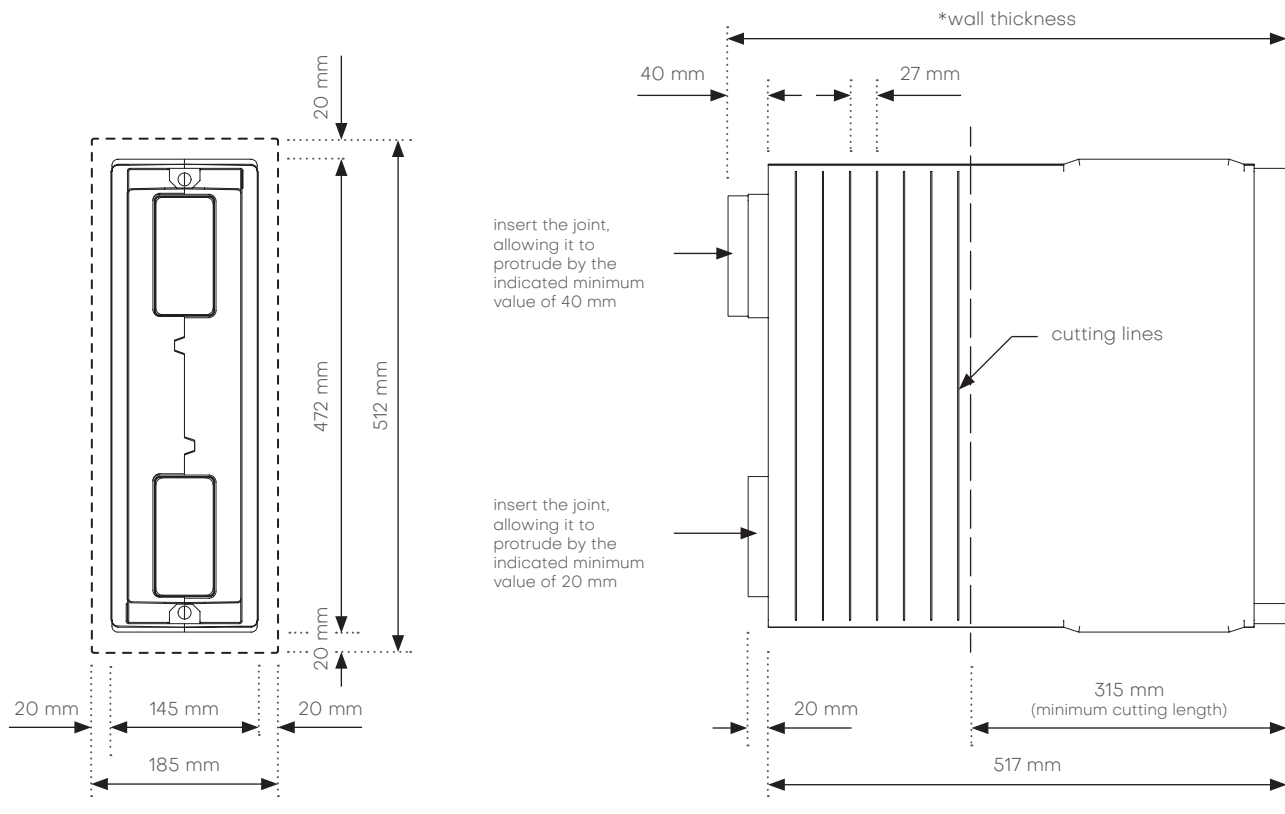

Recommended minimum orientation and dimensions

	UoM	Horizontal	Vertical
Above	cm	30	30
Below	cm	70	70
Left	cm	50	50
Right	cm	50	50

Masonry hole measurements

Position	UoM	Masonry hole W x H
Horizontal	mm	512 x 185
Vertical	mm	185 x 512

Wall thickness limits*

Wall thickness	UoM	Plaster	Cladding
Minimum	mm	335	355
Maximum	mm	535	555

Preparatory core drilling details and dimensions for Flow120/C120 setup

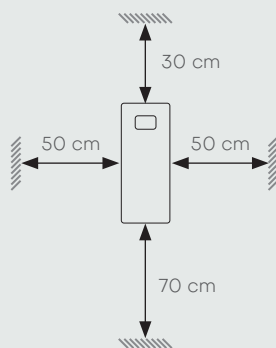
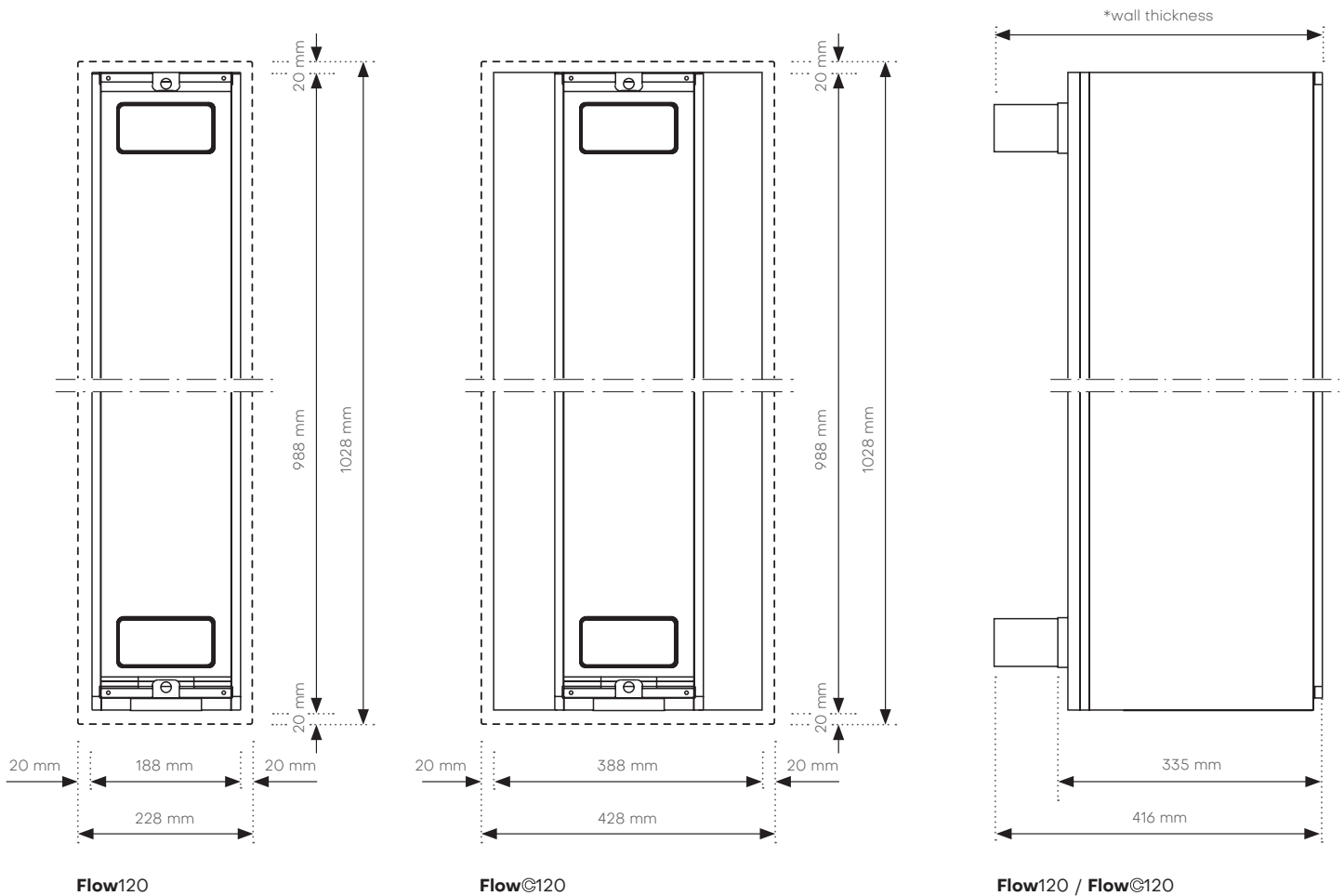

Recommended minimum orientation and dimensions

	UoM	Vertical
Above	cm	30
Below	cm	70
Left	cm	50
Right	cm	50

Masonry hole measurements

Model	UoM	Masonry hole W x H
Flow120	mm	228 x 1028
FlowC120	mm	428 x 1028

Wall thickness limits*

Wall thickness	UoM	Plaster	Cladding
Minimum	mm	345	365
Maximum	mm	416	416

Comparative analysis of HRV systems

The design of NZEB structures and the energy requalification of the existing building heritage confirm HRV devices as **an indispensable element in the options related to the air conditioning and healthiness of buildings**. Energy sustainability goals cannot ignore the economic sustainability of investments, i.e. a **comparative approach aimed at defining the overall cost of a plant solution**, taking into account not only the initial purchase price but also the costs to be incurred for maintenance and use throughout the life of the system.

An analysis by AI studio

A technical and economic comparative analysis was carried out comparing the **decentralised point-wise HRV** system with the two main alternative types of HRV on the market: **centralised ventilation** and **autonomous ducted ventilation**.

The assessment was prepared by **AI Studio**, a leading design firm specialised in consulting, management and implementation of sustainability standards in buildings.

The study outlines the characteristics of the HRV systems considered by examining their technical aspects – system architecture, air ducts, filtration, regulation systems, acoustic aspects, system maintenance – and economic aspects in the case of **different types of buildings: two-roomed apartments, three-roomed apartments, small villas and multi-occupancy buildings up to 64 units**.

The assessments were carried out for a "typical floor" and, within the standard floor, for the 4 individual apartments of which it is composed. In order to give representativeness to the assessment, the analysis was carried out by considering the climate data of four cities with **different climates: Bolzano, Milan, Rome and Palermo**.

Centralised system HRV

A ventilation unit with heat recovery, generally located on the roof, for several housing units with air distribution and extraction networks, each connected to its own fan.

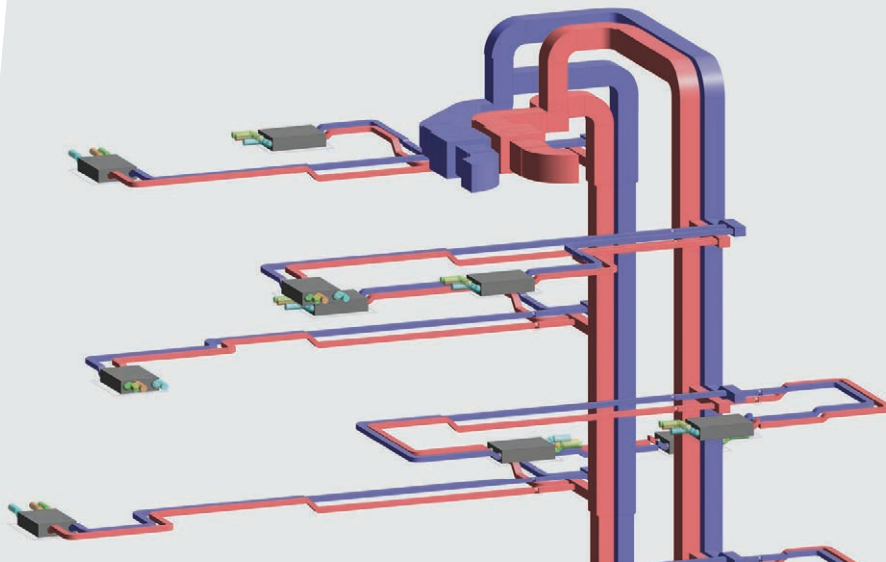
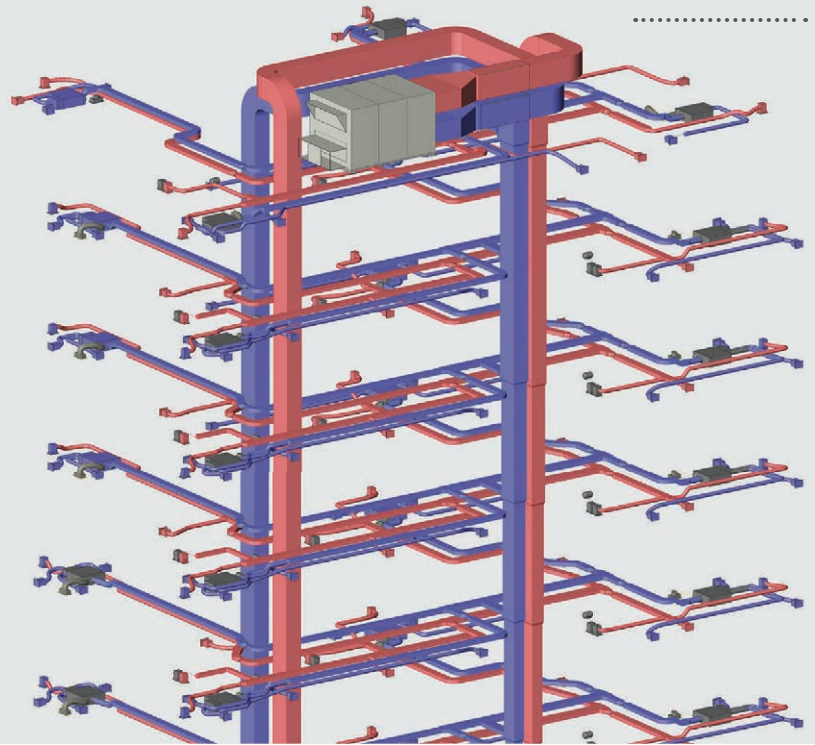

Autonomous ducted system HRV

One ventilation unit with heat recovery for each housing unit, with dual air network for supply and extraction.

Decentralised point-wise system HRV

A dual-flow point-wise ventilation unit for each room with heat recovery and air filtration, without air ducts.



.....

Comparison parameters and results

For each of the three types of controlled mechanical ventilation, the system was simulated in terms of materials and manpower required for its implementation and appliances with similar overall air flow rates, filtration levels and energy recovery efficiency performance were chosen for the purposes of homogeneity of comparison.

The economic indicators considered are:

- // **construction cost** (plant and structural works for both common areas and individual unit of saleable surface area per shaft);
- // **running cost** (electrical and thermal energy for ventilation; maintenance, including extraordinary charges);
- // **NPV -- Net Present Value** (calculated on 5 and 10 years of plant life).

The data analysed show that in each of the situations taken into consideration the decentralised point-wise HRV solution is the one that achieves **significant savings both in initial plant construction costs** - where the decentralised point-wise HRV is respectively -39% and -67% more competitive than centralised and autonomous ducted systems - **and in running and maintenance costs**, where the decentralised point-wise solution is on average -20% to -26% more competitive than centralised and autonomous ducted HRV solutions.

Evaluation of initial construction costs

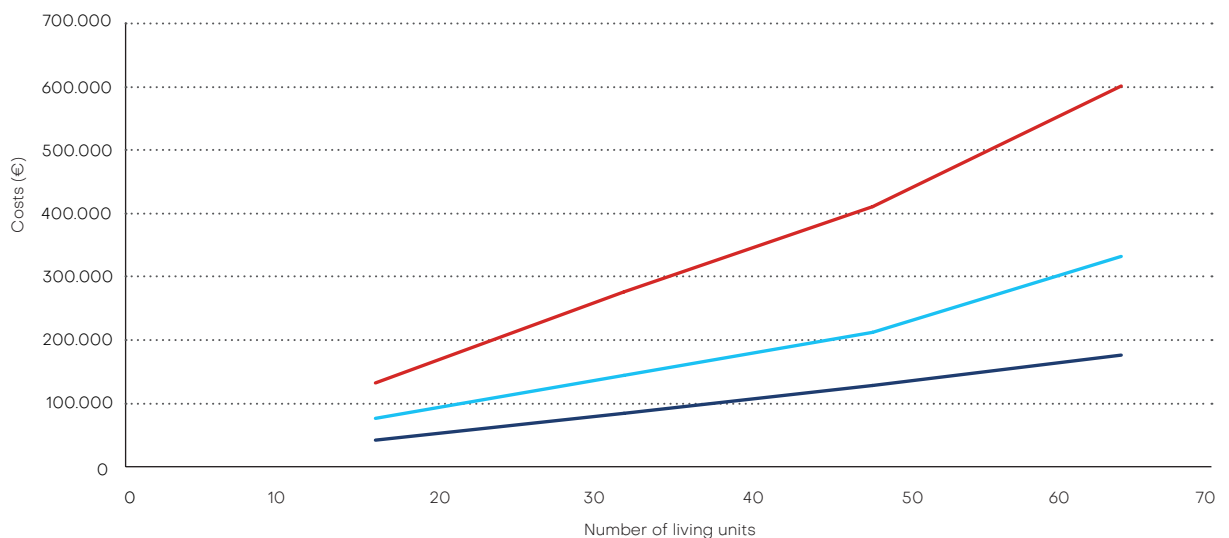

— Helyt Flow40 HRV — Autonomous HRV — Centralised HRV

Graphic representation of initial costs for the various types of HRV and building size. These values do not depend on the installation site's climatic factors.

Running costs

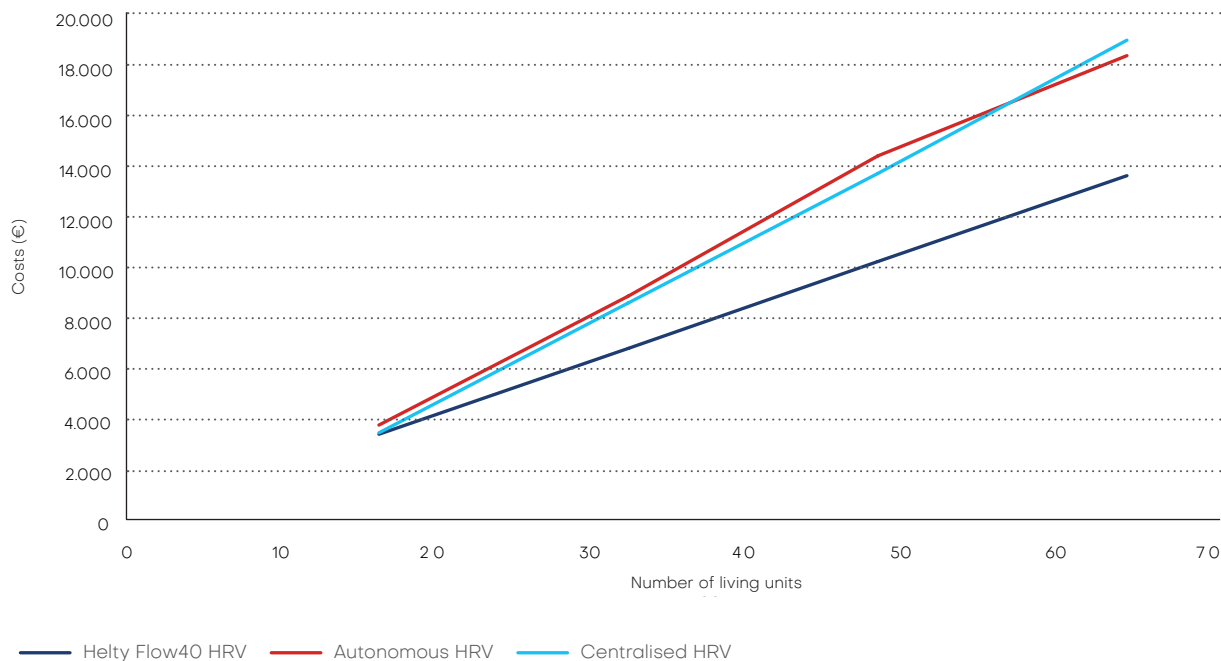

Graphical representation of the running costs of the various types of HRV depending on building size (referred to Milan).

The possibility of **smart ventilation with a “room-by-room” approach and only when needed**, i.e. based on actual air exchange needs in the individual rooms of a building and its usage profile, also goes in the direction specified by EU Directive 2018/844, which introduced the concept of “Smartness Indicator”. Adapting systems to the actual purpose of individual rooms is an advantage when ensuring proper ventilation yet avoiding unnecessary energy waste.

Frame the QR Code and download the comparative analysis of HRV systems



Wall recessed HRV

.....

Flow40

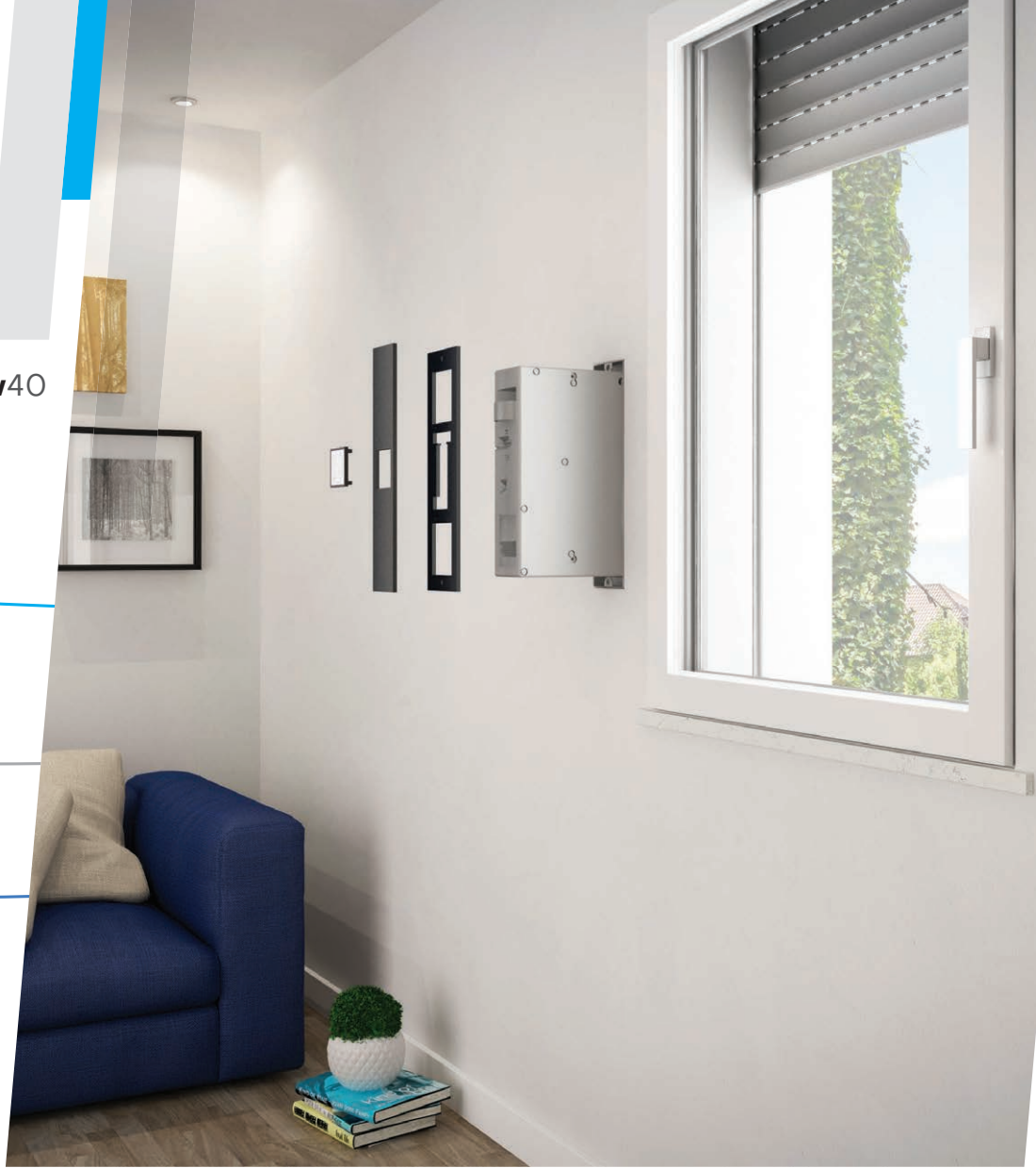

Flow120



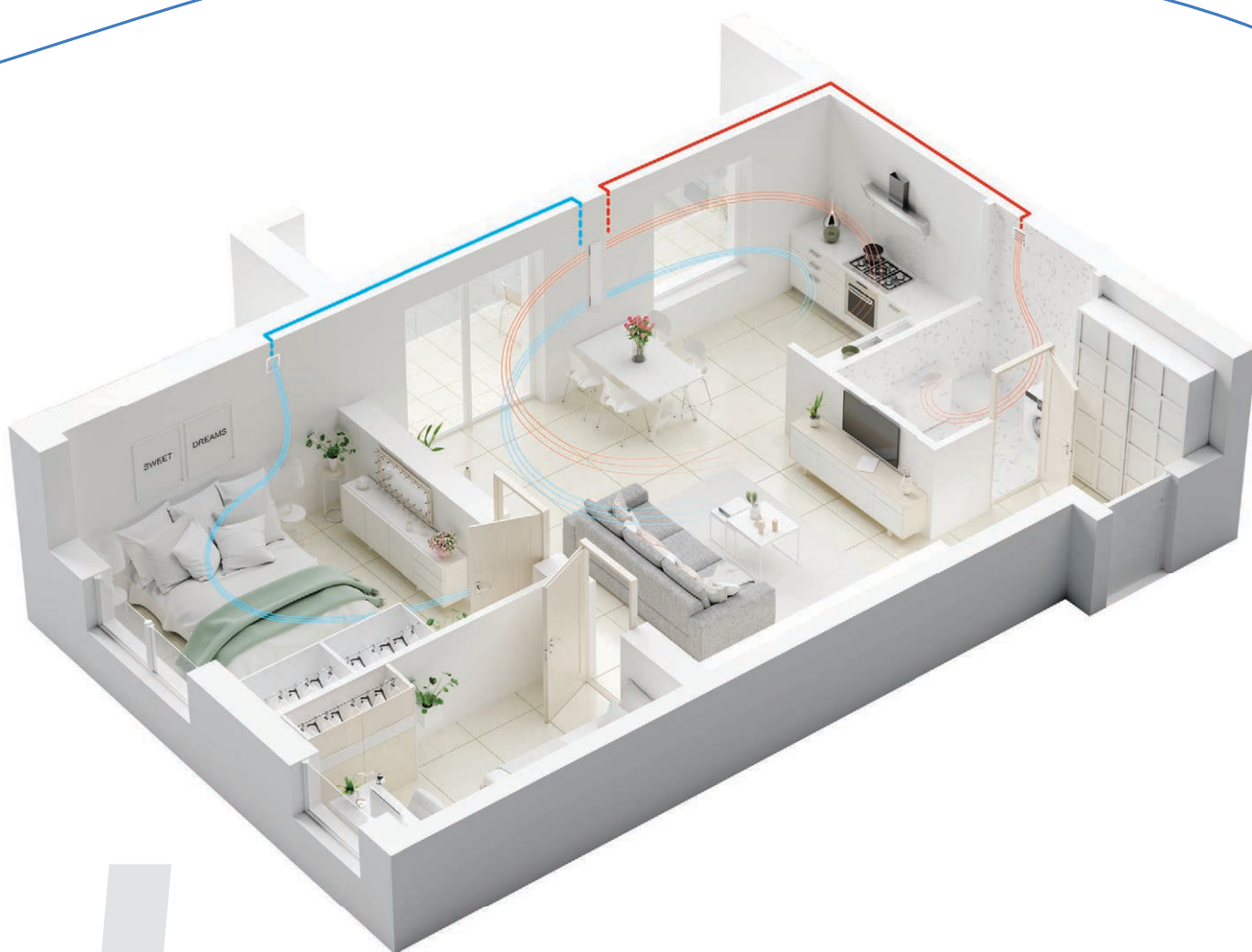

Flow©120

Example scheme of a HRV system on a three-room apartment managed with the Flow©120 ducted wall recessed system. Air supply and return can be partitioned off to other rooms adjacent to the room in which the built-in unit is installed.

.....

HRV for redevelopment

Patented HRV system installed in the outer wall insulation, without impacting the facade



Model

FlowMANHATTAN

Versions	STD	Plus	Elite
Night function	✓	✓	✓
Hyperventilation	✓	✓	✓
Filter replacement alert	✓	✓	✓
Free Cooling	✓	✓	✓
On/Off panel LED	✓	✓	✓
Remote control	✓	✓	✓
Humidity sensor	-	✓	✓
CO ₂ and VOC sensor	-	-	✓
Air Guard App	available with wall control panel	available with wall control panel	available with wall control panel





Flow MANHATTAN®



*A revolutionary point-wise HRV installed
“under the skin” in the wall insulation*

Flow Manhattan reinvents point-wise ventilation for individual environments, offering designers and buyers a solution in which **the HRV unit is camouflaged in the external wall insulation.**

The air flow grilles, fixed to the face of the window hole edge, are designed to protect the architectural profile of the building and **do not visually impact the facade at all. The internal impact is also minimal,** thanks to a diffuser with a particularly compact design. The supply and extraction air flows, separated by a special septum, pass through a **single 160 mm duct.** The formwork, fixed to the external masonry simultaneously with the installation of the wall

insulation layer, also allows only the **setup of the HRV system,** which can be completed in the next phase with the ventilation unit. The dual-flow HRV unit extracts stale air from the indoor environment and injects **new, oxygenated and clean air thanks to the special F7+G1 filters fitted** as standard. The ventilation speeds are variable according to the needs with **a maximum flow rate of 70 m³/h.** The enthalpy heat exchanger makes it possible to **recover up to 70% of the heat of the outgoing air by pre-heating the fresh air flow.**



*Standard, Plus and
Elite versions*

The most accessorised models integrate an on-board hygrometric sensor, CO₂ and VOC sensor for monitoring important indoor air quality parameters, control via remote wall panel and Air Guard Wi-Fi app.

A completely outdoor solution, which has minimal impact on the design of the house and guarantees the highest levels of acoustic comfort

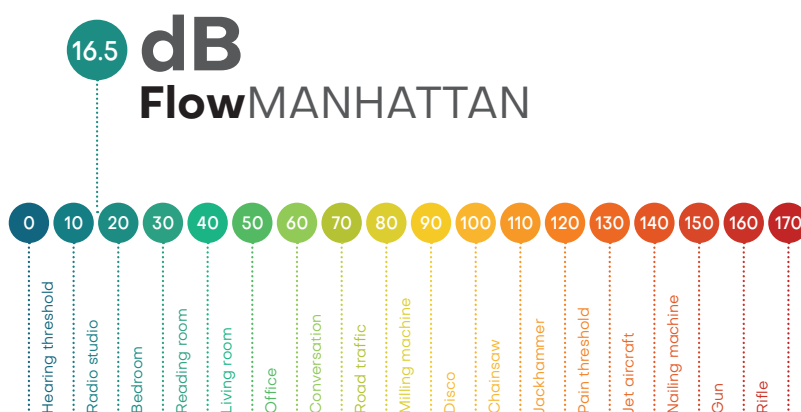

By placing the HRV unit in the outermost perimeter OF masonry, inside the insulation layer, Hely FlowMANHATTAN ensures **sound performance for optimal acoustic comfort**, with a sound pressure of 16.5 dB at minimum speed.



HRV for redevelopment

.....

Installation fully from the outside when laying the insulating layer.

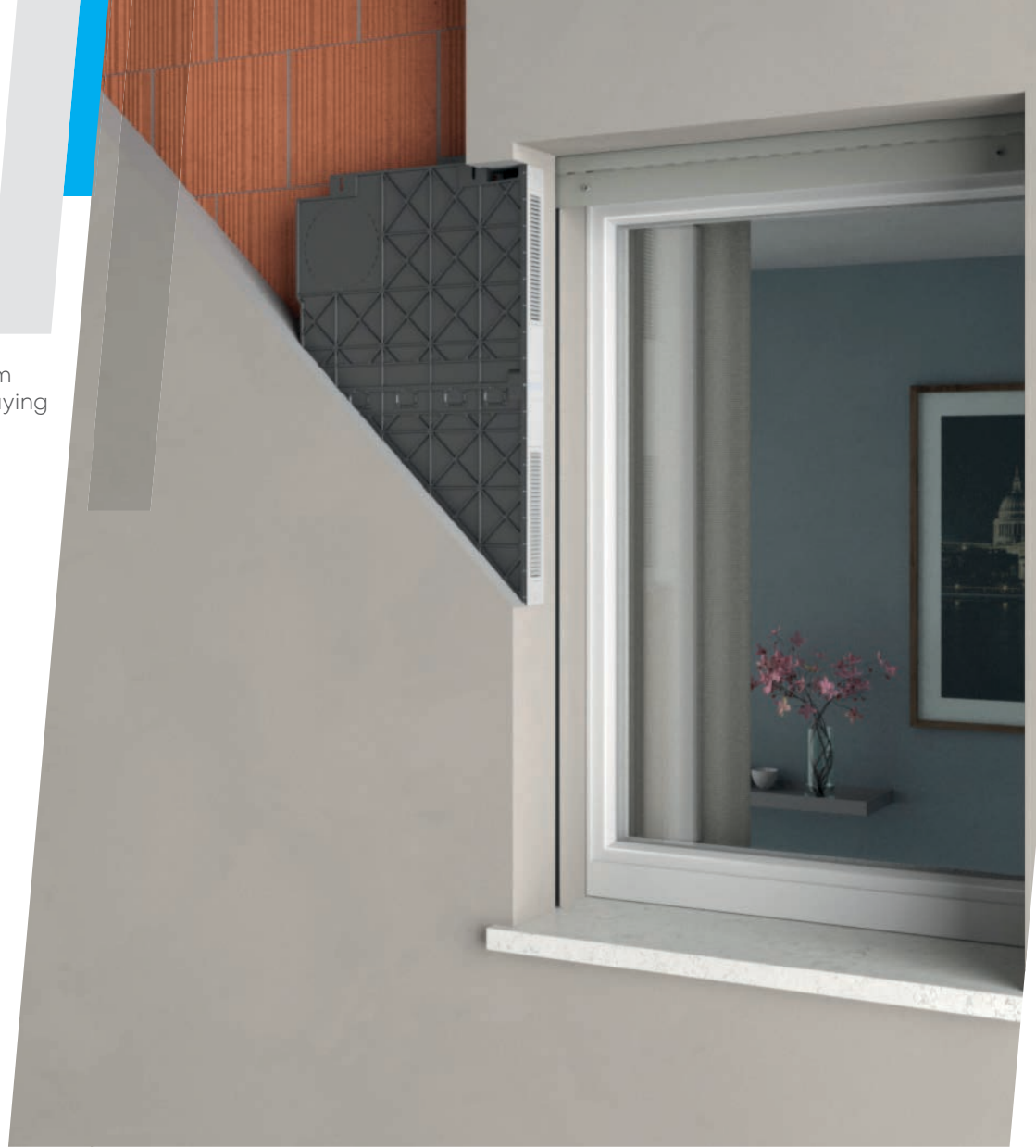

Zero impact on the facade and minimal impact on the interior.

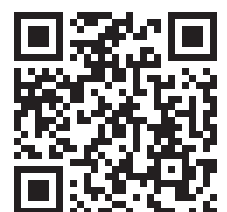

Frame the QR code
watch the video

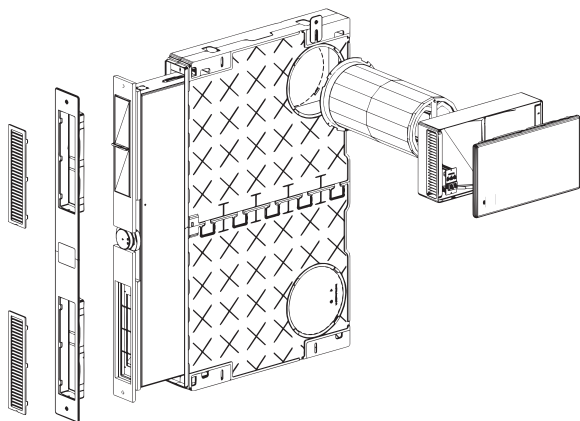

Sensors for automatic humidity, CO₂ and VOC management.



Remote control panel for controlling the unit and setting functions.



Thanks to the supplied infrared remote control, it is easy to operate from anywhere in the room.



70%

Heat recovery efficiency



16.5 dB(A)

Sound pressure



70 m³/h

Maximum air flow



F7

Air intake filtration



-35.4 kWh/m²a

SEC energy consumption (temperate climate)

Technical data

Energy efficiency class **A**

Specifications	UoM	Value
Air flow rate	m ³ /h	20/25/30/40/50/70 ⁽¹⁾
Flow adjustment		night + 4 stages + hyperventilation
Power consumption (excluding heater)	W	5/6/7/9.5/13/34 ⁽¹⁾
Specific power (excluding heater)	W/m ³ /h	0.25/0.24/0.23/0.24/0.26/0.49 ⁽¹⁾
Power supply voltage	V AC	230
Operating voltage ⁽²⁾	V DC	24
Max. current consumption ⁽³⁾	A	0.35
HRV unit weight	kg	7
Unit dimensions (vertical W x H x D)	mm	460 x 740 x 65
Setup dimensions (vertical W x H x D)	mm	510 x 830 x 80
Internal diffuser dimensions (L x H x D)	mm	325 x 185 x 85
Core-drilled hole	mm	1x Ø160
Heat exchanger		enthalpy cross-flow
Heat recovery efficiency	%	70
Sound power level ⁽⁴⁾	dB(A)	28/31/36/43/48/56 ⁽¹⁾
Sound pressure ⁽⁵⁾	dB(A)	16.5/19.5/24.5/31.5/36.5/44.5 ⁽¹⁾
Facade noise abatement Dn, e, w	dB	51
Filters (intake / extraction)		F7 / G1
Modbus RTU rs485		Yes ⁽⁶⁾
Energy efficiency class (cold / temperate / hot)		A+/A/E
SEC (cold / temperate / hot)	kWh/m ² a	-67.7/-35.4/-14.3
Unit type		UVR-B bidirectional
Specific Power Input SPI ⁽⁷⁾	W/(m ³ /h)	0.24

1. In hyperventilation mode
2. The use of the supplied power supply allows power to be supplied at 230 V AC. To be connected during installation.

3. With 230 V AC supply voltage
4. According to UNI 3744:2010
5. Measured in a 30 m² semi-anechoic environment at a distance f 3 m

6. This excludes control via the panel interface
7. In accordance with EN 13141-8:2014-09

Community HRV

Systems for air exchange
in medium and large rooms



Model	Flow600		Flow800		Flow1000	
	STD	Pure	STD	Pure	STD	Pure
Version						
HRV unit only	-	-	✓	✓	✓	✓
Steel	✓	✓	✓	✓	-	-
Silent (wooden cover)	-	-	✓	✓	✓	✓
M (wooden cabinet)	-	-	✓	✓	✓	✓
Functions / accessories						
Night function	✓	✓	✓	✓	✓	✓
Hyperventilation	✓	✓	✓	✓	✓	✓
Filter replacement alert	✓	✓	✓	✓	✓	✓
Humidity sensor	-	✓	-	✓	-	✓
On/Off panel LED	✓	✓	✓	✓	✓	✓
Free Cooling	✓	✓	✓	✓	✓	✓
CO ₂ and VOC sensor	-	✓	-	✓	-	✓
Remote control panel*	option	✓	option	✓	option	✓
Web App HCloud	option	option	option	option	option	option
Ioniser kit	option	option	option	option	option	option
Heater kit	option	option	option	option	option	option

* Allows use of the Air Guard app





Flow600

*Slim shape,
versatile performance*

Flow600 Steel is one of the **“new entries” in the revamped Community 2023 HRV range** for installations in hospitality spaces, offices, schools and kindergartens. Flow 600 Steel allows modulation of the air exchange on **variable flow rates between 250 m³/h (minimum speed) and 600 m³/h (maximum speed in hyperventilation)**, with four intermediate flow rates to flexibly meet design needs requiring high air exchange rates in medium to highly crowded environments such as classrooms.

The unit is equipped with a cross-flow enthalpy heat exchanger, which allows **heat recovery efficiency of up to 82%** and does not require the setup of any condensate drain.

It ensures excellent filtration levels thanks to the G3+F9 filter group fitted as standard. The HRV unit is natively **integrated in a white painted steel cover**, complete with air intake and extraction openings, which allows the unit to be installed exposed, avoiding the need for additional cladding. It can be **installed on the ceiling or also as a vertical wall-mounted version** by means of a special conduit casing, which **allows the intake/extraction sockets to be managed on either the right or left side**, so as to adapt to design requirements. **Two 200-mm core-drilled holes** in the external wall, or alternatively four 100-mm holes, are sufficient.

IAQ sensors in the Pure version

In addition to the standard version, Flow600 Steel is also available in Pure version with hygrometric sensor and CO₂ and VOC sensor for monitoring essential occupant well-being parameters such as relative humidity, carbon dioxide levels and volatile organic compounds. By detecting the values in real time, **the HRV can automatically adjust the air exchange according to the actual needs** read in the room to be ventilated.



82%

Heat recovery efficiency



35 dB(A)

Sound pressure



600 m³/h

Maximum air flow



G3+F9

Air intake filtration

Versions

Energy efficiency class **A**

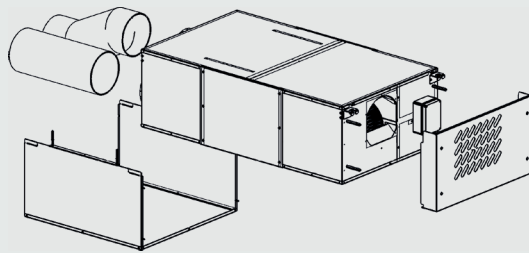

Flow600^{Steel}
Ceiling installation

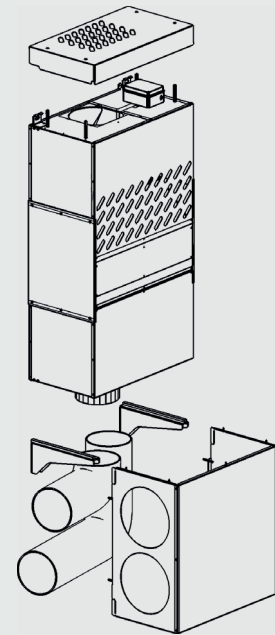

Flow600^{Steel}
Wall installation





Flow800

High air exchange without compromising aesthetics and acoustics



Frame the QR Code and watch the case histories

Performing and silent, Flow800 is renewed and expands the family with new versions to better meet and satisfy the needs of designers and commissioners. Alongside the HRV unit alone, ideal for positioning in rooms with false ceilings, the range offers new versions: Flow800 **Steel**, where the HRV is natively integrated in a white painted steel cover for exposed installations, manageable either on the ceiling or on the wall; **Flow800 Silent**, completed by an aesthetic cover in white wood, for ceiling installations that require to **minimise the aesthetic and acoustic impact of the HRV**; **FlowM800**, where the ventilation unit is made totally invisible by camouflaging

it on a white cabinet that offers ease of integration in rooms and great simplicity of access to the unit for inspections and filter changes. The air flow can be modulated over 6 values, **from 300 m³/h** (minimum speed in night mode) up **to 800 m³/h** (maximum speed in hyperventilation), by means of the panel that offers the intuitive control interface used in Helyt systems. A control panel for built-in installation in 503 electrical boxes is also available as an accessory. The enthalpy heat exchanger ensures **80% heat exchange efficiency**, while the **G3+F9 dual filter** stops approximately 90% of PM10 and 80% of PM2.5 by bringing oxygenated and purified air inside.

Superior well-being with air quality sensors

In addition to the standard version, all Flow800 models are **available in Pure version with hygrometric sensor and CO₂ and VOC sensor**. By monitoring parameters such as relative humidity, carbon dioxide levels and volatile organic compounds in each room, the HRV allows automatic and intelligent regulation of air exchange to ensure maximum well-being in each class.



80%

Heat recovery efficiency



21.5 dB(A)

Sound pressure (Silent version)



800 m³/h

Maximum air flow



G3+F9

Air intake filtration

Versions

Energy efficiency class **A**

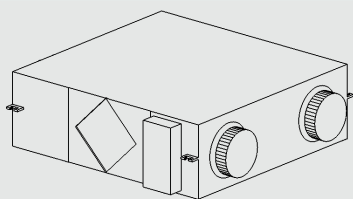

Flow800

HRV unit

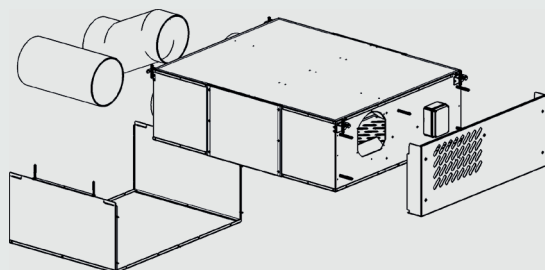

Flow800^{Steel}

Ceiling installation

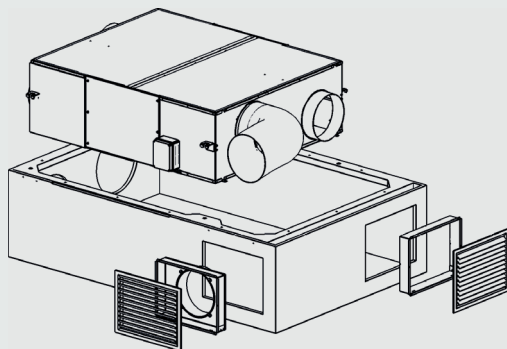

Flow800^{Silent}

HRV with wooden cover for ceiling installation

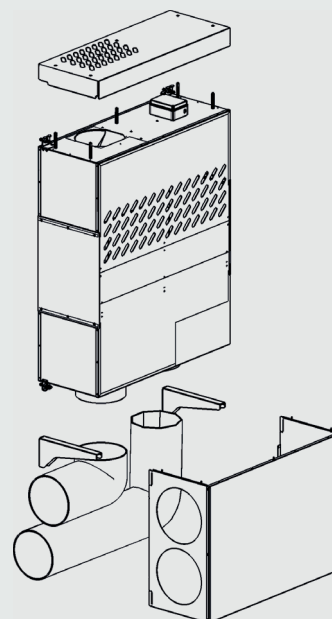

Flow800^{Steel}

Wall installation

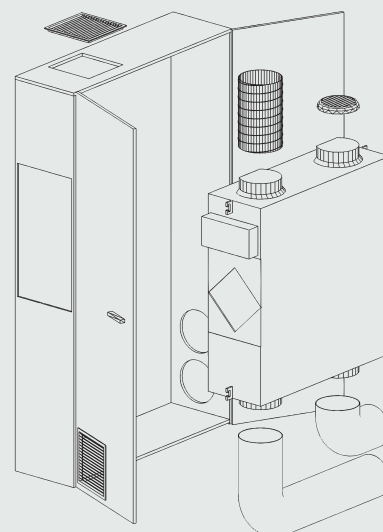

FlowM800

HRV on wooden cabinet

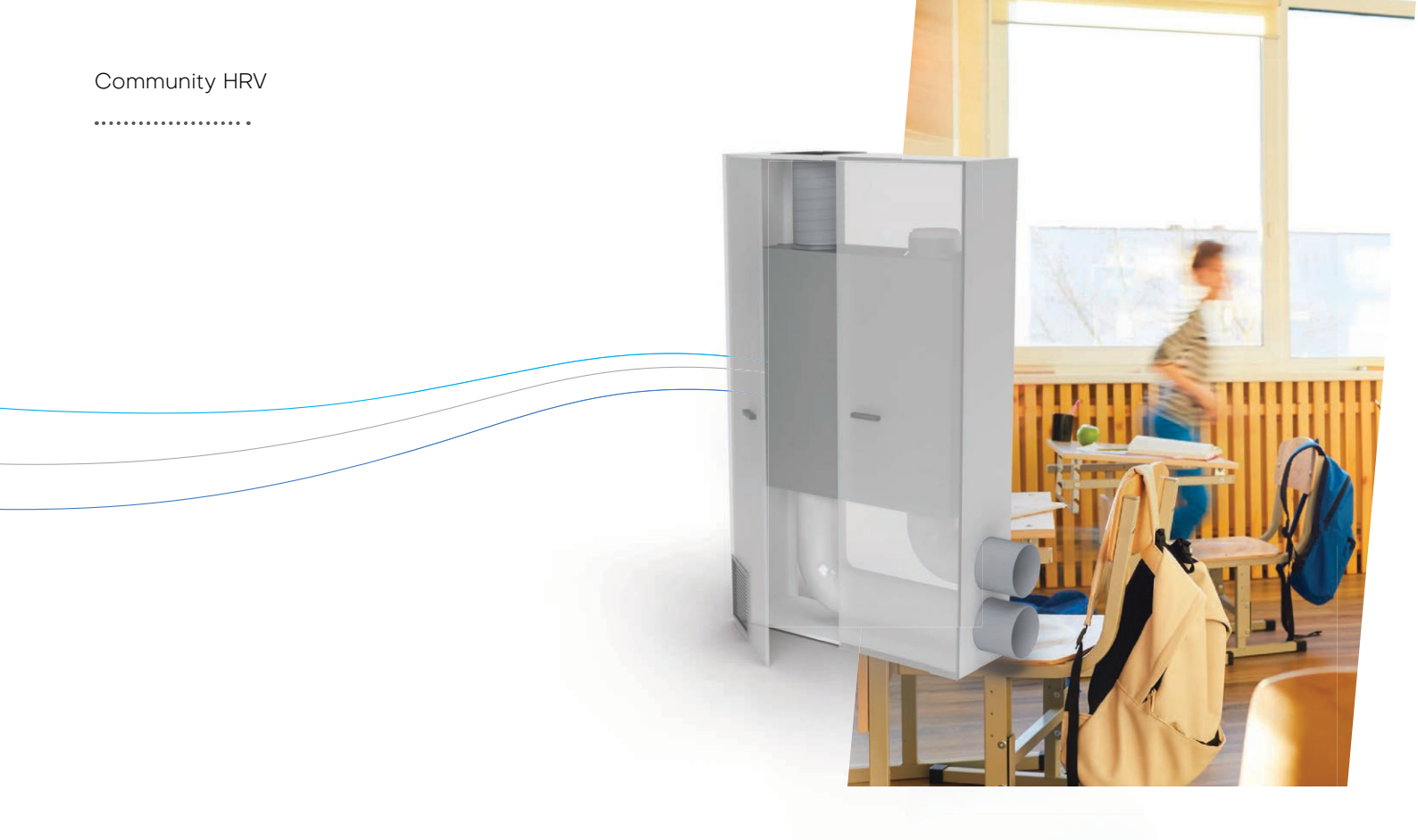

Flow1000

Top decentralised ventilation for retrofitting existing buildings

Flow1000, the latest addition to the HRV Community family, was created to meet the need for optimal air exchange in all those **very crowded spaces** – such as classrooms, kindergartens, recreational spaces, shared offices, co-working spaces, shops, canteens – where it is essential to have high air quality without sacrificing comfort and energy saving. With **variable air flow of up to 1000 m³/h**, it is ideal for integrating a decentralised HRV system into existing buildings without resorting to complex and invasive masonry work, and minimising ductwork and installation time. Flow1000 is available as **HRV unit only**, as well as in the versions **Flow1000 Silent**

– with an aesthetic white painted wooden cover for ceiling installation – and **FlowM1000** – with a white wooden vertical cabinet structure.

80% heat recovery efficiency, excellent air purification capabilities thanks to G3+F9 filters, and **easy maintenance** make it the ideal solution for an uncompromising HRV retrofitting. The installation requires two 250 mm core-drilled holes in the external wall to manage the air intake and extraction flows; it can also be managed with 4 x 125 mm conduits using accessories. A **MOD-BUS output is standard for controlling the machine directly from home automation systems.**

Additional sanitisation with ionisation

To enhance the indoor air purification action, the Flow1000 Silent and M1000 versions can accommodate an energy-efficient active sanitising device that generates **bipolar ions**, developed to provide naturally existing air quality to confined indoor environments. **The combined action of air dilution, filtration and sanitisation** reduces the risks of airborne distribution of microbial, bacterial and viral loads.



80%

Heat recovery efficiency



21.5 dB(A)

Sound pressure (Silent version)



1000 m³/h

Maximum air flow



G3+F9

Air intake filtration

Versions

Energy efficiency class **A**

Flow1000
HRV unit

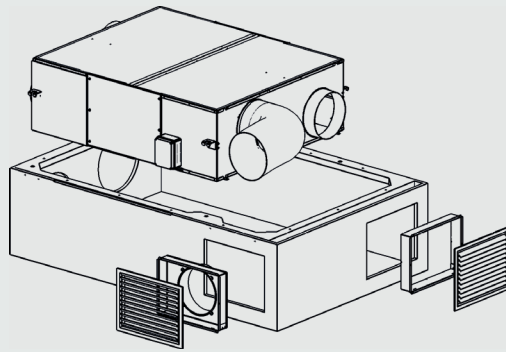
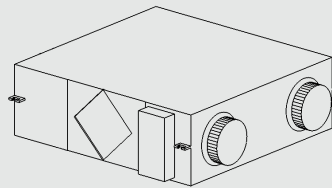

Flow1000 Silent
HRV with wooden cover for ceiling installation

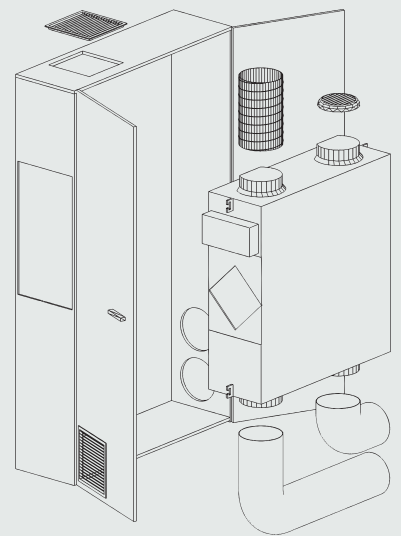

FlowM1000
HRV on wooden cabinet



Technical data

Specifications	UoM	Flow600 ^{Steel}	Flow800 ^{Steel}	Flow800 ^{Silent}
Air flow rate	m ³ /h	250/300/350/450/550/600	300/350/500/600/700/800	300/350/500/600/700/800
Flow adjustment		night + 4 stages + hypervent.	night + 4 stages + hypervent.	night + 4 stages + hypervent.
Power consumption	W	30/44/60/94/166/220	22/26/46/61/90/138	22/26/46/61/90/138
Power supply voltage	V AC	230	230	230
Operating voltage ⁽¹⁾	V DC	24	24	24
Max. current consumption ⁽²⁾	A	1	0.7	0.7
HRV unit weight	kg	55	75	73
Wooden cover weight	kg	-	-	60
FlowM cabinet weight	kg	-	-	-
HRV unit dimensions (W x H x D)	mm	1374 x 395 x 706	1374 x 395 x 1020	1320 x 392 x 1020
Wooden cover dimensions (W x H x D)	mm	-	-	1797 x 475 x 1213
FlowM cabinet dimensions (W x H x D)	mm	-	-	-
Core-drilled holes	mm	2x Ø200 / 4x Ø100	2x Ø250 / 4x Ø125	2x Ø250 / 4x Ø125
Heat exchanger		enthalpy cross-flow	enthalpy cross-flow	enthalpy cross-flow
Heat recovery efficiency	%	82	80	80
Bypass (Freecooling/Freeheating)		electronic manual	electronic manual	electronic manual
Sound power level ⁽³⁾	dB(A)	50/53/57/61/67/69	43.5/46.2/54.9/56.9/59.4/64.4	37.2/39.7/46.7/53.3/57.7/58.7
Sound pressure ⁽⁵⁾	dB(A)	35/39/43/47.4/52.5/55	28.6/31.3/40/42/44.5/49.5	21.5/24/31/37.6/42/43
Filters (intake / extraction)		G3+F9 / G3	G3+F9 / G3	G3+F9 / G3
Modbus RTU rs485		Yes ⁽⁴⁾	Yes ⁽⁴⁾	Yes ⁽⁴⁾
Energy efficiency class (cold / temperate / hot)		A+ / A / E	A+ / A / E	A+ / A / E
SEC ⁽⁶⁾ (cold / temperate / hot)	kWh/m ² a	-76.8 / -40.6 / -17.2	-77.1 / -41.3 / -18.1	-77.1 / -41.3 / -18.1
Unit type		UVNR-B bidirectional	UVNR-B bidirectional	UVNR-B bidirectional
Filter energy performance ⁽⁷⁾		A+	A+	A+
SFPint ⁽⁷⁾	W/(m ³ /s)	771	626	621
Specific Power Input SPI	W/(m ³ /h)	0.17	0.09	0.09

1. The use of the supplied power supply allows power to be supplied at 230 V AC. To be connected during installation
 2. With 230 V AC supply voltage
 3. According to UNI 3744:2010

4. This excludes control via the panel interface
 5. Measured at 1 m below the machine, corrected with background noise and reverberation time
 6. EN 13141-8:2014-09

7. According to EU Regulation No. 1253/2014

Energy efficiency class **A**

FlowM800	Flow1000 ^{Silent}	FlowM1000
300/350/500/600/700/800	300/400/550/700/850/1000	300/400/550/700/850/1000
night + 4 stages + hypervent.	night + 4 stages + hypervent.	night + 4 stages + hypervent.
22/26/46/61/90/138	25/44/77/130/210/320	25/44/77/130/210/320
230	230	230
24	24	24
0.7	1.7	1.7
73	73	73
-	60	-
93	-	93
1320 x 392 x 1020	1320 x 392 x 1020	1320 x 392 x 1020
-	1797 x 475 x 1213	-
1236 x 2400 x 450	-	1236 x 2400 x 450
2x Ø250 / 4x Ø125	2x Ø250 / 4x Ø125	2x Ø250 / 4x Ø125
enthalpy cross-flow	enthalpy cross-flow	enthalpy cross-flow
80	80	80
electronic manual	electronic manual	electronic manual
37.2/39.7/46.7/53.3/57.7/58.7	37.2/41.7/48.7/57.7/59.2/60.7	37.2/41.7/48.7/57.7/59.2/60.7
21.5/24/31/37.6/42/43	21.5/26/33/42/43.5/45	21.5/26/33/42/43.5/45
G3+F9 / G3	G3+F9 / G3	G3+F9 / G3
Yes ⁽⁴⁾	Yes ⁽⁴⁾	Yes ⁽⁴⁾
A+ / A / E	A+ / A / E	A+ / A / E
-77.1 / -41.3 / -18.1	-77.1 / -41.3 / -18.1	-77.1 / -41.3 / -18.1
UVNR-B bidirectional	UVNR-B bidirectional	UVNR-B bidirectional
A+	A+	A+
621	1153	1153
0.09	0.14	0.14

Ventilation and risk reduction in indoor environments

Indoor spaces are contaminated by a broad spectrum of biological pollutants, including plant pollen and spores, bacteria, fungi, algae and a number of protozoa species. Their presence can be linked to excessive humidity and inadequate ventilation. Indoor air pollution by chemical, physical, and biological agents **affects the respiratory system, causes allergies and asthma, immune system disorders, and damages cardiovascular and nervous systems**, exposed skin, and mucous membranes.



Primary air quality deterioration factors

Human activities indoors also produce **CO₂**; **when present in excess, it causes drowsiness** (at times, pupils at their school desks appear lazy because of insufficient air exchange in the classroom). According to a study published by the universities of Harvard and Syracuse **in the Environmental Health Perspectives journal, cognitive performance decreases with rising ambient CO₂ levels**. Abilities to use information, to respond to crises and to develop strategies are particularly affected.



And now, **having to live with COVID-19** requires even more to rethink and redesign indoor areas where people can crowd in confined spaces. **Ensuring effective air exchange and purified air in school classrooms, kindergartens, hotels, offices, bars and restaurants, cinemas and theatres** is essential to counteract infection risks. **Bioaerosol particles (droplets) of less than 10 microns** produced by simply breathing, talking, singing, coughing or sneezing can circulate in the air for hours in enclosed spaces lacking adequate air exchange. If such droplets are emitted by positive, yet asymptomatic, individuals, they can be inhaled by others and cause infection (this applies to COVID-19 but also to ordinary seasonal influenza). In addition to health risks linked to the possible spread of pathogens, **air quality also deteriorates due to factors such as particulates, VOCs and possible underground radon gas emissions.**

The significance of proper indoor air exchange management has recently been emphasized by the WHO (World Health Organization) through the publication of a "Roadmap for Enhancing and Ensuring Good Indoor Ventilation" in the context of Covid-19. Besides, the "Recommendations of the **UNESCO Chair on Health Education and Sustainable Development**", issued in 2020, identify the correlation between academic performance and air quality in classrooms. However, natural ventilation by opening windows has several disadvantages: opening windows for at least 5 minutes every hour means letting in air that is very cold in winter or very hot in summer, unnecessarily dissipating energy expended for ambient heating or cooling. Furthermore, opening windows does not hinder smog, pollen and allergens that make indoor air unhealthy.

The positive effects of HRV in classrooms and offices

- // A comfortable micro-climate, with stable temperature and properly controlled humidity, contributes to physical well-being and improves learning.
- // The reduction of excess CO₂ avoids drowsiness, fatigue and headaches, improving concentration and attention.
- // The dispersal and extraction of volatile organic compounds, particulates and biological pollutants (moulds) reduces the risks of allergies and respiratory problems.

HCloud

HRV control, software updates,
IAQ data monitoring.
Everything remotely thanks to
the new WebApp



HCloud is Hely's new web-based platform that allows the **operating status and settings** of individual HRV Community units to be managed and controlled at all times, facilitating timely **remote check and technical support** when needed.

The app, created with a full-managed approach, i.e. able to check and monitor the status of machines and initiate software updates, can be reached at **hcloud.heltyair.com** and is accessible to **different user profiles**: Technical Support Center.

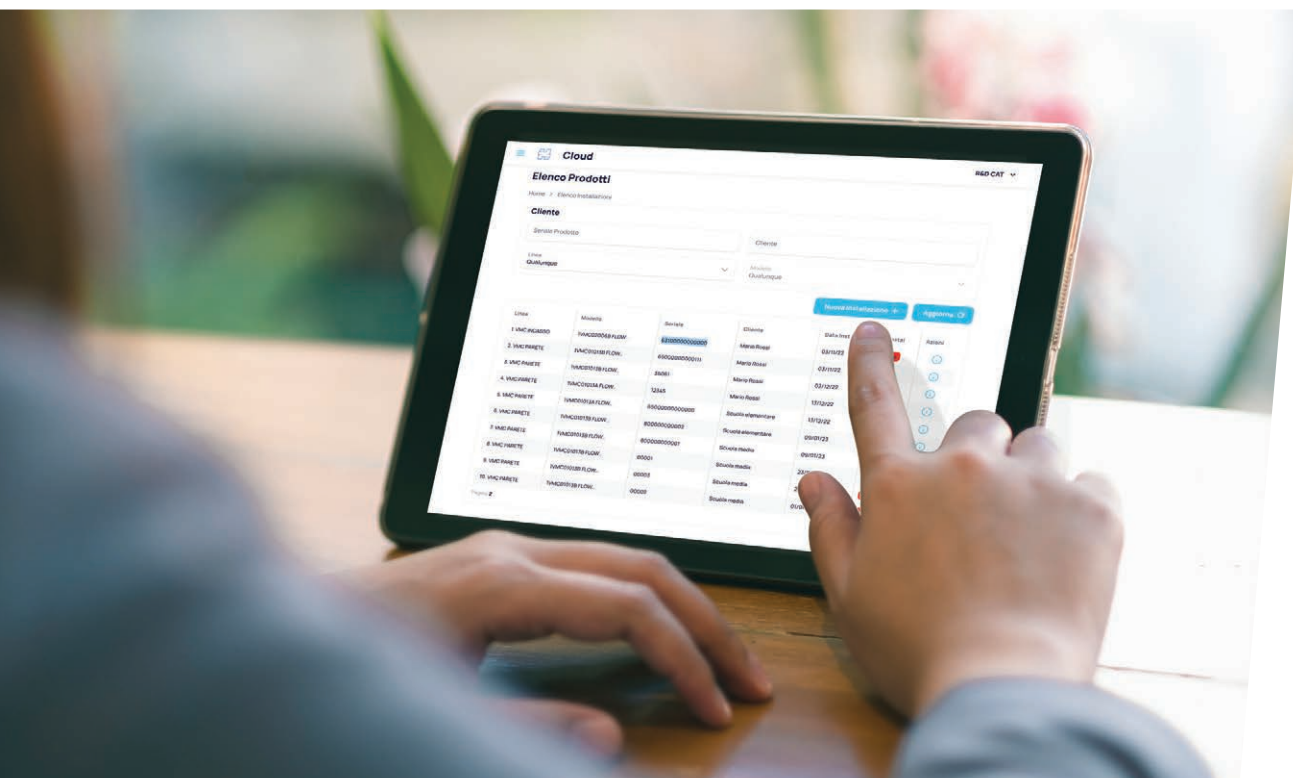

Real-time parameters

Thanks to the **continuous on-site data collection** of microclimate parameters (temperature, humidity) and indoor pollutants (CO₂ and VOC) in the rooms served by the ventilation units, HCloud allows **real-time monitoring of the status of the main parameters affecting air health** and a **historicised reading of IAQ data trends** in the rooms.

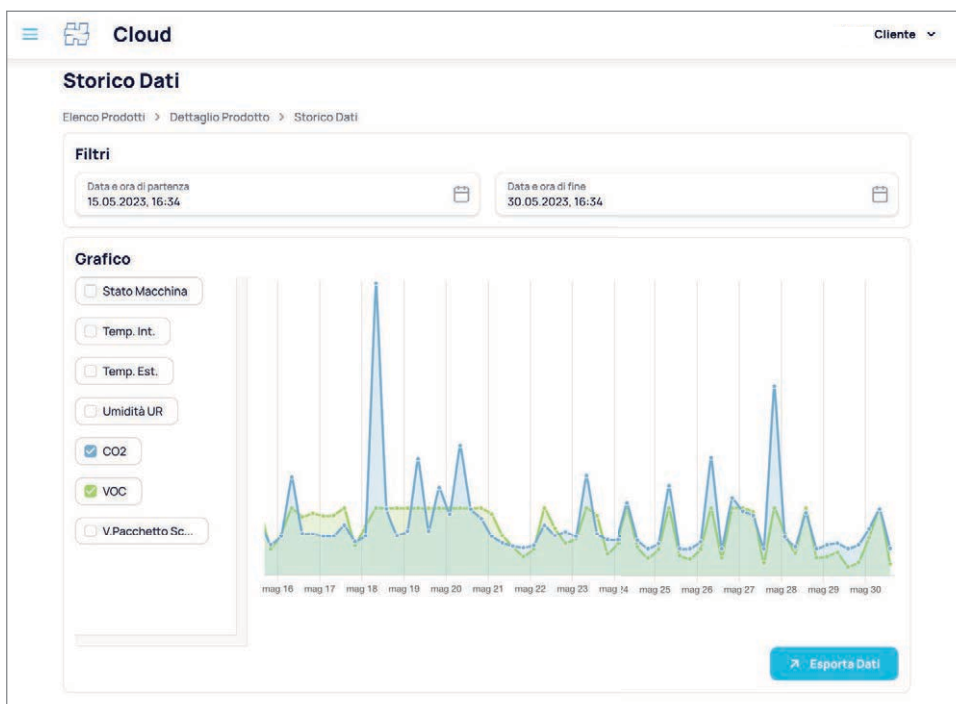

Through HCloud, it is also possible to **create and set pre-configured scenarios** such as the start-up or shut-down of the HRV system or specific air flow rates on specific days and time slots, so as to optimise the operation of the ventilation unit according to the air exchange and comfort needs of the room while limiting the required energy consumption to a minimum.

// The platform will be **available from September 2023**, initially only **for HRV Community Helty systems** equipped with the appropriate optional control.

Control panel

Maximum user-friendliness



Pos.	Description
A	Timer On/Off ⁽¹⁾ and LED dimmer ⁽²⁾
B	Ventilation adjustment
b	Fan speed LED
C	Night mode
D	Hyperventilation
d	Hyperventilation function LED
e	Filter replacement alert LED
F	Free Cooling ⁽³⁾
f	Free cooling function LED

1. Available on FlowEASY
 2. Available on FlowELITE
 3. Available for all models except FlowEASY

A Wi-Fi control panel suitable for a 503 electrical box, compatible with the main electrical plates, is available for FlowMANHATTAN and all Flow community models.

Functions



On/Off Timer and LED dimmer

Activates the automatic switch-off timer function⁽¹⁾. It enables you to turn on the LEDs and adjust their intensity⁽²⁾.



Ventilation adjustment

Enables to set the 4 different ventilation speeds according to the user preferences.



Night mode

Sets the HRV to a minimum ventilation speed and reduces the brightness of the LEDs, providing continuous and silent air exchange and ensuring quality sleep. Keeping the button pressed long deactivates the LEDs.



Hyperventilation

Air flow is boosted to the maximum for faster air exchange and forced room ventilation for short periods.



Free Cooling/Free Heating

An intelligent technology that provides natural indoor cooling: if the external air has a temperature lower than inside, the HRV stops the heat recovery function before air is introduced into the room, thus maintaining optimal thermal conditions. Thus, naturally fresh air is conveyed indoors to create a natural air conditioning effect. This technology is particularly beneficial during summer nights and mid-seasons when outdoor temperatures are more agreeable. Conversely, with Free Heating you can take advantage of the warmer external air during mid-seasons or warm winter days.



Filter replacement alert

This warns you when it is time to replace the filter to safeguard the unit performance.

.....

App Air Guard

For smart management!



The Hely Air Guard Smart App is designed for the integrated management of Hely Controlled Mechanical Ventilation systems, with the **option of differentiating air exchange management in each room**. The system is compatible with smartphones and tablets,

for maximum comfort in just one touch. The user-friendly interface makes using the Hely Smart App easy and intuitive and **provides information on indoor air quality**, indicating the measured values of humidity, temperature, VOC and CO₂*

Download Hely App

The Hely Air Guard App is available on the Apple Store for IOS operating system devices and on the Google Play Store for Android users.



No internet connection is needed (only to download the App); it works within the perimeter of the home.

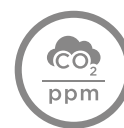

It indicates air quality data: humidity, temperature, VOC and CO₂*



It enables all HRVs to be controlled simultaneously.

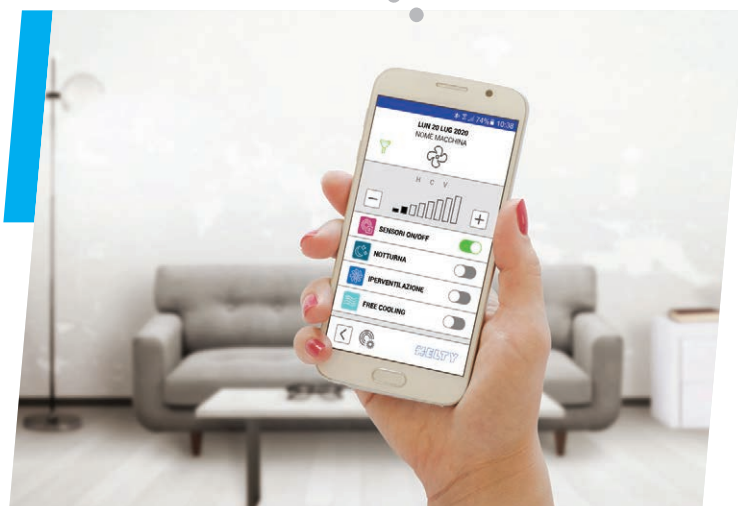

*if the HRV units are equipped with sensors

Filters and spare parts

Helty Flow non-ducted systems make filter change as easy as possible

The user only has to **replace the air filter**, conveniently indicated by the LED on the device or by the app, and then **reset the filter alarm**. For all wall-mounted, wall recessed and cabinet HRV systems, this operation, which is necessary on average every 6 to 12 months, can be managed in full autonomy in a few minutes and does not require external service personnel.



Point-wise HRV: design tips

Healthy HRV systems adapt to any environment. The range includes a number of differentiated solutions specifically designed for new buildings, major renovations and non-invasive redevelopment works.



One-room apartment

Surface (s): 26 m²

Volume (v): 26x2.7 = 70.2 m³

Air exchange requirements* (R): $R = v/2 = 35.1 \text{ m}^3/\text{h}$

Suggested installation:

1 HRV device

(+ 1 optional extractor for the bathroom)



*requirements may change according to national regulation

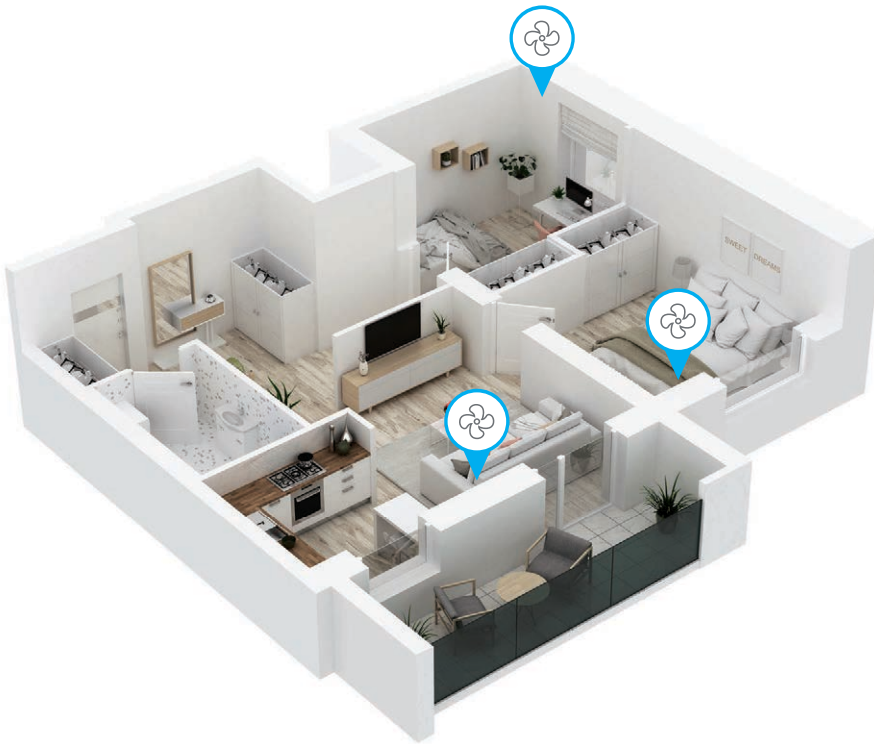

Two-room apartment

Surface (s): 48 m²
 Volume (v): 48x2.7 = 129,6 m³
 Air exchange requirements* (R):
 $R = v/2 = 64.8 \text{ m}^3/\text{h}$

Suggested installation:
 3 HRV devices
 (+ 1 optional extractor for the bathroom)

Three-room apartment

Surface (s): 96 m²
 Volume (v): 96x2.7 = 259,2 m³
 Air exchange requirements* (R): $R = v/2 = 129.6 \text{ m}^3/\text{h}$

Suggested installation:
 4 HRV devices
 (+ 2 optional extractors for bathrooms)

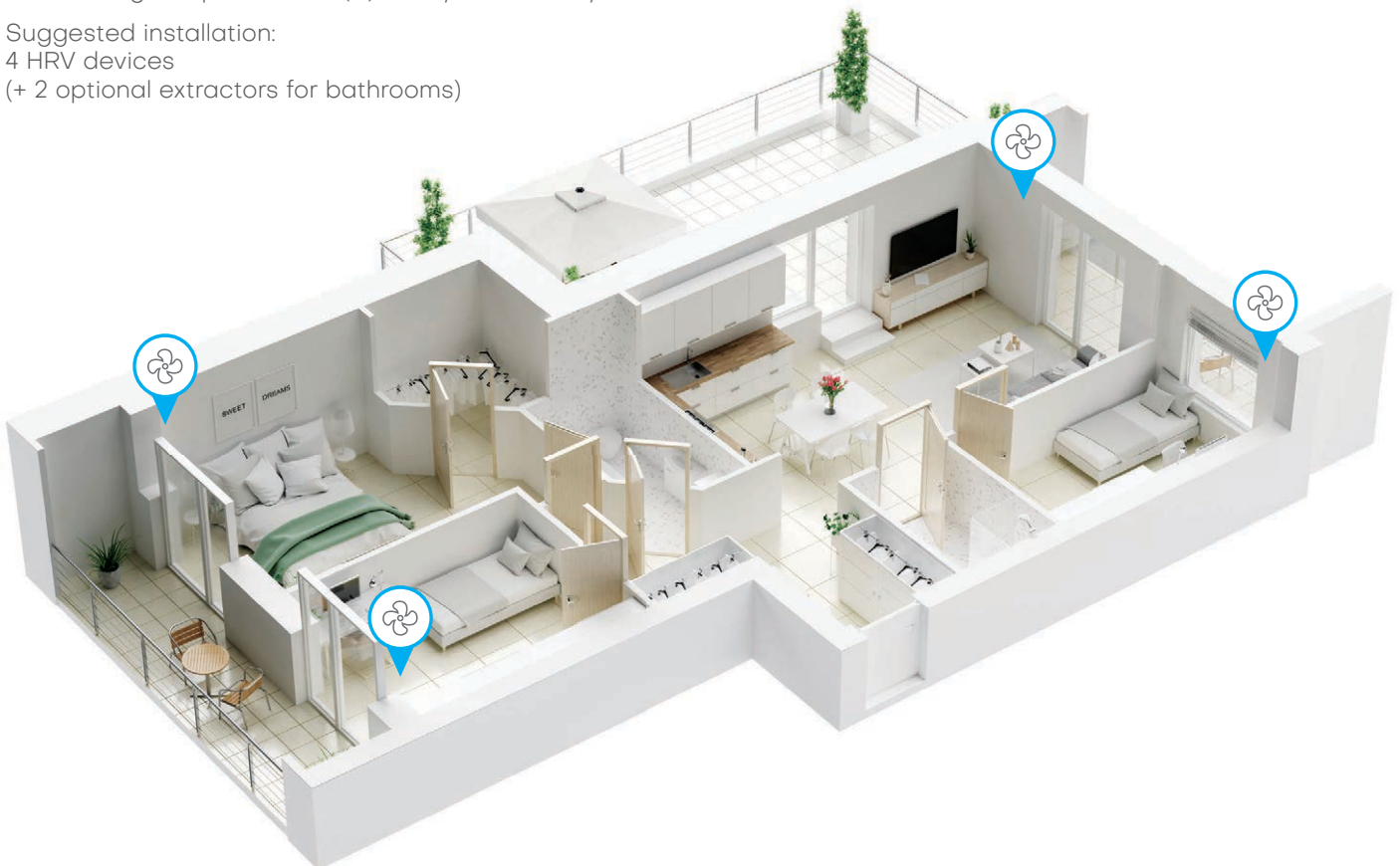

All Seasons: comfort systems

*Decentralised air/air reversible
heat pump with integrated HRV*



Version	Window-side output	Facade output
Hot-cold function	✓	✓
Dehumidification	✓	✓
Night function	✓	✓
Hyperventilation	✓	✓
Timetable	✓	✓
Filter replacement alert	✓	✓
LCD remote control touch panel	✓	✓
Free Cooling	✓	✓
App	✓	✓
Humidity sensor	✓	✓
TVOC, CO ₂ sensors	✓	✓
Paintable aesthetic covers	✓	✓



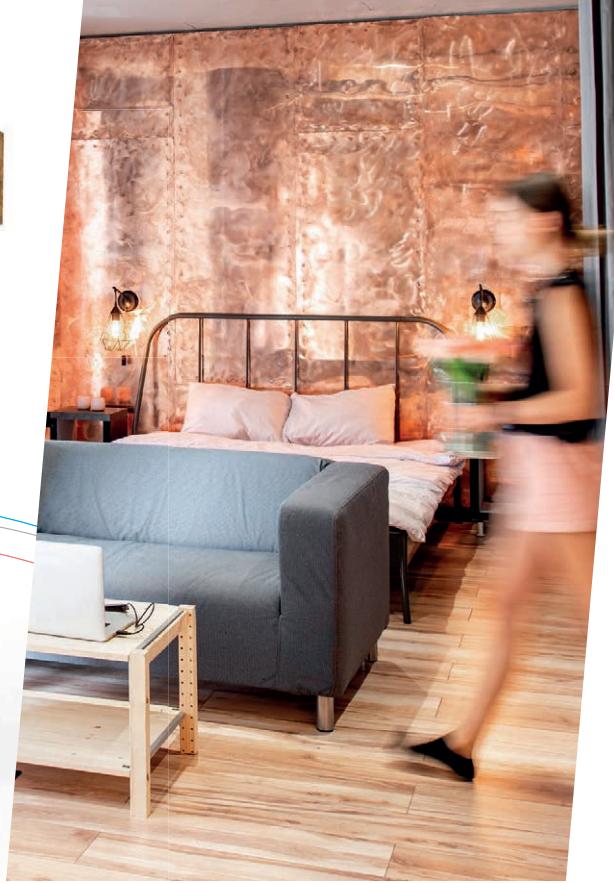

All Seasons



*Hot/cold and decentralised air exchange,
without external or internal units*

All Seasons is the innovative solution that meets the needs of modern buildings to achieve the best energy efficiency classes dictated by the **European EPBD Directive** (current Directive 2018/844/EU previously identified as 2010/31/EU: EPBD - Energy Performance Building Directive) by fully embracing the principle of the "Smart Readiness Indicator" and extensive use of renewable energy sources as expressed by the European RES Directive (current Directive 2018/2001/EU of the European Parliament and of the Council of 11 December 2018 on the promotion of the use of **energy from renewable sources** previously identified as Directive 2009/28/EU of the European Parliament

and of the Council of 23 April 2009). Specifically **designed for very high energy efficiency and NZEB** (Nearly Zero Energy Buildings), All Seasons is the complete, industrialised solution conceived to provide a **single system suitable for annual cycle air conditioning (heating, cooling and ventilation)** of residential buildings, small tertiary buildings, offices, hotels and all those applications where the management of thermo-hygrometric comfort and air quality on a **room-by-room** basis is important: where and when needed, following a decentralised and intelligent logic.

- // It minimises system footprint both inside and outside the building.
- // It eliminates water as a carrier fluid while maintaining "air-to-air" heat pump technology.
- // Independent HRV and A/C control: control of air quality and independent thermohygrometric comfort.

Air conditioning and air quality in an all-in-one solution

All Seasons is composed of a air diffusion unit and a trivalent unit for air conditioning and replenishment, connected to each other.

The air diffusion unit is positioned flush with the wall for the management of hot and cold air flows. Thanks

to its special shape, the air diffusion unit allows immission of both conditioned and replenished air. The trivalent unit with heat pump is based on DC inverter technology and equipped with an R32 refrigerant circuit, with embedded HRV (controlled

mechanical ventilation) unit equipped with air filtration and cross-flow heat exchanger.

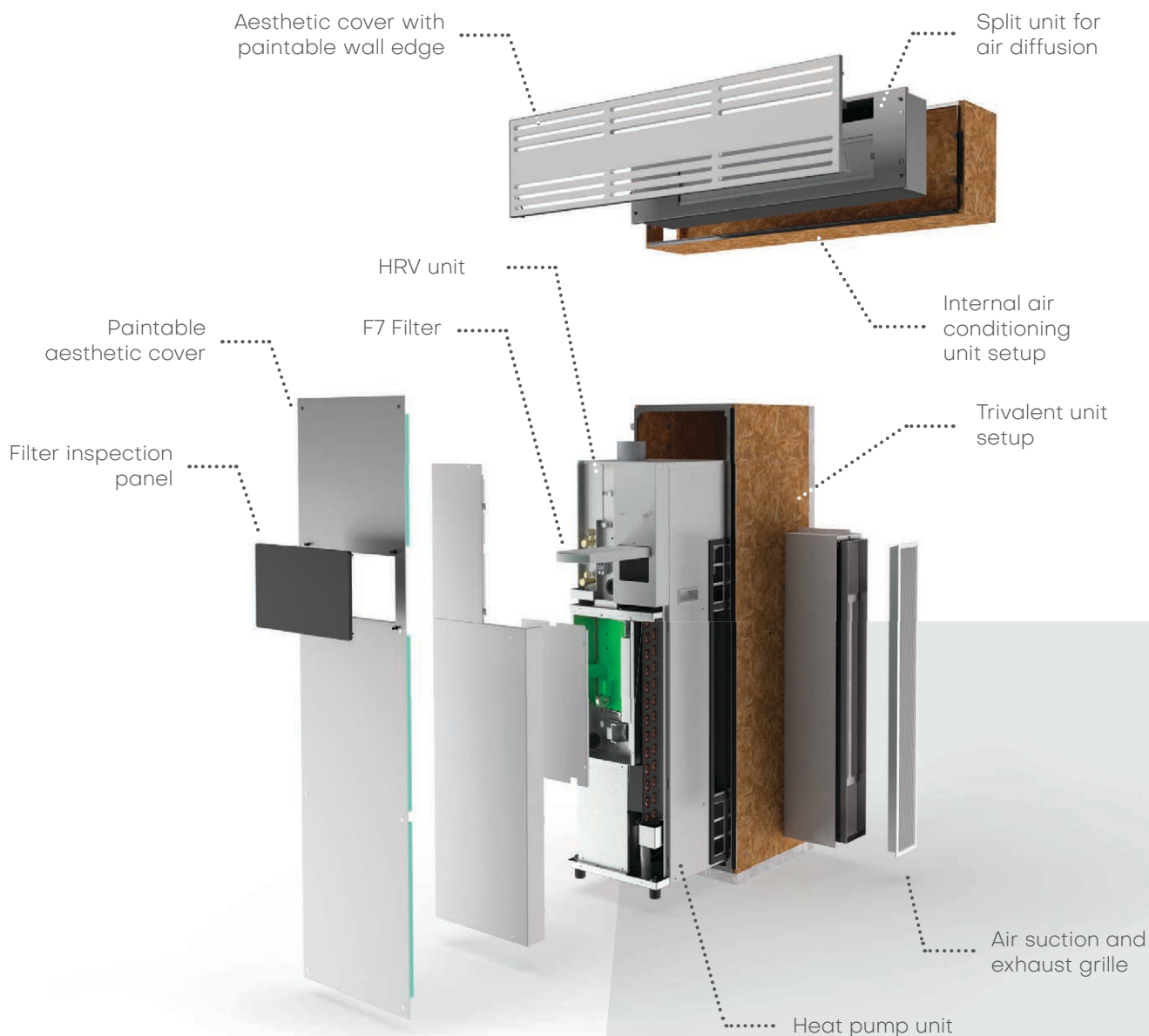

Comfort systems

.....

Interior view of version with window-side output



External view of version with window-side output

Building-plant
integration with
no impact on
architecture



No external unit



No internal unit

External view of version
with facade output



.....

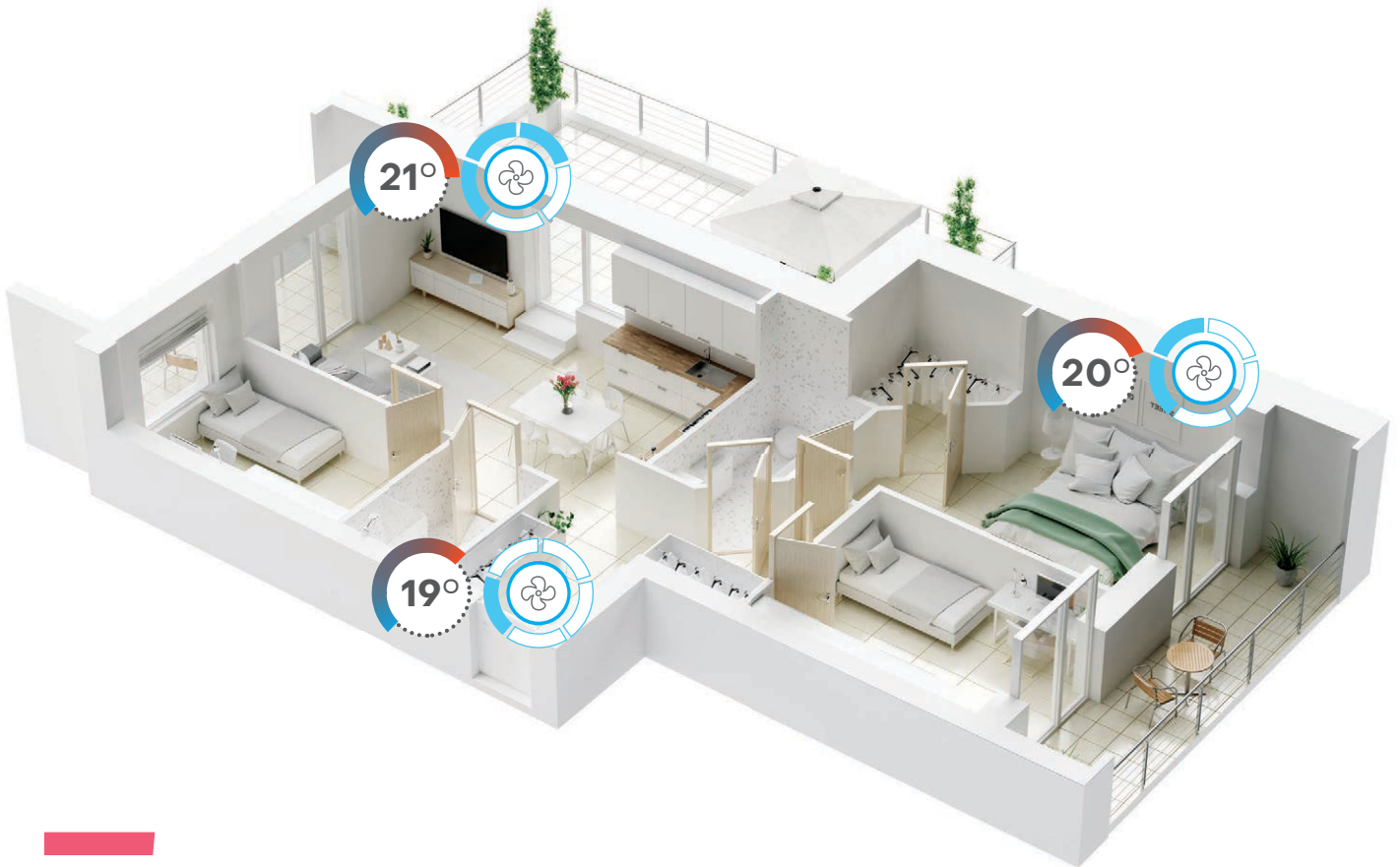

Warm, cold and air exchange: only where and when you need it

All Seasons is the complete solution providing **a single system suitable for managing winter heating, summer air conditioning and dehumidification** and indoor air quality, following a decentralised and intelligent logic:

- // NZEB residential buildings;
- // properties for tourist use and student residences;
- // small tertiary properties;
- // offices;
- // hotels & B&Bs;
- // prefabricated modular constructions.



Control panel

Intuitive and intelligent management



The remote panel with LCD touch screen allows for intuitive use and offers an up-to-date reading of indoor air quality values.

All Seasons systems can be conveniently managed remotely via the Smart Life mobile app, which is also useful for setting up integrated configurations with other IoT devices for smart home management.



Pos.	Description
1	All Seasons unit On/Off
2	Operating mode setting: Cooling, Heating, Ventilation, Dehumidification, Automatic
3	Function selection: Eco, Sleep, Turbo, Quiet
4	Air conditioner speed setting
5	Temperature setting
6	Function Status, De-ice, Wi-Fi, Alarms
7	Values: Indoor temperature, TVOC, Humidity, PM2.5, CO ₂
8	Enable/Disable Air Renewal (HRV)

More spaces for living, higher safety on installation

All Seasons by Helty represents an **industrialised solution that provides greater certainty in the control of the system lead time**, given the modularity with which the product can be used, and enables the intelligent and interconnected use of thermal and electrical renewable energies in line with the needs of modern construction. The built-in solution presented by All Seasons allows to maximize the "saleable" floor surface of buildings and, thanks to direct-expansion technology, it **considerably simplifies the system works required** and reduces ancillary construction costs.



Reference standards





The air conditioning units of the All Seasons series are designed and manufactured in accordance with the following directives and reference standards:

- // Directive 2014/30/EU Electromagnetic Compatibility (EMC);
- // Directive 2014/35/EU Low Voltage Directive (LVD);
- // Directive 2011/65/EU RoHSM;
- // Directive 2009/125/EC ErP and Regulation 2012/206/EC;
- // WEEE directive 2012/19/EU;
- // F-Gas Regulation 2014/517/EU;
- // EN 60335-2-40 Household and similar electrical appliances – Safety – Part 2: Particular requirements for electrical heat pumps, air-conditioners and dehumidifiers;
- // EN 13141-1 Ventilation for buildings – Part 1: Externally and internally mounted air transfer devices.

Air conditioning and purification solution for the SmartBoxx compact mobile office, in modular construction





.....

 1.8 kW Cooling capacity	 1.6 kW Heating capacity	 6.1 Seasonal energy efficiency ratio	 4 Seasonal coefficient of performance	 26.5 dB(A) Sound pressure ⁽⁵⁾
--	--	---	---	---

Air conditioning technical data

Energy efficiency class **A++** **A+**

	Specifications	UoM	Value
Summer Air Conditioning ⁽¹⁾	Energy efficiency class		A++
	Pdesign	W	1800
	SEER		6.1
	Yearly energy consumption	kWh/y	103
	Cooling capacity for air conditioning (min / nominal / max)	W	370/1800/2300
	Power consumption for air conditioning (nominal)	W	527
	EER Energy Efficiency (nominal)		3.42
Winter Air Conditioning ^(1,2)	Energy efficiency class		A+
	Pdesign	W	1600
	SCOP		4
	Yearly energy consumption	kWh/y	559
	Heating capacity for air conditioning (min / nominal / max)	W	465/1600/2900
	Power consumption for air conditioning (nominal)	W	408
	COP Energy Efficiency (nominal)		3.92
Sound pressure level L _{1c} ⁽³⁾	dB(A)	30	

 90 % Maximum thermal recovery efficiency	 70 m ³ /h Maximum air flow	 F7 Air intake filtration
---	--	---

HRV technical data

Energy efficiency class **A**

Specifications	UoM	Value
Air flow rate	m ³ /h	10/22/33/41/57/70 ⁽⁴⁾
Power consumption	W	3/4/7/9/16/23 ⁽⁴⁾
Heat exchanger		enthalpy
Energy efficiency class (cold / temperate / hot)		A+ / A / E
Heat recovery efficiency	%	90
Filters (intake / extraction)		F7 / G4

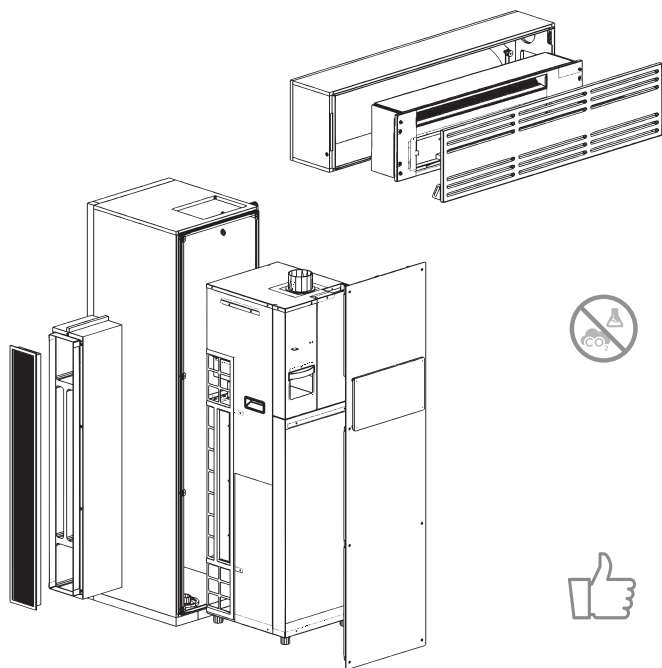

Sensors for automatic humidity, CO₂ and VOC management.



Remote control panel for controlling the unit and setting functions.



It is completely embedded into the masonry to seamlessly blend with the environment.

Unit technical data

	Specifications	UoM	Value
Internal Split	Air flow in summer air-conditioning mode	m ³ /h	230/290/400/460
	Sound power in summer air conditioning	dB(A)	38/38/47/49
	Air flow in winter air conditioning	m ³ /h	298/298/405/468
	Sound power in winter air conditioning	dB(A)	39/39/47/49
	Power consumption	W	35
	Dimensions (W x H x D)	mm	845 x 230 x 140
	Weight	kg	9
	Control type		wall-mounted
	Power supply		from the dissipation unit
	Sound pressure ⁽⁵⁾	dB(A)	26.5
Trivalent unit	Air flow in summer air-conditioning mode	m ³ /h	183/676/821
	Sound power in summer air conditioning	dB(A)	31/53/57
	Air flow in winter air conditioning	m ³ /h	165/658/803
	Sound power in winter air conditioning	dB(A)	40/52/57
	Refrigerant gas (charge)		R32 (0.55 kg)
	Power supply		220-240V - 1 Ph - 50 Hz
	Rated cooling current	A	2.4
	Rated heating current	A	2.2
	Max. current	A	5.5
	Maximum power consumption	kW	1.24
	Dimensions (W x H x D)	mm	330 x 1160 x 370
	Weight	kg	41
External air temperature limit in summer air conditioning mode	°C	+18 ~ +43	
External air temperature limit in winter air conditioning mode	°C	-10 ~ +24	

1. In compliance with EN 14825

2. Under average climatic conditions

3. Sound pressure level L_{1c} in accordance with UNI 8199, determined while keeping in a typical environment the temperature of 20 °C inside and 7 °C outside

4. In hyperventilation mode

5. Measured on a 30m² semi-anechoic environment at a distance of 3 m for split units at minimum speed

All Seasons dimensions

Setup for trivalent unit with window-side output

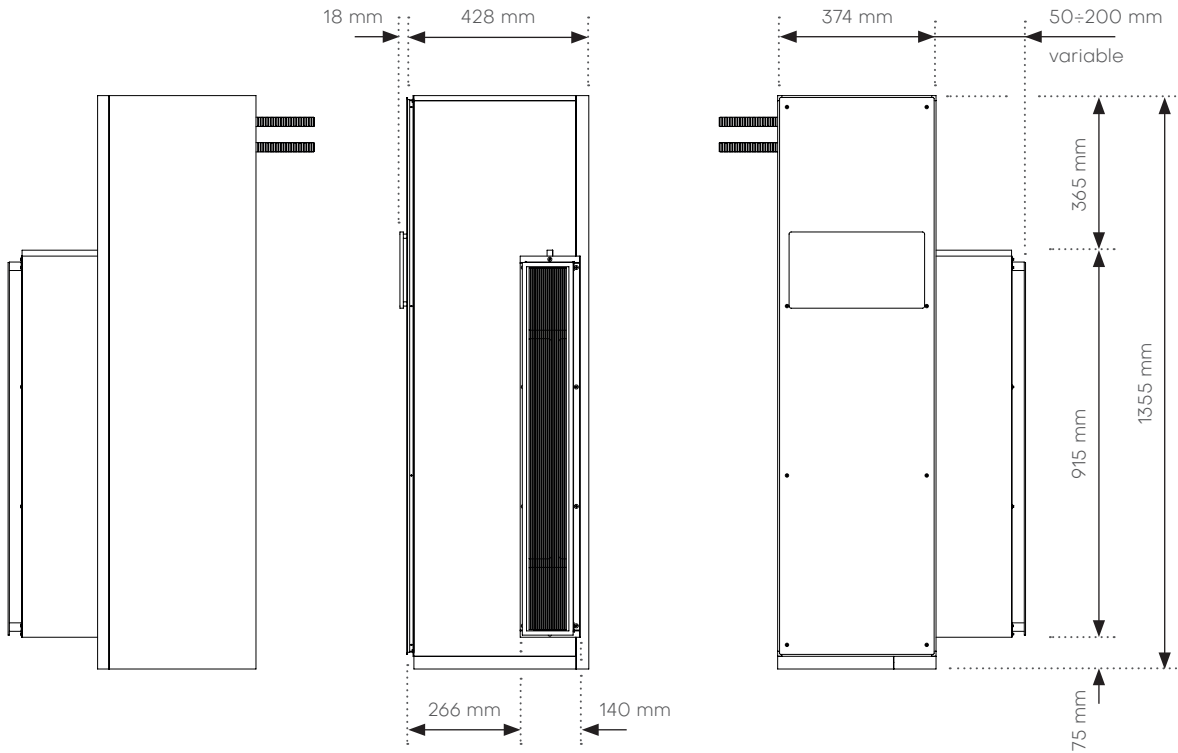

Setup for trivalent unit with facade output

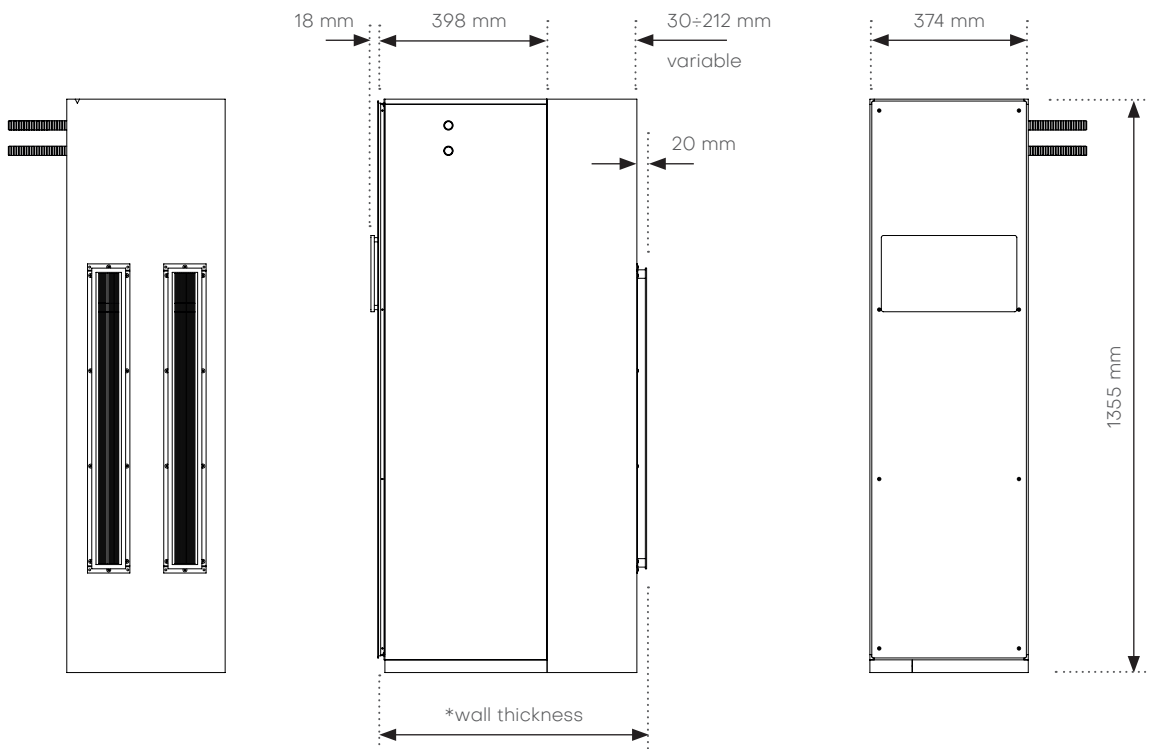

Setup kit for internal split unit

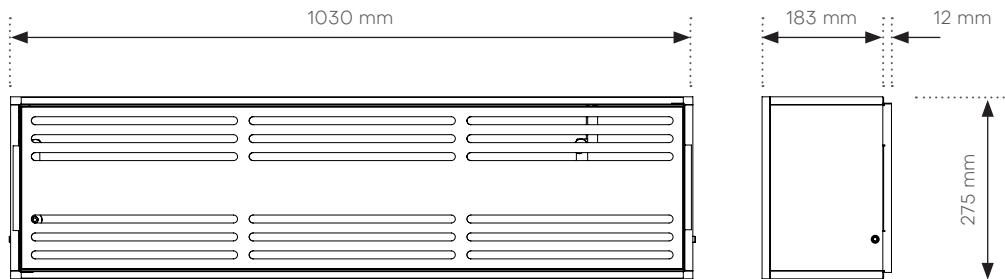

Measurements of masonry hole for trivalent unit with window-side output

Side	UoM	Masonry hole W x H
Inner wall	mm	415 x 1395
Shoulder (window-side kit)	mm	180 x 940

Wall thickness limits for trivalent unit with window-side output

Wall thickness	UoM	Plaster	Cladding
Minimum	mm	450	450

Measurements of masonry hole for trivalent unit with facade output

Side	UoM	Masonry hole W x H
Inner wall	mm	415 x 1395

Wall thickness limits* for trivalent unit with facade output

Wall thickness	UoM	Plaster	Cladding
Minimum	mm	450	450
Maximum	mm	630	630

Measurements of masonry hole for internal split unit

Side	UoM	Masonry hole W x H
Inner wall	mm	1070 x 315

Wall thickness limits for internal split unit

Wall thickness	UoM	Plaster	Cladding
Minimum	mm	195	195

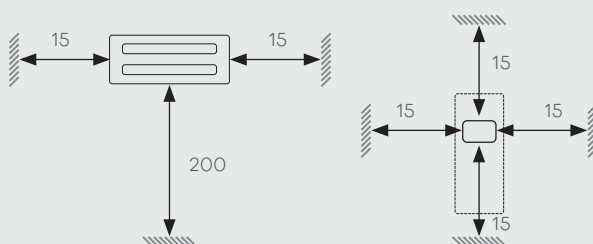

Internal split unit

Trivalent unit

Recommended minimum dimensions

	UoM	Split	Trivalent**
Above	cm	0	15
Below	cm	200	15
Left	cm	15	15
Right	cm	15	15

** Measurements from the filter inspection panel

Environment: let's not waste energy

The environment, sustainability and well-being are all subjects of major concern for Helty. This is why we promote not only the creation of **healthier and more comfortable dwellings and offices**, but also a culture of **energy saving**, resulting into the high performance of our products. Indeed, Helty Flow recovers up to 91% of the thermal energy that would normally be dispersed by opening windows for adequate room ventilation.

This heat is then used to warm up the incoming air, thus providing **significant savings on air conditioning costs, both for winter heating and summer cooling**.



Energy consumption

The enthalpy heat exchanger also recovers any latent heat contained in air humidity, thus achieving even greater savings. Furthermore, Helty Flow technologies consume less than 150 Wh per day, a quantity of electricity so low that keeping them running constantly costs **less than 6 cents a day***.

With a Controlled Mechanical Ventilation system with highly efficient heat recovery, such as Helty Flow, **optimal indoor air management** is achieved, without wasting energy and **reducing consumption and environmental pollution**.

*estimation based on average energy price in Italy.

HELTY[®]
Pure air for your home

HELTY®

Pure air for your home

Healthy breathing in every room



#healthybreathing



4MKTO00006635