

QUICK USER AND INSTALLATION MANUAL

Heat recovery unit Xflat

Quick manual will guide you thru quick installation of the unit, but in any case, can not replace full manual. Full manual is available at our web page, www.xvent.cz or you can download it by QR code.



Check, that in the spot where you will install the unit, there are not any electric wires, water, waste or gas pipes, which you can brake during installation. Check, that the parameters of electric power network, you would like to connect the unit to, comply with requests of the unit (production label).



Make sure that the installation of the unit will not interfere the static of the building and comply with all safety legislative requests. Before starting the installation, check the possibility of connection to the sewage system for draining the condensate from the unit.

1) Usage

- The Xflat unit is an air-conditioning device using ventilation technology with the recovery of heat (counter-current recovery exchanger) and humidity (enthalpy exchanger) with the option of automatic control of air output using AQS air quality sensors (accessories) or permanent ventilation - manual mode. The unit also has a burst ventilation mode - BOOST, which is started either on the control panel or with an external switch EXT2 with a return flap, using e.g.: in the toilet, in the bathroom. The regulation of the unit also enables remote ON/OFF control using the external contact EXT1 or, control using the superior BMS system (modbus RTU protocol) or even control using a web application (Wifi module). - The Xflat unit also enables the fan offset function for use, for example: in buildings with a fireplace. Air output, running time of BOOST mode and fans offset can be adjusted separately in the customer menu.

- The unit can be used in spaces with a maximum nominal flow rate of approx. 150 m³/h (depending on the type) at 150Pa ext. stat. pressure.

- The unit is intended only for horizontal or vertical installation on the wall and on the ceiling, so that it is possible to ensure the supply of fresh air and the extraction of waste air. The unit is equipped with three blind condensate outlets for each installation position.

- The unit is intended for indoor, covered and dry spaces with room temperature from +5 °C to +30 °C and with a maximum relative humidity of 70% non-condensing.



The supplied fresh air temperature from the outside environment can be in the range from -20 °C to +40 °C (applies to the version with preheating). If the temperature of the supplied air is lower than -20 °C, the unit may be automatically switched off to protect against possible damage.

2) Technical parameters

Type Xflat		XF1-015-ECSOHRXAS-0AO	XF1-015-ECSOERXAS-0AO
Typ rekuperačního výměníku		HRV	ERV
Nominal airflow* / BOOST**	m ³ /h	155 / 160	140 / 150
Acoustic level***	dB(A)	39,6	38,8
Weight****	kg	13	13,5
Power supply	V / Hz	1 ~ 230 / 50-60	
Nominal input* / BOOST**	W	106 / 115	101 / 110
Nominal current* / BOOST**	A	0,8 / 0,9	1 / 1,2
Thermal efficiency *****	Heat	%	75
	Moisture	%	66
Electric safety	IP	20	
Energy class (ERP)		Cold climate A+, mid climate A, warm climate A	Cold climate A+, mid climate A, warm climate B

* Nominal airflow (input, current) at external static pressure drop 150Pa

** BOOST mode - maximum intensive ventilation for set time period (ventilation intensity and time period is set in the user menu)

*** Acoustic pressure level in the free space in distance 3m (Q2) - 135m³/h - 110Pa

**** Weight of the unit without packaging

***** Recovery efficiency according to EN 308

Prohibited use of Xflat



- The unit must not be used to extract burning, glowing substances, flammable or explosive gases, aggressive media, liquids.
- The unit must not be installed close to the electricity socket, el. box, flammable materials, in environments with increased occurrence or risk of explosion, flammable substances, with increased dust and in environments with greater humidity.
- Neither the manufacturer nor the supplier is liable for damages caused by incorrect use of the units. The risk is borne by the user.

3) Installation of Xflat

- Minimum installation distances

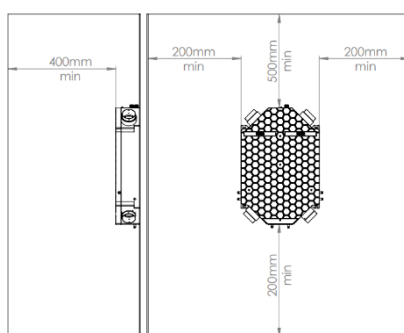

- Installation positions:

✓ ONLY FOR TYPE XF1-015-ECSOERXAS-0AO

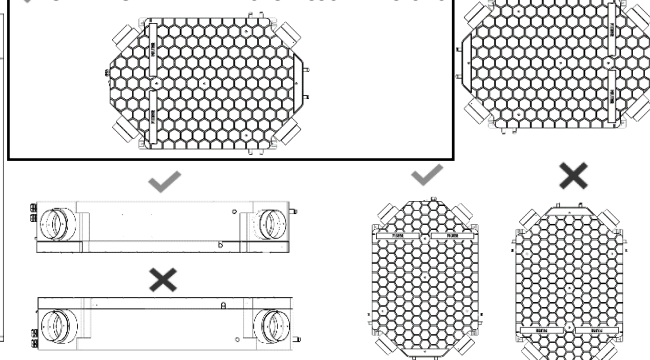

The Xflat unit must be installed and put into operation in accordance with the general and locally valid safety regulations, by a person with adequate education, experience and knowledge of the relevant regulations, standards and possible risks and possible dangers, or by a suitably trained service technician. **Failure to follow the installation procedure may result in damage to the unit, malfunction, and possible injury to the user's health and property.**

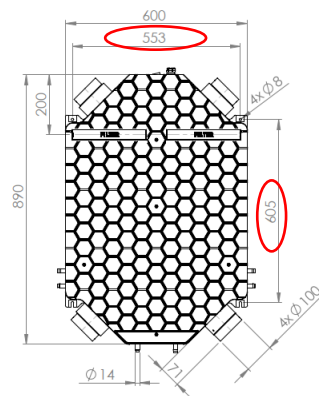
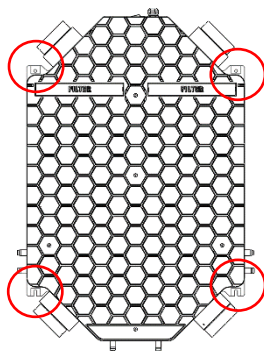
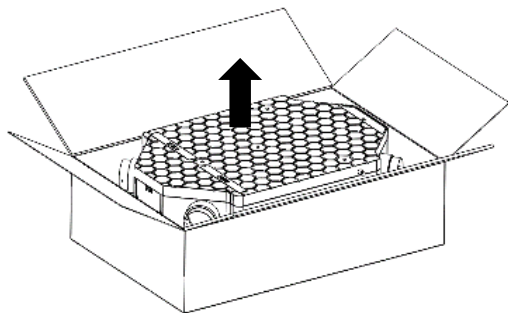

b) Choose the installation position taking into account the location of the condensate outlet. Align the anchor holes according to the dimensions on the unit, drill and mount the unit leveled using suitable screws. Do not tilt the unit.

Horizontal on the wall

Vertical on the wall

Under the ceiling

ATTENTION: THIS INSTALLATION POSITION ONLY FOR THE ENTHALPY CORE VARIANT (XF1-015-ECSOERXAS-0A0).

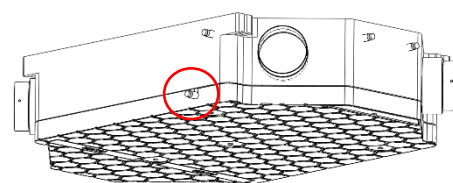
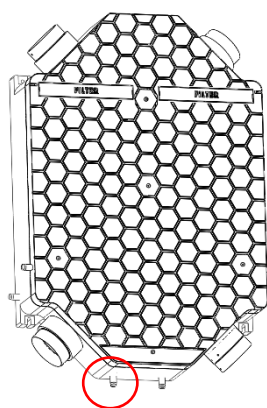
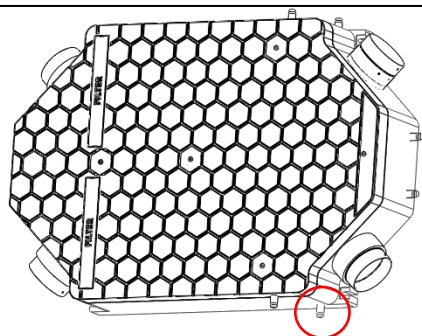

c) cut off the edge of the condensation outlet and remove any burrs

d) create a siphon by attaching the hose and tie straps

e) choose the correct siphon position for connection to the sewer

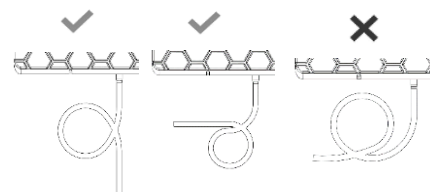
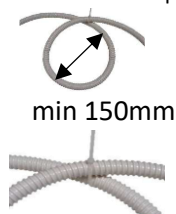
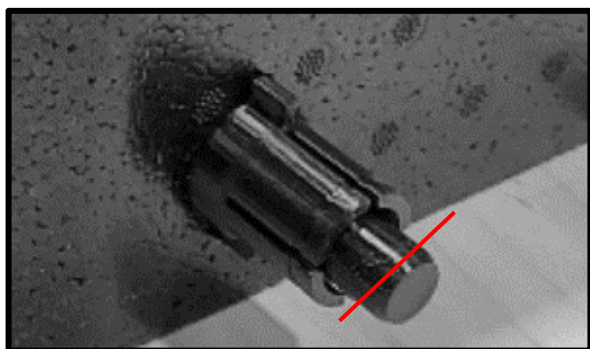

f) Fill the siphon by water, connect the hose to the outlet of the unit and secure with a strap

g) connect the siphon to the sewage system

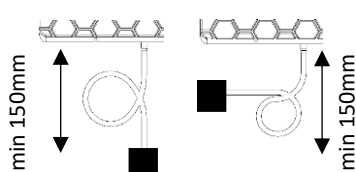
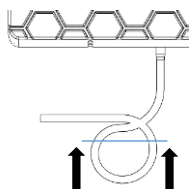

h) connect the air ducts to the Ø100mm nozzles according to the purpose

i) seal and insulate the joint - use the thermal insulation of the throats

INSULATION NECESSARY

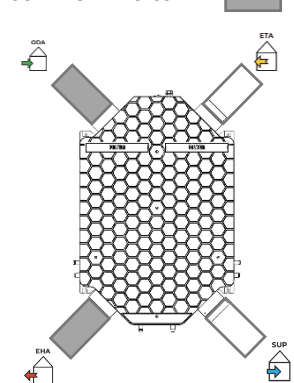
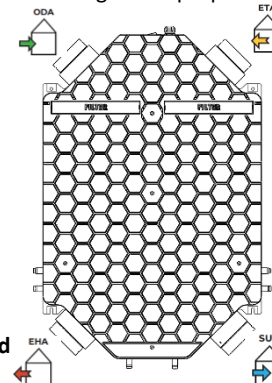

ATTENTION: in the case of using air conditioning in a ventilated building for cooling in the summer, it is necessary to connect the second condensate outlet - see full manual



- Before starting the unit for the first time or after a longer standstill, check the water trap. If you make a bend on the hose, pay attention to the correct bend radius to avoid "breaking the hose". To extend the siphon hose, always choose a hose - pipe of the same or larger diameter. Always choose the hose-pipe coupling with the smallest reduction of the inner diameter.

- All pipe connections that are connected to the unit must be sufficiently sealed so that there were no unwanted leaks and subsequent problems, e.g.: condensation. the connected piping must be of the same diameter as the unit's connection sockets. If a pipe with a smaller diameter is used, it may affect the air performance of the unit and thus reduce the lifespan of the fans.

4) Installation of controls for Xflat

- The controller is connected to the regulation of the unit by connection and communication cable with a length of 3 m.
- The controller is designed to be installed on the wall in the following way:

A) Surface-mounted installation - cables into the rail

- For installation, use electrical cable rails and an electrical installation surface-mounted box of the appropriate size with the possibility of connecting cables from the side.
- Open the controller – picture a)
- Disconnect all cables from controller - spring clamps with manual wire lock are used. Proceed with care to avoid damage.
- Install the controller box on the wiring box according to the mounting holes.
- Drill the central hole in the back of the controller to pass the cables
- Pull the cable through and connect according to the attached diagram in the controller box.

a) Open the controller

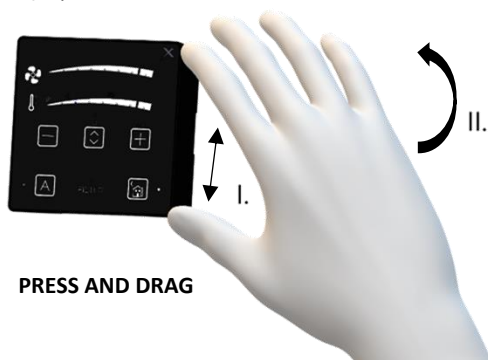

B) Concealed installation - cables in the wall

- The connection cables between the unit and the controller must be part of the construction preparation - under the plaster. One end ends at the installation location of the unit, the other at the location of the controller in the flush-mounted box.
- Cables required for installation:
 - 8-cores UTP cable without terminals - connection of power supply and motor control
 - 8-cores UTP cable with RJ45 8/8 terminals - communication connection between the unit and the controller.
- Max length of connecting cables is 10m.
- Loosen the grommet nuts and unscrew the regulation cover plate from the unit (see chapter 5.) and disconnect the connection and communication cable according to the diagram.

b) Controller dimensions

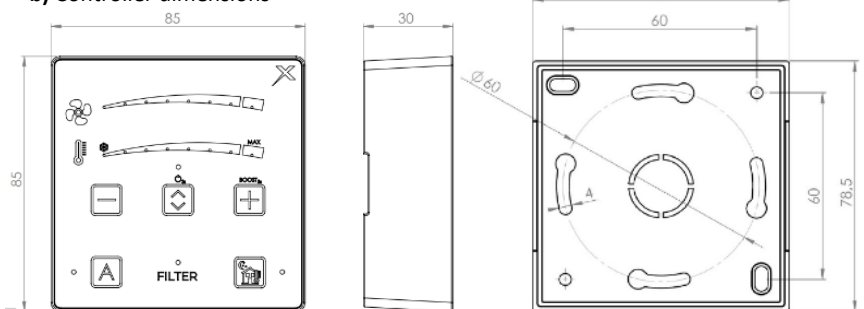

c) Connection diagram

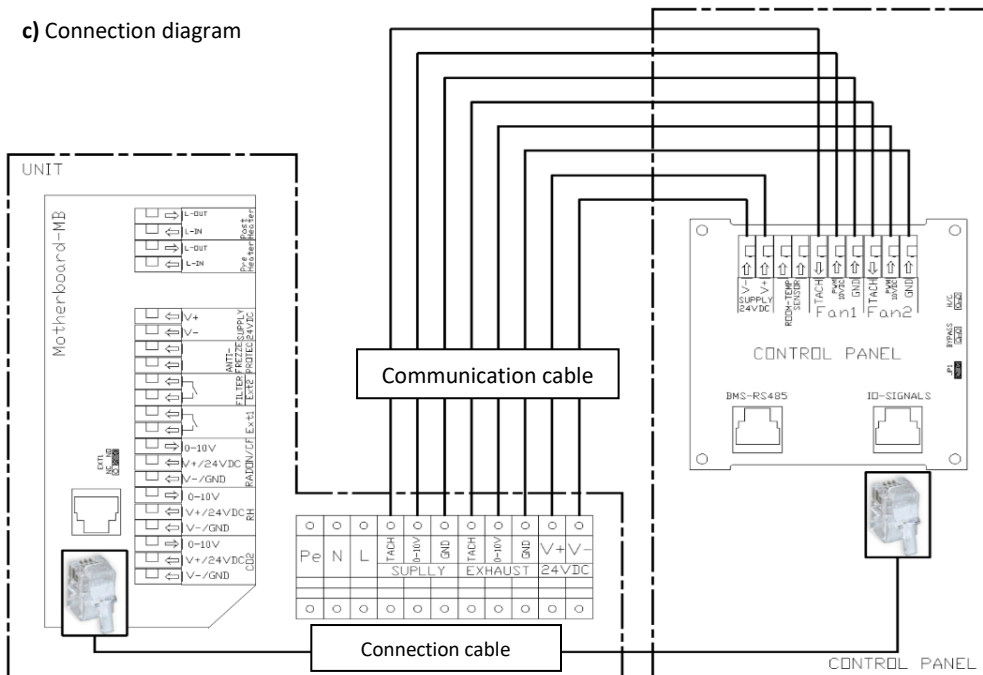

- d) communication cable terminals**
- Equip the communication cable with terminals - RJ45 8/8 connectors
 - The RJ connectors on the UTP cable must be connected as a direct connection (both connectors are connected the same)

Direct connection

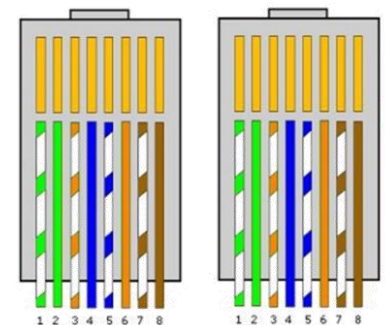

! Pay attention to the correct connection - observing the positions of the cables and correctly inserting the cables into the.

4) Electro installation – connection to the electric power network

- Before starting any installation work, make sure that the wiring box or mains power socket you want to use to connect the unit is equipped with a protective (green-yellow) wire or contact (pin).
- If you use main plug to connect the unit, it must remain accessible at all times so that the unit can be safely disconnected from the mains in the event of an emergency.
- The relevant current circuit must be protected by a maximum of 16 A in the electrical power distribution.
- The electrical connection of the unit to the network may only be carried out by persons qualified for this activity with a valid authorization and knowledge of the relevant standards and directives.
- This unit belongs to the group of products with Y-type connection. If the power supply is damaged, it must be replaced by the manufacturer, its service center or a similarly qualified person in order to avoid a hazardous situation.
- The supply voltage to the unit 1~230V/50-60Hz must not be adjusted in any way, otherwise there is a risk of unit damage.

- Xhouse unit connection to the power

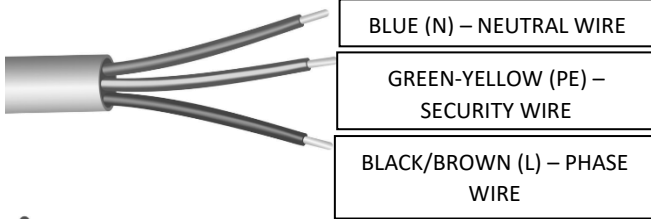

- Connection of the unit in to the electric box

- Input wire is ready from the manufacturer for connection in to the electric box.
- For connection of the income wire to the electric power network use appropriate components. (IE connectors, spring clamps)
- **Connection of the unit to the electric socket**
- Income wire is possible to connect with plug with security connector (pin) – this is not part of the delivery.



Installation of the income wire to the electric box or installation of the plug to the income wire and connection to the electric power network has to be performed only by authorised person and inline with safety law instructions valid in the area of the installation.

5) Controls – electro accessories to the Xflat

- For the correct operation of the unit (in manual mode), there is no need to connect anything else. It is ready for immediate use after installation on the wall. For operation in automatic mode, you must connect the air quality sensor accessories CO2 (NL-ECO-CO2) or RH (NL-ECO-RH).

- Connection of electrical accessories



Before connecting electrical accessories, always switch off the unit at the remote control and the main switch.

- Connect the electrical accessories in the control box. To connect accessories, use the membrane multi-through. To access the control box, proceed as follows:

a) loosen the grommet nuts

b) unscrew the securing screws of the regulation cover - remove the cover

c) pass the cable through the membrane

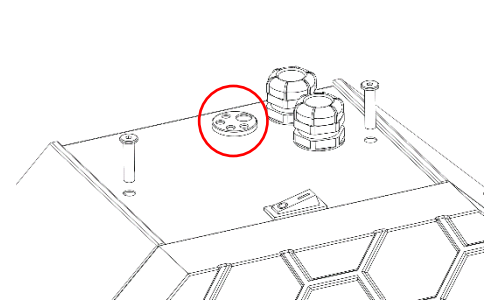
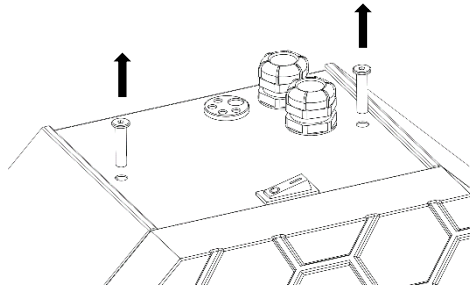
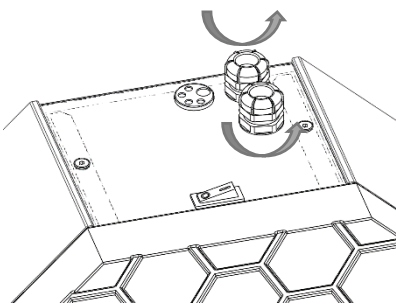

e) Connect the cable to the appropriate terminals in the motherboard according to the

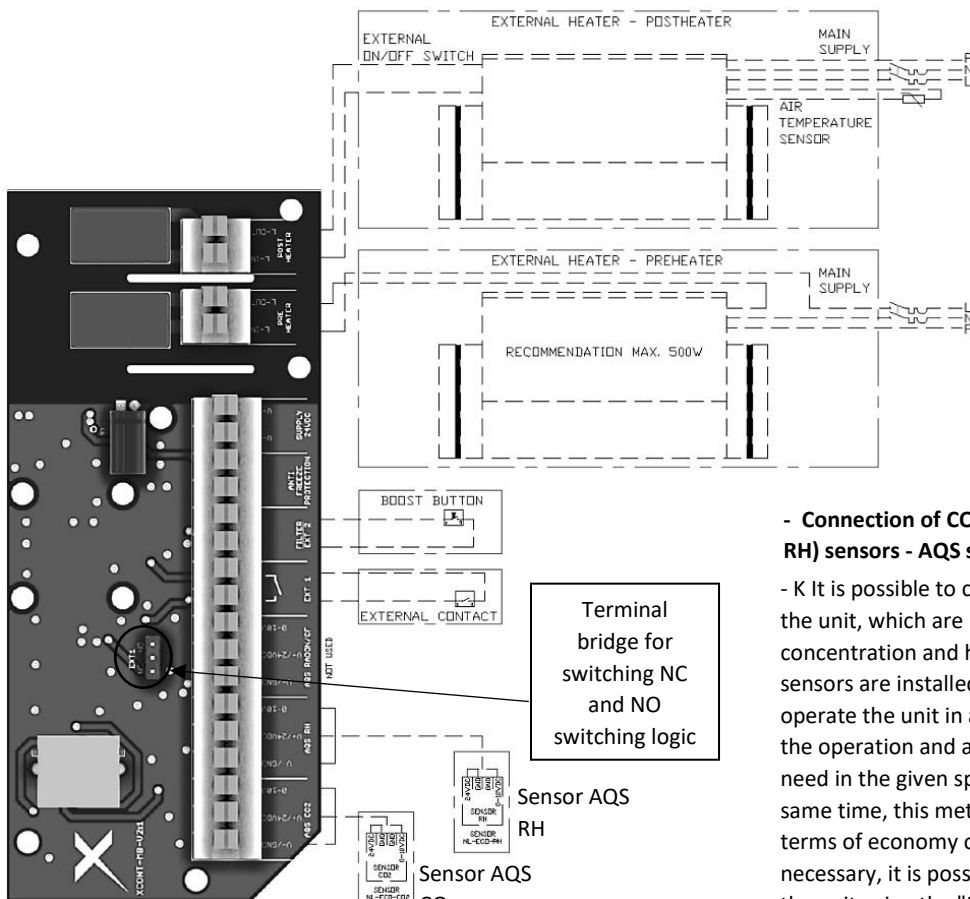

- Spring clamps with manual wire locking are used to connect the individual components. Both a licna-type conductor (cable with a sleeve) and a solid conductor (wire) can be installed in the terminals with a cross-section ranging from 0.5 to 1.5 mm², exposed length 10 mm. Before inserting the wire into the terminals, first press the locking orange button. Then insert the wire, release the lock and check that the wire is properly secured by pulling slightly on the clamp. If you need to remove the wire from the terminal, the procedure is the same. Choose the optimal conductor cross-section according to the length of the conductor route.

- Connection of CO2 (NL-ECO-CO2) and RH (NL-ECO-RH) sensors - AQS sensors (AQS CO2)

- It is possible to connect 2x AQS sensors (1xCO2 and 1xRH) to the unit, which are used to measure the content of CO2 concentration and humidity – RH in the air at the place where the sensors are installed. Thanks to the sensors, it is possible to operate the unit in automatic mode, which automatically controls the operation and air output of the unit according to the current need in the given space where the sensors are installed. At the same time, this method of management is the most efficient in terms of economy of operation – it only ventilates as needed. If necessary, it is possible to connect up to 8 sensors of one type to the unit using the "PRO-SUM-08" accessory.

- Technical parameters of AQS sensors for connection to the unit

- o Power supply 24VDC
- o Analogue output 0- 10VDC
- o Max input 5W
- o Analogue input resistance 100kΩ



- Functionality of the unit for connecting AQS sensors

- The unit responds with continuous control to the need for ventilation triggered by the sensor in real time
- the switching concentration of the CO2 sensor is 800ppm, RH 65%
- cut-off concentration of the CO2 sensor is 700PPM, RH 60%



The supply GND is common with the Analog input GND. If the connection is not followed, there is a risk of destroying the control board.

- External contact connection - EXT 1

- The regulation of the unit allows the connection of an external contact for remote switching on and off of the unit (remote ON/OFF control). The external contact is designed as potential-free, it can be switched by e.g.: magnetic contact, remote switch, time relay.

- Technical parameters of the external contact EXT 1

- o Switching voltage 24 VDC / 5mA
- o The contact can change the switching logic by switching the terminal bridge to NC or NO switching logic (factory setting).

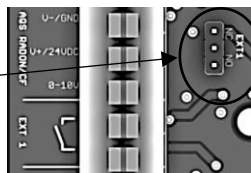

- Functionality of the unit when controlled by an external contact EXT 2

- The external contact switches the unit on and off (same functionality as the ON/OFF button on the controller) with logical termination or activation of all running processes at the time of switching off, switching on.

- If the unit is turned on/off by an external contact, it can be turned off/on by the controller on the unit.

- External contact connection – EXT 2 – BOOST

- The regulation of the unit allows the connection of an external button (flap switch with automatic return of the flap - e.g.: bell button with return spring) to start the shock ventilation mode for a set time - BOOST (hereinafter referred to as BOOST) for use e.g.: in the bathroom

- Technical parameters of the external contact EXT 2 - BOOST

- o Switched voltage 24 VDC / 5mA
- o The external contact is designed as potential-free
- o The factory setting is max. air output, run time 1 min.
- To prematurely end the BOOST mode, hold the button for approx. 2 seconds. BOOST mode can also be turn on from the controller.



- Functionality of BOOST mode – EXT 2

- An external switch turns on the BOOST mode at the set air output and run time. After the running time of the BOOST mode is over, the unit returns to the previous mode.

- Connecting the unit to the superior BMS system and to control using the WifiModule web application

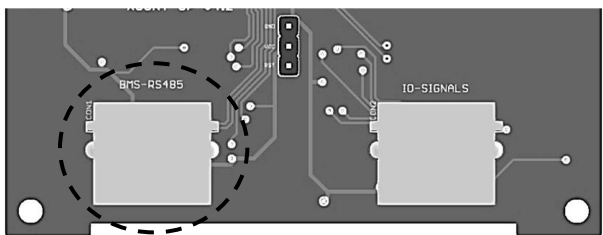

- The unit can be connected to the superior BMS system using the modbus RTU communication protocol and with the "WifiModule" accessory also for control using a web application.

- Connect the communication cable for control by the superior BMS system or the WifiModule accessory to the controller in the connector labeled BMS-RS485. Equip the UTP communication cable with RS485 8/8 connectors. Connector connection type – DIRECT.

- The description of the communication protocol is given in the separate document "D-502-xxx-Vxxx-xxx-MN-CENTRAL-MODBUS".

- Connecting an external electric preheater - PREHEATER

- It is possible to connect an external electric heater - preheating (see accessory "XF-PH-100-03-1f") with a maximum power of 1500W, voltage 1x230V to the unit.
- Recommended heater power min 300W to 500W.
- The unit switches only the supply phase - potential (L-IN) to the heater (L-OUT).
- The preheating switching logic is subject to the temperature on the antifreeze sensor, which is located in the recovery exchanger in the exhaust air branch.
 - o Switching temperature – 3°C (temperature on the antifreeze sensor).
 - o Opening temperature - 5°C – termination of anti-freeze protection –
- If the preheating is not enough, additional logics are triggered for preheating.

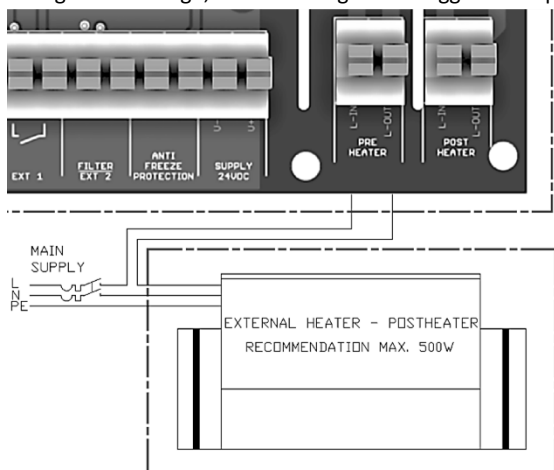

- Connecting an external electric postheater - POSTHEATER

- It is possible to connect an external electric heater with a maximum power of 1500W, voltage 1x230V to the unit.
- The unit switches only the supply phase – potential (L-IN) to the heater (L-OUT) in logic:
 - o If the unit ventilates, the phase is switched - the potential is closed
 - o If the unit is standing, the phase is switched - the potential is open - the post-heating cooling function is active - 3 min
- the unit's regulation cannot detect the presence/absence of reheating, therefore the reheating cooling function is always active.

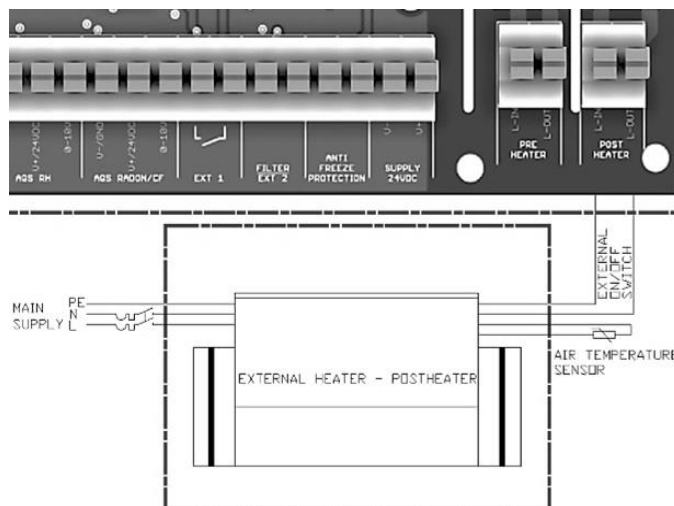



- Install the heater according to the heater manufacturer's instructions. The manufacturer of the unit is not responsible for incorrect installation of pre-heating or post-heating or for damage to property or health.
- The supply wiring for powering the reheater must be handled by a separate supply including the switched phase controlled by the unit, in no case may the reheater be powered from the unit.

- Block diagram of the connection of the Xflat unit

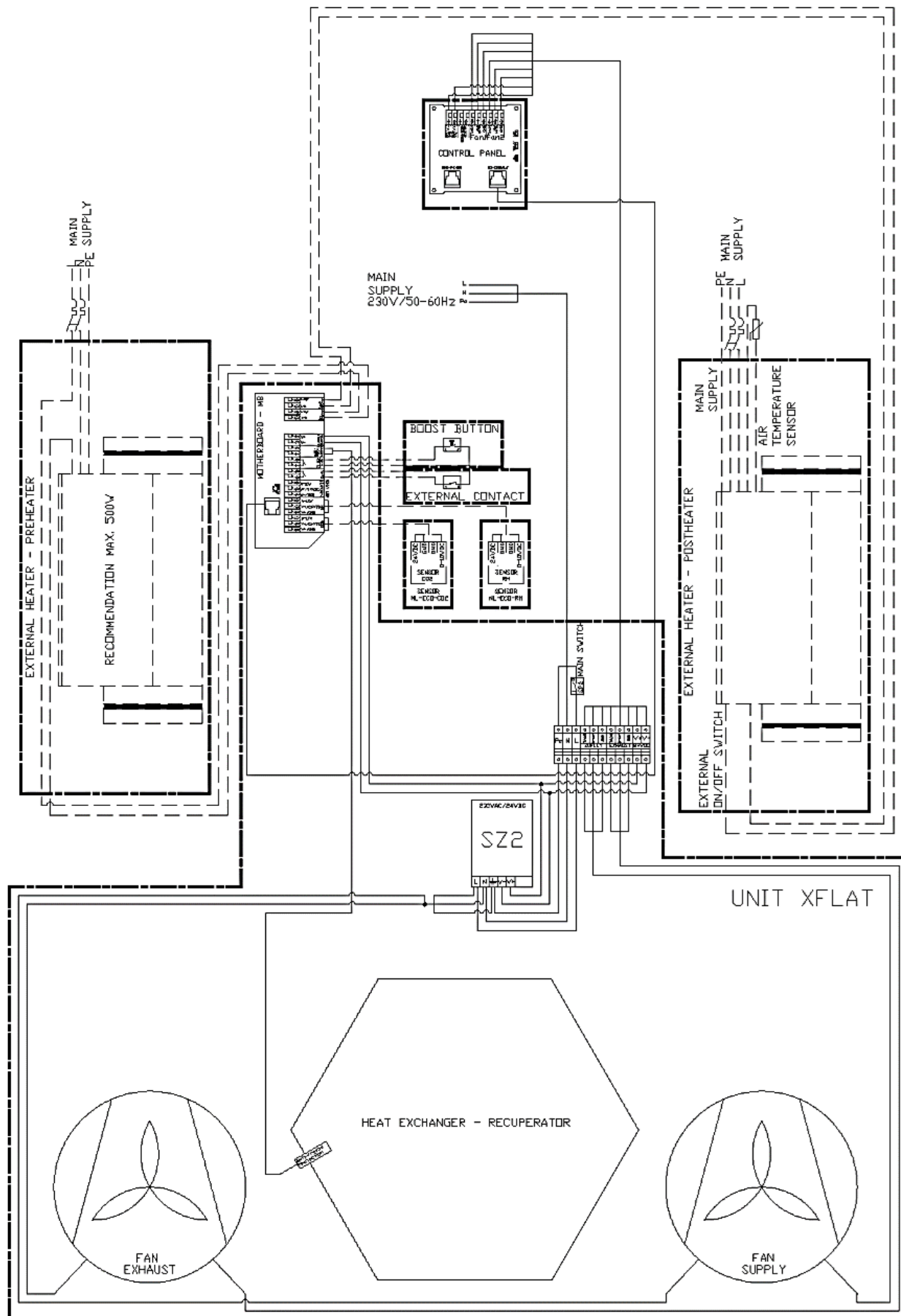

- further information on unit operation, service is given in the full manual or in Quick-first start-up (placed on the cover of the unit).