

OPERATING AND INSTALLATION INSTRUCTIONS
CENTRAL HEAT RECOVERY UNITS
XFLAT II.
XF2-035 / XF2-045
Regulation WIFI

CONTENTS

1. General information	5
1.1. Introduction	5
1.2. Warnings and symbols	5
1.3. Using the Xflat Unit - XF2	6
1.3.1. Definition of the unit	6
1.3.2. Forbidden environments, use, installation of the XF2 unit:	7
1.4. Transport, delivery and storage control	7
1.4.1. Transportation.....	7
1.4.2. Delivery control	8
1.4.3. Storage	8
1.5. XF2 Package Contents	8
1.6. Before you start the installation.....	8
2. Technical parameters	9
2.1. Key parts of the unit	9
2.1.1. Unit casing (position 1.)	10
2.1.2. Unit Lid (Position 2)	10
2.1.3. Connection Sockets (Position 3)	10
2.1.4. Power cord (position 4).....	10
2.1.5. Production Plate (Position 5)	10
2.1.6. RJ connector (position 6)	10
2.1.7. Self-tapping screw Ø4.2x35 (position 7.)	10
2.1.8. M6x25 Screw (Position 8).....	10
2.1.9. Filter caps (position 9).....	10
2.1.10. Filters (position 10)	10
2.1.11. Fans (Position 11)	10
2.1.12. Heat exchanger (position 12.)	10
2.1.13. Box regulation (position 13.).....	10
2.1.14. Condensate outlet (position 14.).....	10
2.1.15. Power switch (position 15.).....	10
2.1.16. Screw grommet (position 16.).....	10
2.1.17. Right/Left Version Switch (Position 17)	11
2.1.18. Nominal airflow Switch (Position 18)	11
2.1.19. Rubber grommet (position 19)	11
2.1.20. Wifi label (position 20.).....	11
2.1.21. LED status (position 21)	11
2.1.22. WIFI LED (position 22).....	11
2.1.23. Bypass flap (position 23rd).....	11
2.2. Main dimensions of the XF2-035 unit; XF2-045:	11
2.3. Technical parameters of Xflat units – XF2.....	12
2.3.1. Basic technical parameters	12

2.3.2.	Airflow curves.....	13
2.3.3.	Acoustic data XF2-035.....	15
2.3.4.	Acoustic data XF2-045.....	16
2.3.5.	Heat and Moisture Recovery Efficiency – XF2-035.....	18
3.	Installing the Unit	24
3.1.	General information, recommendations and safety when installing the Xflat unit – XF2.....	24
3.1.1.	Electrical Safety Before Unit Installation	24
3.1.2.	Unpacking the Xflat Unit - XF2	24
3.1.3.	Unit Location	25
3.1.3.1.	Location and operation of the unit in the area with a fireplaces.....	25
3.1.3.2.	Location and operation of the unit in the air conditioning unit area.....	25
3.1.4.	Minimum installation distances	25
3.1.5.1.	Spigot Orientation - Right Unit Version - Factory Setting.....	26
3.1.5.2.	Spigot orientation - left version of the unit	26
3.1.6.	Prohibited Xflat 350/450 Installation Positions	26
3.2.	Installing the Xflat Unit - XF2.....	27
3.2.1.	Mounting Hardware Required to Install Xflat XF2 - General Requirements	27
3.2.2.	Installing the unit on a wall or ceiling	27
3.2.3.	Condensate drain connection – siphon	28
3.2.3.1.	Condensate drains right version of the unit	28
3.2.3.2.	Condensate drain left version of the unit	29
3.2.3.3.	Connection of the condensate drain to the siphon	29
3.2.4.	Connecting the air duct to the unit	31
3.2.4.2.	Removing the Plug from the outlet	31
3.3.	Wiring – connection to the mains.....	32
3.3.1.	General information - safety.....	32
3.3.2.	Connecting to the mains	33
3.3.2.1.	Connecting the unit to the wiring box.....	33
3.3.2.2.	Connecting the unit to an electrical outlet	33
3.3.2.3.	Unit fuse recommendation XF2-035; XF2-045	33
3.3.3.	Display of electrical parameters.....	33
4.	Controls	34
4.1.	General information - safety	34
4.2.	Setting the unit with mechanical switches	34
4.2.1.	Right/Left Unit Switching	34
4.2.2.	Settings – switching the rated power of the unit.....	34
4.3.	Connecting accessories to the control	35
4.3.1.	Access to control board	35
4.3.2.	Connection of electrical accessories, signaling	37
4.3.2.3.	Connecting the unit to the master BMS	39
4.3.2.4.	Connecting AQS sensors	40

4.3.2.5.	Connecting an external contact EXT1 – ON/OFF	41
4.3.2.6.	Connecting an external EXT2 – Boost contact.....	42
4.3.2.7.	External Electric preheater – (PREHEATER) – Order Code – see pricelist	43
4.3.3.	Connecting an external electric postheater – (POSTHEATER) – Order Code – see pricelist	44
5.2.	Getting the unit up and running	46
5.2.1.	Turning on the unit	46
5.2.2.	Create an account in the WIFImodule.eu web app	47
5.2.3.	Confirmation of the registration email	48
5.2.4.	Log in to the app	49
5.2.5.	Initial application setup	50
5.2.5.1.	Setting up of the building.....	50
5.2.5.2.	Add a unit	51
5.2.6.	Pairing the unit with the app – APP.....	53
5.2.7.	Verification of unit functionality and control	56
5.3.	Basic description of controlling the unit via APP.....	56
5.3.1.	Setting the air output of the unit	57
5.3.2.	Description of the operating states of the unit – signals of the STATUS LED	57
5.3.3.	Hidden control functions	58
5.3.3.1.	Temperature conditions for starting automatic bypass	58
6.	Replacing filters	59
6.1.	Filter removal	59
6.2.	Filter Entry.....	59
6.3.	Filter Countdown Reset.....	59
7.	Regular maintenance and cleaning of Xflat units	60
7.1.	Inspection – cleaning the exterior of the unit	60
7.1.1.	Visual inspection of the unit shell	60
7.1.2.	Visual inspection of the supply cable	60
7.2.	Inspection – cleaning the interior of the unit.....	61
7.2.1.	Cleaning the fan chamber and fans	62
7.2.2.	Visual inspection and cleaning of the heat recovery exchanger.....	63
7.2.3.	Visual inspection and cleaning of the integrated preheater – XF2-xxx-xxxxxxPxW-1A0	64
7.2.4.	Reassembly – unit sealing XF2-035; XF2-045	64
7.2.5.	Visual inspection – cleaning of external preheater, postheater – if installed	65
8.	Service	66
8.1.	Error messages – troubleshooting procedure	66
8.2.	Failure persists.....	67
9.	Decommissioning, dismantling and recycling	67
10.	Warranty	67
11.	Conclusion	68

1. General information

1.1. Introduction

- This document "Operating and Installation Instructions" is intended for the second generation Xflat central heat recovery units with a nominal flow rate of 350m³/h (**XF2-035-ECxxxxxxW-1A0**) and 450m³/h (**XF2-045-ECxxxxxxW-1A0**) (hereinafter referred to as the unit). At the same time, it is superior to a brief manual located directly on the unit, the so-called "Quick Manual".
- **Assembly and wiring of the unit may only be carried out by a trained person with the appropriate authorization for wiring electrical equipment, who has the appropriate tools and means at his disposal. When assembling, all instructions and recommendations given in this manual must be followed**
- A detailed understanding of this document is important for the correct and safe installation and operation of the unit. Failure to comply with the conditions specified in this document may result in the unit malfunctioning.
- Keep the unit manual for future reference after reading it beforehand.
- It is forbidden to interfere in any way with the internal wiring of the unit other than that specified in this manual. Due to the continuous development of our products, we reserve the right to change this manual without prior notice.
- Children and persons with reduced physical, sensory or mental capabilities, or lack of experience and knowledge, may only use the unit under supervision or if they have been instructed to use the unit in a safe way and understand the hazards involved.
- Children are not allowed to play with the appliance.



1.2. Warnings and symbols

- In the operating instructions, on the packaging and on the product, the following names and symbols are used for particularly important information :



Warning, pay attention to all hazard warnings and warnings as well as instructions for precautions.



Danger, observe all warnings, risk of electric shock or a situation that could result in death or serious injury if not avoided.



Link to another part of the manual.



Caution – read the operating instructions – separate product (e.g. accessories) before use



Connecting the protective wire.



Warning of the correct position when handling and storing the packaging.



Warning of the need for protection against moisture. The product – packaging marked with this mark must not be transported on open means of transport and stored in unroofed buildings and on the ground without a pad.



Warning about the fragility of the contents of the product and the need to handle the packaged product carefully.

FRAGILE
KEEP DRY

Warning of the need to protect against moisture and the fragility of the product inside the packaging.

1.3. Using the Xflat Unit - XF2

1.3.1. Definition of the unit

- The unit is offered in 2 flow variants:
 - a) **XF2-035-ECxxxxxxW-1A0** (hereinafter referred to as unit XF2-035) – Nominal flow rate of the unit 350 m³/h with the possibility of mechanical switching on the body of the unit to a nominal flow rate of 300 m³/h
 - b) **XF2-045-ECxxxxxxW-1A0** (hereinafter referred to as unit XF2-045) – Nominal flow rate of the unit 450 m³/h with the possibility of mechanical switching on the body of the unit to 400 m³/h
- The XF2 unit is an air handling device using heat recovery ventilation technology (heat recovery heat exchanger – XF2-035-xxxxHRxxW-1A0, XF2-045-xxxxHRxxx-1A0) and humidity (enthalpy heat exchanger – XF2-035-xxxxERxxx-1A0, XF2-045-xxxxERxxW-1A0) with the option of an integrated pre-heater built into the unit or with the possibility of connecting an external postheater (not included in the unit), which is powered and controlled directly from the unit control.



The unit is equipped with a mechanical bypass with an automatic open/close function based on the inlet temperatures to the unit. Description of the function is given in separate chapter 5.3.3.1.

- The unit can be operated in **two ventilation modes**:
 - o **Manual** – forced ventilation. The unit ventilates permanently according to the power set by the user
 - o **Automatic** – ventilation according to air quality sensors (AQS). Up to two independent AQS sensors - CO₂, RH and Radon (accessories „NL-ECO-CO₂-P111“ and „NL-ECO-RH-P111“) can be connected to the unit as standard, which allow the unit to ventilate only when needed. If it is required to connect a larger number of sensors, up to 8 sensors from each measured parameter can be connected using the "PRO-SUM-08" accessory. The user only sets the power of the unit (airflow) according to the required air exchange (number of people) in the ventilated areas and the unit ventilates according to the actual need – proportionally adjusting the power according to ventilation requirement.

The unit can be controlled:



- - o **Using the web application – WIFImodule.eu** – default control. Functionality described in a separate chapter 5.2.2.
 - o **Wall-mounted wired controller** – not included in standard delivery must be ordered as an accessory - XCONT-TR-CENT-COMFORT. Connection of accessories in separate chapter 4.3.2.1.
 - o **Wireless RF remote controller** – not included in the standard scope of delivery must be ordered as an accessory - RF-REMOTE-CONTROLLER. Connection of accessories in separate chapter 4.3.2.2.
 - o Using the higher-level BMS system via the Modbus RTU communication protocol. Addressed in a separate chapter 4.3.2.3.
- The unit can be used to connect the air supply from the right (right version) and from the left (left version) according to the ordered configuration of the unit:



- o Unit configuration without integrated preheater (XF2-xxx-xxxxxxXxW-1A0)
 - Switching right/left versions can be done:
 - rocker / mechanical switch on the control cover (R/L) - the factory setting of the unit is the right design. Addressed in a separate chapter 4.2.1.
 - using the commissioning app – designed for authorized and trained technicians
- o Configuration of the unit with integrated preheater (XF2-xxx-xxxxxxPxW-1A0) specific version must be ordered
 - Right Version – XF2-xxx-xxxxxxPRW-1A0
 - Left version – XF2-xxx-xxxxxxPLW-1A0



The connection of the duct to the unit from the front and side is covered in a separate chapter 3.2.4.1.



The unit also has the option of switching the nominal flow in the following ways:

- o A rocker / mechanical switch is located on the body of the unit on the control cover. Factory setting unit is output 2. Addressed in a separate chapter 4.2.2.

- XF2-035
 - Output 1 - 300 m3/h at a disposition pressure of 200 Pa
 - Output 2 - 350 m3/h at a disposition pressure of 200 Pa
- XF2-045
 - Output 1 - 400 m3/h at a disposition pressure of 200 Pa
 - Output 2 - 450 m3/h at a disposition pressure of 200 Pa
- using the service app – intended only for authorized service technicians
 - Possibility of setting the flow rate per 1m3/h in the range of 30% to 100% of the nominal airflow
 - XF2-035 – allows you to set the airflow rate from 105 to 350 m3/h
 - XF2-045 – allows you to set a airflow rate from 135 to 450 m3/h
- The unit is designed only for wall-vertical (only for versions without preheater - XF2-xxx-xxxxxxXUW-1A0) and under-ceiling horizontal installation.
- The unit has constant flow technology – the flow does not decrease with increasing external pressure in the ducts (different pressure loss of individual ventilation systems). The unit still maintains the user's desired airflow rate up to the maximum external pressure.
- The unit is designed for continuous operation with the possibility of using a manual mode of operation (continuous ventilation) or with the possibility of automatic operation (demand control ventilation – as required using air quality sensors – AQS).
- The unit is designed for indoor and dry spaces with a room temperature of +5 °C to +30 °C and a maximum relative humidity of 70% non-condensing.
- The maximum working altitude of the unit is 2000 m above sea level.
- **The supplied fresh air temperature from the outside can range from -20 °C to +40 °C (applies to the version with connected preheater). If the supply air temperature is lower than -20 °C, the unit may automatically shut down to protect against possible damage.**



1.3.2. Forbidden environments, use, installation of the XF2 unit:



- **for extracting burning or glowing substances!**
- **for the extraction of easily flammable or explosive gases,**
- **to extract aggressive media,**
- **for suction of liquids of all kinds,**
- **in environments with an increased occurrence or risk of explosion, flammable substances and increased dustiness, or airborne containing other harmful impurities,**
- **in environments with a higher incidence of condensing moisture, such as: bathrooms, swimming pools, saunas, etc.,**
- **the unit must not be installed just below an electrical outlet or wiring box,**

Damages caused by improper use of units (e.g. drying of new buildings) are not liable by the manufacturer or supplier. The risk is borne by the user himself.

1.4. Transport, delivery and storage control

1.4.1. Transportation



- It is important to transport the product in the position indicated by the symbol on the packaging.
- The packaging must not be overloaded with additional weight than the manufacturer allows.
- The packaging must not be exposed to environmental influences.
- The transport air temperature must be between -25 and 55 °C.
- The transport relative humidity must be between 10 and 90 % non-condensing.
- **Use adequate tools for transport to prevent damage to the goods and damage to the health and safety of people.**
- In the event of further transport without the original packaging or with the original packaging changed, it must be ensured that the device is optimally secured and protected against damage.

1.4.2. Delivery control

- Before starting the installation and before unpacking the unit from the box, it is necessary to check that there are no traces of damage on the packaging. In case of damage to the packaging, write a damage report and please contact your carrier.
- Check if the product you ordered is correct. After unpacking, check that the unit and other components are in good condition. Please report any non-compliance immediately to the supplier.
If an order complaint is not made immediately after delivery, it will not be taken into account later.

1.4.3. Storage

- If the unit is not to be installed immediately after purchase, it must be stored in an indoor, non-condensing environment at temperatures ranging from +5 to +40 °C. If the product is transported at temperatures lower than 0 °C, it must be stored in the working environment where it will be installed for at least 2 hours before installation.

1.5. XF2 Package Contents

- | | |
|--|----|
| - XF2 Unit | 1x |
| - Condensate drain hose Ø33/25 – length 1m | 1x |
| - Tie Strap 2.5x120 | 2x |
| - Quick manual + safety of use | 1x |
| - Energy label for nominal flow rate 350 m ³ /h | 1x |
| - Energy label for nominal flow rate 450 m ³ /h | 1x |

1.6. Before you start the installation



- **Check that there are no electrical or other wiring (e.g.: gas, water, etc.) running in the interior at the installation site of the unit (on the ceiling, wall) that could be disturbed during installation.**



- **Make sure that the installation of the unit, including openings in the wall, wall (according to the selected installation position) for the passage of the connecting duct, does not endanger the statics of the building and meets all legislative safety requirements.**

- Check the method of installing the condensate drainage of the unit into the sewer system or in another way that will ensure trouble-free condensate drainage

2. Technical parameters
2.1. Key parts of the unit

Pic. 1

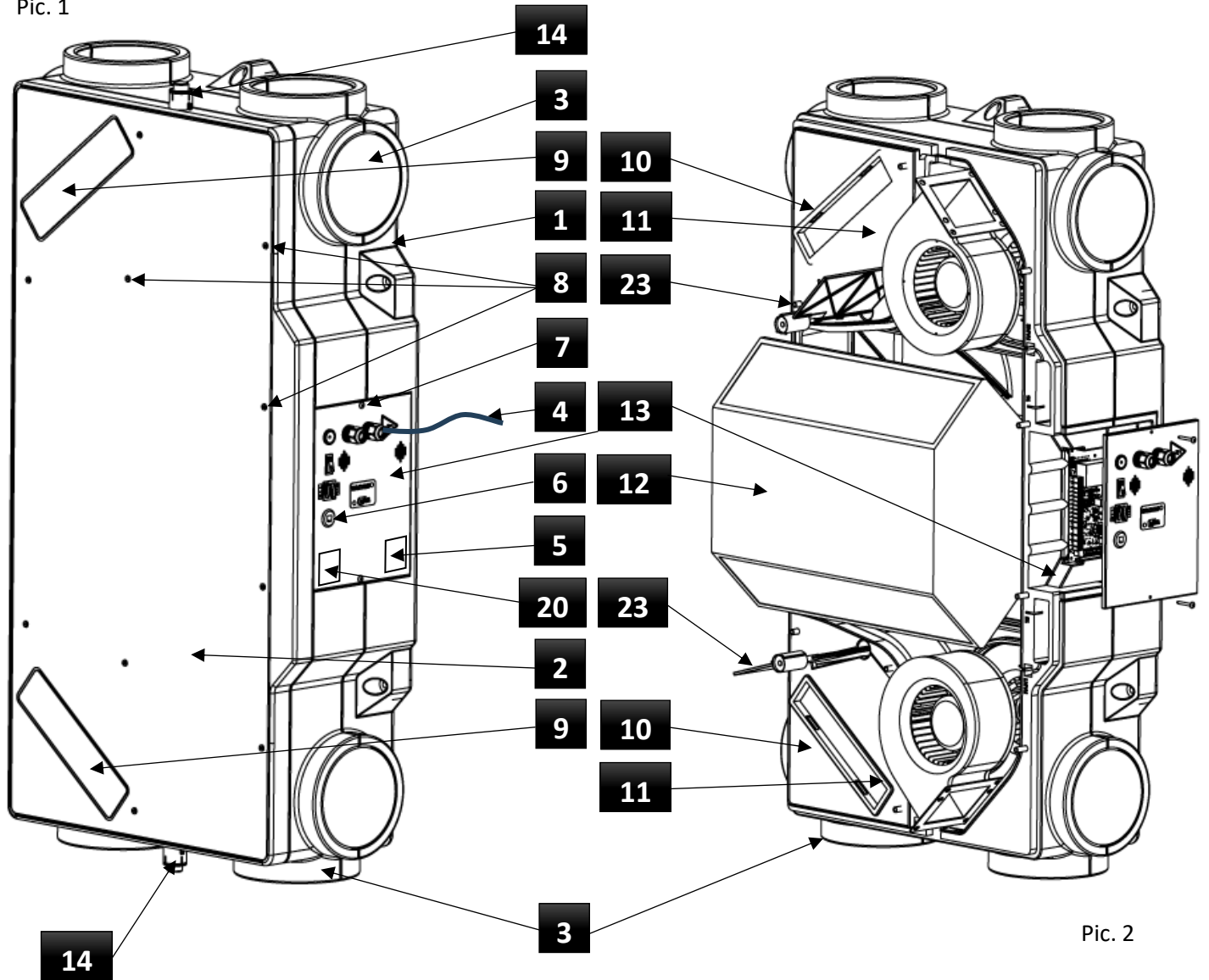

Pic. 2

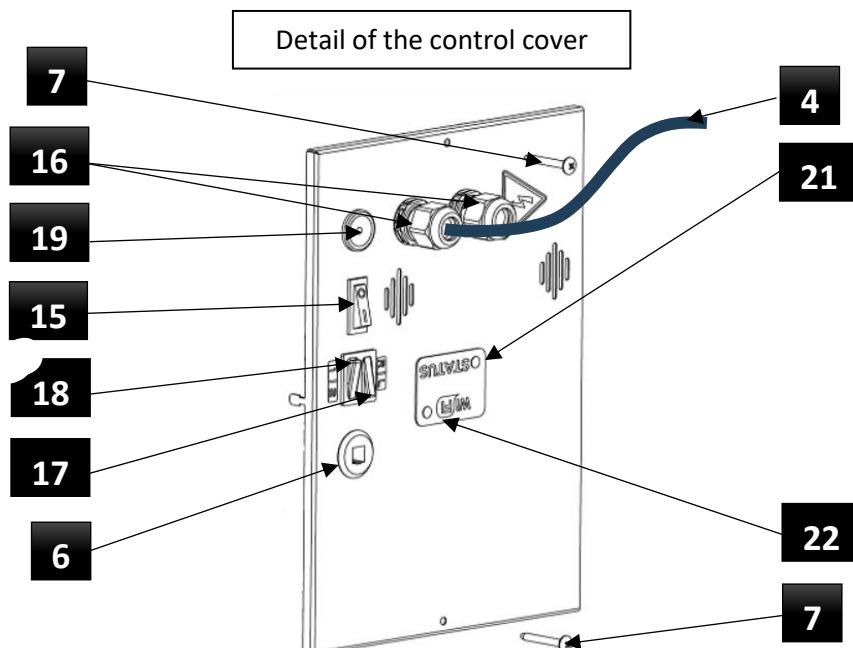

Pic.3

2.1.1. Unit casing (position 1.)

- The body of the unit is made of black molded plastic EPP (expanded polypropylene). The material itself is an advanced technical material with a unique combination of properties of strength at low weight, rebound elasticity, thermal insulation, chemical resistance, sound insulation and recyclability.

2.1.2. Unit Lid (Position 2)

- The lid of the unit is made of black molded plastic EPP (expanded polypropylene). The material itself is an advanced technical material with a unique combination of properties of strength at low weight, rebound elasticity, thermal insulation, chemical resistance, sound insulation and recyclability.

2.1.3. Connection Sockets (Position 3)

- The connection sockets $\varnothing 160/\varnothing 200$ mm (inner/outer diameter) are made of EPP material. To increase the variability of the connection, it is possible to connect ducts both in the axis of the unit and perpendicular to the unit. The connection can also be combined, **EXCEPT FOR THE SPIGOT IN WHICH THE PREHEATER IS LOCATED, IT MUST NOT BE MANIPULATED** (if the unit is equipped). This allows a direct connection of the duct to the unit without the need to use an elbow (perpendicular connection of the duct has no effect on the advertised ventilation parameters).

2.1.4. Power cord (position 4)

- It connects the unit and the connection point from the mains. Cable length approx. 1 m. CYSY cable type 3x1.5mm² with shaved and marked ends 50 mm.

2.1.5. Production Plate (Position 5)

- It displays the electrical and other technical parameters of the unit.

2.1.6. RJ connector (position 6)

- The RJ connector is used to connect the controller to the unit.

2.1.7. Self-tapping screw $\varnothing 4.2 \times 35$ (position 7.)

- Self-tapping screw (2pcs) serves to attach the cover plate of the regulation. Pozidriv size 1.

2.1.8. M6x25 Screw (Position 8)

- Galvanized screw M6x25 (10pcs) with a flat head with an internal "star" type TORX size 20.

2.1.9. Filter caps (position 9)

- The filter caps are used to seal the filters in the unit. They are made of black molded EPP (expanded polypropylene) plastic.

2.1.10. Filters (position 10)

- M5 filters (ISO ePM10 55%) are included. Filters can be supplied as accessories on request:
 - o F7 (ISO ePM1 70%) – Order Code - XF-035/045-FILTER-F7
 - o F9 (ISO ePM1 85%) - Order Code - XF-035/045-FILTER-F9
 - o G4 with an activated carbon odor layer, (ISO ePM2.5 60%) – order code XF-035/050-FILTER-G4/AC
- Filter evaluation according to ČSN EN ISO 16890

2.1.11. Fans (Position 11)

- Plastic radial fan with EC motor from the world's leading manufacturers ensures smooth operation, minimal electricity consumption, and long-term lifetime of the unit.

2.1.12. Heat exchanger (position 12.)

- The counterflow heat exchanger ensures heat recovery with maximum efficiency (XF2-035-ECxxHR, XF2-045-ECxxHR...). In the version with enthalpy heat exchanger (XF2-035-ECxxER, XF2-045-ECxxER ...) it also allows moisture to be recovered to the ventilated area.

2.1.13. Box regulation (position 13.)

- It ensures the interconnection of individual components, and at the same time allows customer to connect to the unit

2.1.14. Condensate outlet (position 14.)

- Plastic condensate drain made of ABS material. It is used to drain condensate from the unit.

2.1.15. Power switch (position 15.)

- Single-pole main switch is used to connect/disconnect the unit from the mains.

2.1.16. Screw grommet (position 16.)

- It is designed for the leading of a communication cable (e.g.: UTP) to connect the unit to the superior BMS system and the supply cable. As a standard, the cables are pulled through grommets.

2.1.17. Right/Left Version Switch (Position 17)

- Switching between the right (R-mark - factory settings) and the left (L-mark) version

2.1.18. Nominal airflow Switch (Position 18)

- Switching between two nominal airflows:
- a) XF2-035 300 and 350m³/h
- b) XF2-045 400 and 450m³/h

2.1.19. Rubber grommet (position 19)

- Rubber grommet for leading cables from peripherals (e.g.: EXT1, EXT2, AQS sensors).

2.1.20. Wifi label (position 20.)

- Wifi ID Label for Logging in to Control via Web App – APP (www.WIFImodule.eu)

2.1.21. LED status (position 21)

- Status LED indicates the operating status of the unit

2.1.22. WIFI LED (position 22)

- WIFI LED signals the connection status of the unit to the local WIFI network and the Internet for control via APP

2.1.23. Bypass flap (position 23rd)

- The unit is equipped with two bypass flaps for automatic start/stop of the free-cooling system by the difference in air temperatures between the exterior and interior. Material ABS plastic, black color

2.2. Main dimensions of the XF2-035 unit; XF2-045:

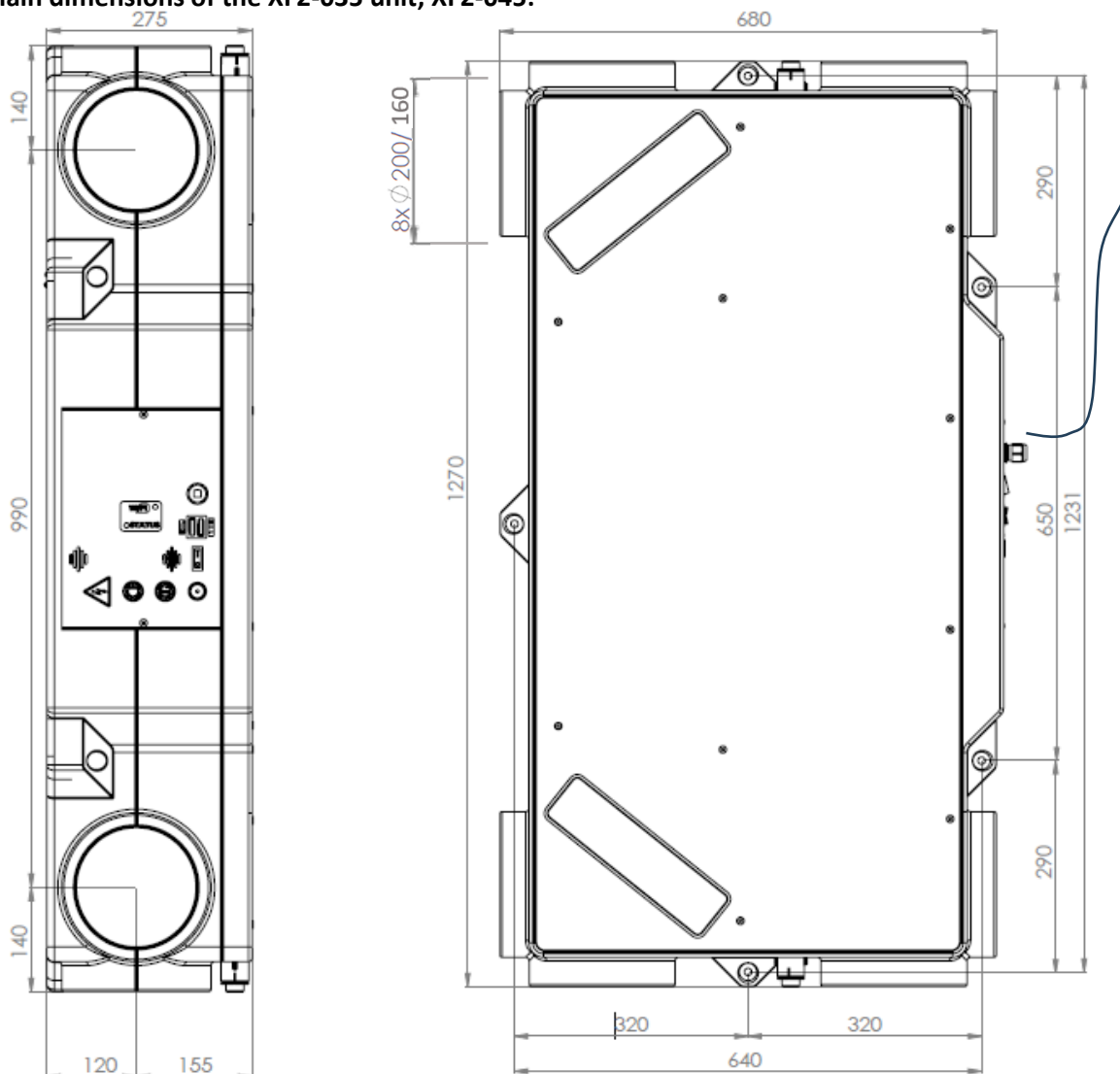

2.3. Technical parameters of Xflat units – XF2

2.3.1. Basic technical parameters

- Basic technical parameters – XF2-035; XF2-045

Tab. 1

Typ Xflat			XFLAT-350		XFLAT-450	
			XF2-035-ECS0HR XXX-1A0	XF2-035-ECS0ER XXX- 1A0	XF2-045-ECS0HR XXX-1A0	XF2-045-ECS0ER XXX- 1A0
Type of heat recovery exchanger			HRV - temperature	ERV -Temperature/ Humidity	HRV - temperature	ERV -Temperature/ Humidity
Bypass Type			Mechanical			
Nominal airflow*	m ³ /h		300/350	300/350	400/450	400/450
Acoustic level LWA (**) nominal Q at 200Pa	dB(A)		57,2 (35,6) / 58,8 (37,3)	57,2 (35,6) / 58,8 (37,3)	57,1 (35,5) / 59,3 (37,7)	57,1 (35,5) / 59,3 (37,7)
Weight***	kg		26	28	27	29
Power supply	V/ Hz		1 ~ 230 / 50-60			
Nominal input****	W		280 / 1900	280 / 1900	420 / 2050	420 / 2050
Nominal current****	A		2 / 9	2 / 9	3 / 10	3 / 10
Thermal efficiency *****	Heat	%	86,4	72	85,6	70
	Humidity	%	-	49	-	45
Internal preheater	W		1000W (+9°C)	1000W (+9°C)	1000W (+7°C)	1000W (+7°C)
Electric safety	IP		20			
Energy class (SEC) central control / demand control	-		-39,3 (A) / -42,5 (A+)	-38,8 (A) / -42,2 (A+)	-38,2 (A) / -41,8 (A)	-36,6 (A) / -40,8 (A)

* Nominal airflow at external pressure drop of 200Pa,

** Sound pressure level in free space at a distance of 3m (Q2)

*** Unit weight without packaging

**** Power consumption, current (at nominal airflow/200Pa)

***** Heat recovery efficiency stated at 70% of nominal flow according to EN 308

***** Energy Efficiency Class (SEC) – for lower/higher nominal flow rate (energy class)

Parameters SFP and SPI

Tab. 2

Unit	SFP (W/m ³ /h)	Nominal airflow - ECODESIGN (m ³ /h)	Power consumption - fan (W)	Power consumption - control (W)	Power consumption - complete unit (W)	SPI (W/m ³ /h)
XF2-035 (300m ³ /h)	0,258	210	54	3	54	0,26
XF2-035 (350m ³ /h)	0,298	245	73		73	0,30
XF2-045 (400m ³ /h)	0,293	280	82		82	0,29
XF2-045 (450m ³ /h)	0,357	315	112		112	0,36

2.3.2. Airflow curves

- **XF2-035 – nominal flow rate 300 m³/h - (output 1)**

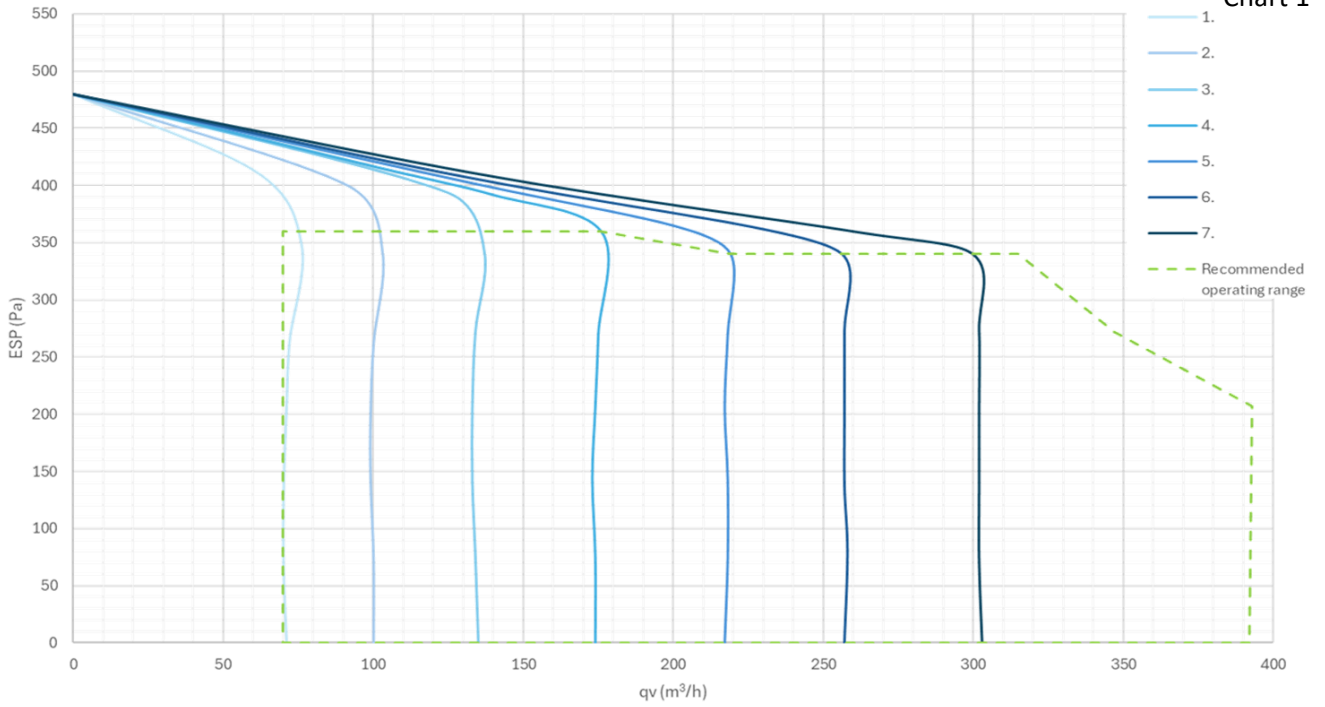

- **XF2-035 – nominal flow rate 350m³/h - (output 2)**

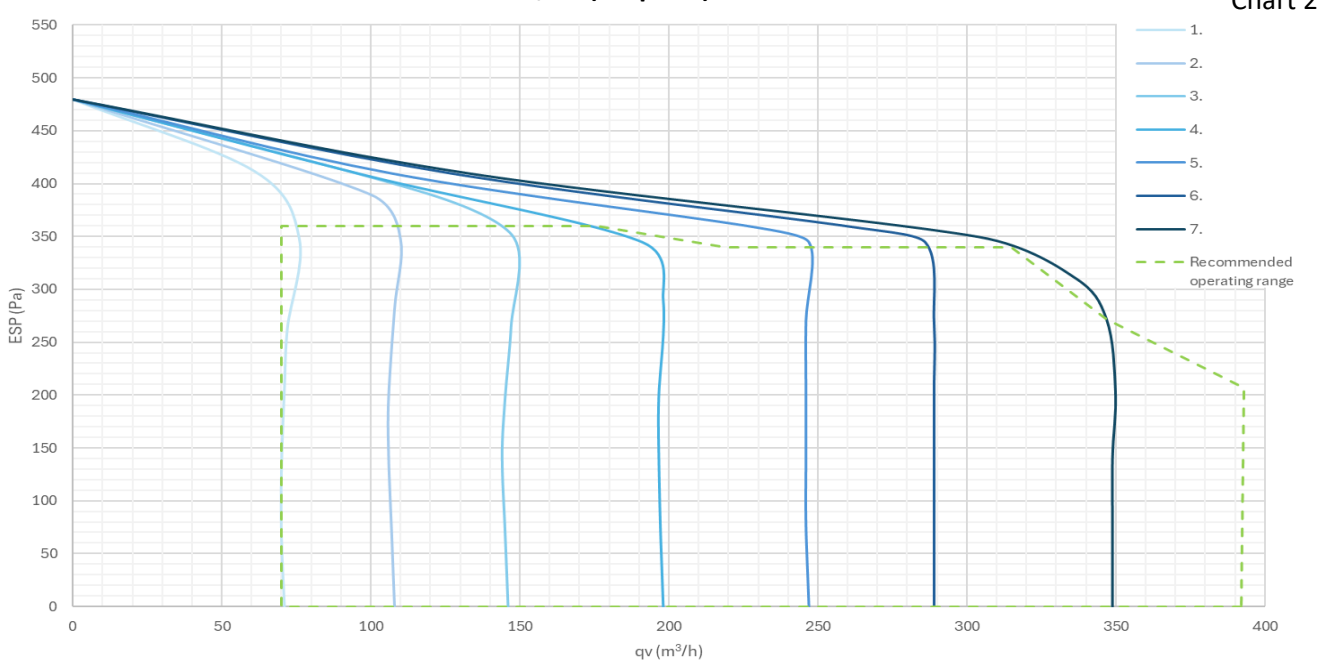

- **XF2-045 – nominal flow rate 400 m³/h - (output 1)**

Chart 3

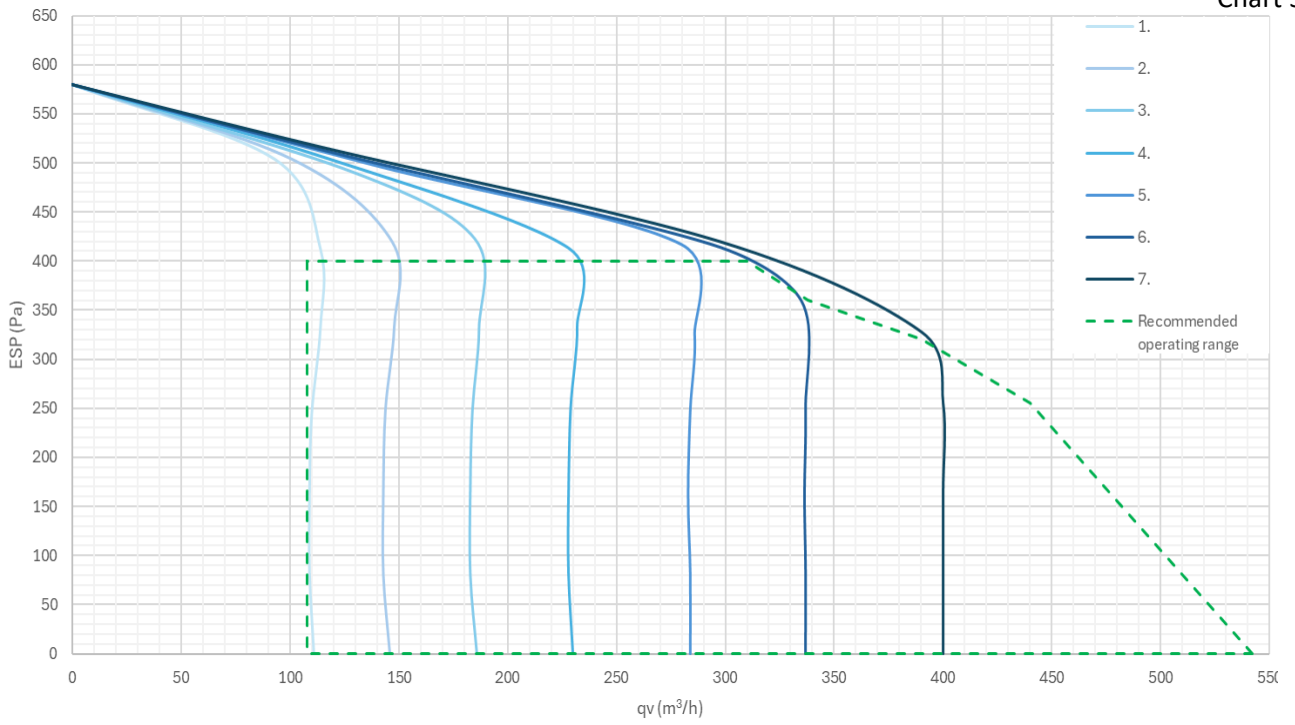

- **XF2-045 – nominal flow rate 450 m³/h - (output 2)**

Chart 4

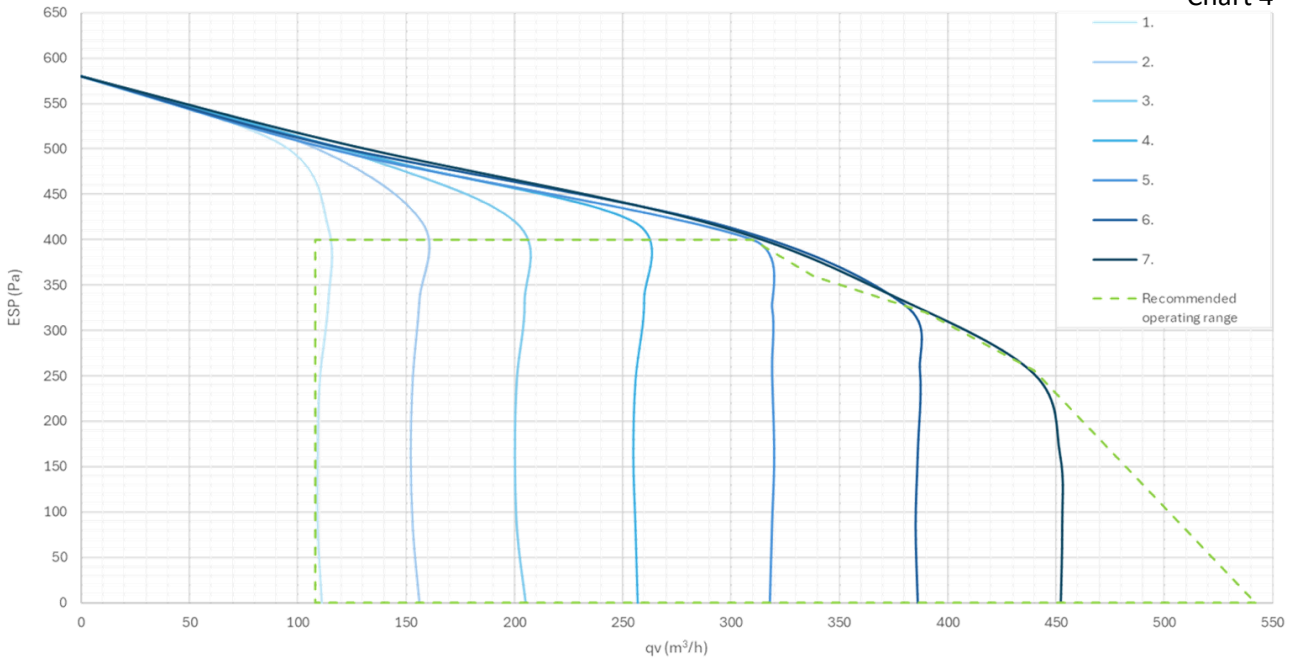

EC Declaration of Conformity – the current and full version of the EC Declaration of Conformity can be found on our website www.xvent.cz in the section "Documentation → Xflat 350-450"

2.3.3. Acoustic data XF2-035

- **XF2-035 - Nominal flow rate 300 m³/h - (capacity 1)**
 - o Radiating of the unit to the interior (inside the room)

Tab. 3

Airflow	Sound power level LWA [dB (A)]																							Sound pressure level in the open field on the reflection plane				
	50 Hz	63 Hz	80 Hz	100 Hz	125 Hz	160 Hz	200 Hz	250 Hz	315 Hz	400 Hz	500 Hz	630 Hz	800 Hz	1 k	1,25 k	1,6 k	2 k	2,5 k	3,15 k	4 k	5 k	6,3 k	8 k	10 k	L _{WA}	1 m	3 m	5 m
	(dBA)																							(dBA)	LPA (dBA)	LPA (dBA)	LPA (dBA)	
MIN / 1.	6,9	13,0	15,5	13,6	13,0	16,7	30,8	30,7	23,0	39,4	27,5	26,7	30,2	26,3	21,7	19,3	18,7	15,7	12,6	11,6	11,7	11,8	11,6	11,3	41,6	27,6	20,0	<20
MID / 4.	14,8	22,5	29,2	29,7	35,3	36,7	34,9	37,5	34,2	35,3	32,7	34,2	40,1	38,9	33,1	33,5	32,4	28,5	23,4	21,7	18,8	17,2	15,4	12,4	47,4	33,4	25,8	21,9
MAX / 7.	23,0	28,8	35,2	35,3	42,5	44,8	45,1	47,8	45,8	42,2	40,5	38,3	45,2	52,0	46,8	45,3	40,9	38,0	34,9	33,6	30,8	29,2	27,1	21,2	57,2	43,2	35,6	31,7
ECODESIGN*	15,7	21,4	26,0	28,3	34,2	35,9	35,4	37,3	34,7	35,3	32,3	37,1	39,4	38,5	32,9	32,9	31,9	28,3	23,8	21,8	19,3	17,5	15,8	12,8	47,2	33,2	25,6	21,7

*70% Nominal airflow / 50 Pa

- o Radiating of the unit into the duct – nominal air output

Tab. 4

Airflow branche	Airflow	Sound power level LWA [dB (A)]																								
		50 Hz	63 Hz	80 Hz	100 Hz	125 Hz	160 Hz	200 Hz	250 Hz	315 Hz	400 Hz	500 Hz	630 Hz	800 Hz	1 k	1,25 k	1,6 k	2 k	2,5 k	3,15 k	4 k	5 k	6,3 k	8 k	10 k	LWA
		(dBA)																							(dBA)	
ODA	MIN / 1.	13,8	19,8	19,6	26,5	25,7	19,6	22,5	21,6	14,7	25,8	16,6	18,1	15,5	12,9	7,7	4,0	6,9	3,7	1,9	1,0	0,4	1,9	3,5	4,8	33,1
	MID / 4.	25,6	32,8	37,5	46,4	50,7	38,5	40,9	38,7	30,5	31,4	27,5	31,7	30,4	29,4	20,1	18,0	23,8	19,4	16,1	12,2	8,7	7,9	13,7	6,6	53,0
	MAX / 7.	32,6	40,2	43,9	53,3	56,3	50,8	53,0	51,3	43,5	42,7	36,7	39,0	37,7	38,9	31,2	28,4	32,6	30,1	28,1	25,6	21,0	20,1	26,3	16,8	60,8
	ECODESIGN*	26,9	32,9	35,7	47,3	46,5	38,0	41,5	39,0	31,3	32,8	29,0	34,9	32,2	29,9	21,5	19,1	24,2	20,8	17,2	13,8	9,3	8,4	13,7	7,8	51,6
SUP	MIN / 1.	23,8	30,1	24,6	27,9	27,0	21,9	25,5	27,0	26,6	32,3	29,0	21,9	22,4	23,1	24,8	23,2	22,3	18,8	18,0	17,4	13,9	12,1	8,2	6,6	39,1
	MID / 4.	41,3	48,9	45,1	50,7	52,2	47,0	49,5	50,4	47,9	46,8	45,4	40,5	43,7	47,0	46,6	45,5	47,6	43,9	44,4	43,7	41,0	39,9	35,5	31,8	60,5
	MAX / 7.	44,9	54,9	54,0	56,8	58,9	56,9	60,1	62,1	59,8	57,5	53,7	48,6	50,5	52,6	57,4	57,9	55,4	53,1	55,7	55,3	52,6	51,9	48,2	45,3	70,0
	ECODESIGN*	38,9	46,9	44,2	50,4	49,7	45,8	48,0	49,3	47,5	47,3	45,2	40,4	44,2	44,9	45,3	44,6	46,6	43,1	43,9	42,6	39,8	38,7	34,1	30,0	59,4
ETA	MIN / 1.	13,7	19,5	19,9	25,8	24,9	19,1	22,2	20,3	14,8	28,3	17,6	18,2	15,4	13,4	8,0	3,8	6,2	4,0	2,9	1,4	0,3	2,0	4,0	4,9	33,4
	MID / 4.	27,4	34,8	38,2	47,8	50,1	41,1	42,5	40,4	32,4	33,2	28,8	33,4	32,2	30,3	23,5	20,9	25,8	21,2	17,3	14,4	9,9	9,1	12,6	7,3	53,5
	MAX / 7.	32,8	38,8	43,2	52,9	55,6	51,1	52,3	51,7	43,0	42,4	36,4	39,1	37,7	37,1	31,2	29,0	33,5	29,6	27,7	25,5	21,1	20,5	24,7	15,3	60,4
	ECODESIGN*	25,7	31,5	34,7	47,4	47,1	38,6	41,8	39,3	31,2	32,3	28,5	33,3	31,9	29,3	20,1	24,8	20,3	17,3	14,2	10,0	9,2	11,8	7,0	51,8	
EHA	MIN / 1.	24,8	29,8	25,3	28,1	27,7	22,6	25,4	27,4	26,5	30,9	28,4	23,5	22,4	22,8	24,3	22,8	22,3	18,7	17,6	16,2	13,2	11,8	7,8	6,4	38,9
	MID / 4.	41,2	47,6	45,1	50,6	52,0	46,5	48,6	49,4	47,9	46,0	45,5	38,9	42,3	46,2	47,4	46,3	47,7	43,9	44,5	44,6	41,9	40,9	36,9	33,0	60,2
	MAX / 7.	44,3	53,2	53,3	56,0	57,7	55,9	58,8	61,2	59,4	56,0	53,4	47,2	49,1	52,1	57,0	57,6	55,6	53,7	56,0	55,6	52,8	52,7	49,5	47,0	69,4
	ECODESIGN*	38,8	44,5	42,4	49,4	49,0	45,4	48,0	48,8	47,2	45,5	44,9	38,5	43,2	44,7	46,1	45,6	46,8	42,8	43,8	43,5	40,5	39,3	35,3	31,4	59,0

- **XF2-035 - Nominal flow rate 350 m³/h - (output 2)**

- o Radiating of the unit to the interior (inside the room)

Tab. 5

Airflow	Sound power level LWA [dB (A)]																							Sound pressure level in the open field on the reflection plane				
	50 Hz	63 Hz	80 Hz	100 Hz	125 Hz	160 Hz	200 Hz	250 Hz	315 Hz	400 Hz	500 Hz	630 Hz	800 Hz	1 k	1,25 k	1,6 k	2 k	2,5 k	3,15 k	4 k	5 k	6,3 k	8 k	10 k	L _{WA}	1 m	3 m	5 m
	(dBA)																							(dBA)	LPA (dBA)	LPA (dBA)	LPA (dBA)	
MIN / 1.	6,9	13,0	15,5	13,6	13,0	16,7	30,8	30,7	23,0	39,4	27,5	26,7	30,2	26,3	21,7	19,3	18,7	15,7	12,6	11,6	11,7	11,8	11,6	11,3	41,6	27,6	20,0	<20
MID / 4.	16,6	24,3	27,9	29,7	36,1	37,7	37,3	38,9	36,4	33,9	33,9	32,7	40,7	39,5	35,6	35,0	34,0	30,6	25,9	24,0	21,5	19,4	17,7	13,3	48,3	34,3	26,8	22,8
MAX / 7.	25,2	31,4	38,2	37,5	44,6	46,5	47,5	51,6	48,8	44,3	43,3	40,7	46,7	50,3	49,2	47,5	43,0	39,8	37,2	36,0	33,3	31,8	29,9	23,8	58,8	44,8	37,3	33,3
ECODESIGN*	14,2	23,4	28,3	29,6	36,3	38,0	37,5	40,4	37,0	35,9	34,4	33,8	41,6	40,0	34,9	35,2	34,0	30,6	26,9	24,6	21,6	19,9	18,1	13,5	49,0	35,0	27,4	23,4

*70% Nominal airflow / 50 Pa

○ Radiating of the unit into the duct – nominal air output

Tab. 6

Airflow branche	Airflow	Sound power level LWA [dB (A)]																								
		50 Hz	63 Hz	80 Hz	100 Hz	125 Hz	160 Hz	200 Hz	250 Hz	315 Hz	400 Hz	500 Hz	630 Hz	800 Hz	1 k	1,25 k	1,6 k	2 k	2,5 k	3,15 k	4 k	5 k	6,3 k	8 k	10 k	LWA
		(dBA)																							(dBA)	
ODA	MIN / 1.	13,8	19,8	19,6	26,5	25,7	19,6	22,5	21,6	14,7	25,8	16,6	18,1	15,5	12,9	7,7	4,0	6,9	3,7	1,9	1,0	0,4	1,9	3,5	4,8	33,1
	MID / 4.	28,2	35,7	37,9	47,7	49,8	41,1	43,9	41,5	33,2	34,0	30,5	34,3	33,0	31,6	23,2	20,9	26,0	23,0	19,2	16,0	11,7	10,6	16,3	8,9	53,6
	MAX / 7.	34,7	41,0	45,4	54,2	55,8	51,7	54,8	53,1	46,5	45,5	38,8	40,9	39,2	47,0	40,5	31,0	34,7	32,2	30,6	28,3	24,2	23,1	29,8	20,1	61,8
	ECODESIGN*	27,3	34,8	37,4	48,0	49,6	41,4	44,5	42,3	34,3	35,1	30,9	35,0	33,8	31,6	23,5	21,4	26,3	23,5	20,4	17,2	12,6	11,4	17,2	9,5	53,8
SUP	MIN / 1.	23,8	30,1	24,6	27,9	27,0	21,9	25,5	27,0	26,6	32,3	29,0	21,9	22,4	23,1	24,8	23,2	22,3	18,8	18,0	17,4	13,9	12,1	8,2	6,6	39,1
	MID / 4.	41,0	48,4	45,3	51,0	52,6	48,3	50,4	51,6	49,3	48,0	46,0	41,8	44,6	47,4	47,6	46,7	48,4	45,2	46,1	45,1	42,3	41,3	37,0	33,4	61,3
	MAX / 7.	45,1	55,9	55,0	58,4	59,7	58,1	61,8	64,3	62,5	60,5	56,7	52,1	52,1	54,9	58,8	60,6	58,4	55,6	58,2	57,9	55,9	55,0	51,3	48,2	72,1
	ECODESIGN*	40,5	50,3	46,2	51,0	53,4	49,2	51,1	52,9	51,0	49,7	47,4	43,1	45,9	47,7	48,4	47,6	49,0	46,4	48,1	46,6	43,9	43,1	38,7	34,8	62,4
ETA	MIN / 1.	13,7	19,5	19,9	25,8	24,9	19,1	22,2	20,3	14,8	28,3	17,6	18,2	15,4	13,4	8,0	3,8	6,2	4,0	2,9	1,4	0,3	2,0	4,0	4,9	33,4
	MID / 4.	27,8	35,8	37,3	47,8	50,0	41,8	43,9	41,7	33,2	33,9	29,6	34,2	32,7	30,6	24,5	21,9	26,8	22,5	18,9	15,9	11,5	10,7	14,2	7,8	53,7
	MAX / 7.	34,9	40,6	45,5	54,5	56,0	53,1	55,4	53,8	46,7	45,5	39,1	41,0	39,4	41,8	36,6	31,5	35,8	31,7	30,4	28,2	24,6	23,9	28,1	18,5	62,2
	ECODESIGN*	26,6	33,6	37,0	48,1	50,7	41,6	44,7	43,2	34,4	35,1	30,6	34,5	33,4	30,8	24,4	22,4	27,2	22,9	20,1	16,9	12,7	11,8	15,4	8,3	54,3
EHA	MIN / 1.	24,8	29,8	25,3	28,1	27,7	22,6	25,4	27,4	26,5	30,9	28,4	23,5	22,4	22,8	24,3	22,8	22,3	18,7	17,6	16,2	13,2	11,8	7,8	6,4	38,9
	MID / 4.	41,5	47,6	43,5	50,1	51,1	47,5	49,9	51,1	48,9	46,8	46,2	40,0	43,2	46,8	48,3	47,4	48,8	45,3	45,9	45,8	43,0	42,0	38,2	34,5	60,8
	MAX / 7.	46,0	54,7	55,7	58,2	59,0	57,6	61,6	64,3	63,2	59,9	56,7	50,5	51,1	56,1	58,6	60,3	58,3	55,7	58,6	58,3	55,6	55,4	52,3	49,9	72,1
	ECODESIGN*	40,1	47,8	45,2	50,6	51,1	48,0	50,7	52,5	50,8	48,3	47,2	41,1	44,4	47,1	48,7	47,9	49,3	46,2	47,5	46,9	44,2	43,2	39,5	35,9	61,7

2.3.4. Acoustic data XF2-045

- XF2-045 - Nominal flow rate 400 m³/h - (output 1)

○ Radiating of the unit to the interior (inside the room)

Tab. 7

Airflow	Sound power level LWA [dB (A)]																							Sound pressure level in the open field on the reflection plane				
	50 Hz	63 Hz	80 Hz	100 Hz	125 Hz	160 Hz	200 Hz	250 Hz	315 Hz	400 Hz	500 Hz	630 Hz	800 Hz	1 k	1,25 k	1,6 k	2 k	2,5 k	3,15 k	4 k	5 k	6,3 k	8 k	10 k	L _{WA}	1 m	3 m	5 m
	(dBA)																							(dBA)	LPA (dBA)	LPA (dBA)	LPA (dBA)	
MIN / 1.	11,1	15,3	19,3	19,4	21,6	21,6	24,6	27,7	28,4	39,3	29,9	28,0	32,0	29,7	27,2	23,2	20,5	14,8	13,1	12,1	11,4	11,9	11,6	11,4	41,9	27,9	20,4	<20
MID / 4.	16,3	21,6	25,8	27,7	34,4	35,2	36,5	40,0	38,8	37,4	35,3	36,8	41,4	40,5	37,9	35,5	34,1	31,4	26,6	25,1	23,2	22,1	19,3	14,4	49,2	35,2	27,6	23,7
MAX / 7.	22,3	27,7	33,2	35,0	40,8	42,5	44,4	48,5	46,8	43,8	43,8	43,5	47,6	47,1	46,5	47,4	43,3	41,2	36,8	35,4	33,6	32,8	30,1	23,8	57,1	43,1	35,5	31,5
ECODESIGN*	16,6	22,0	27,3	27,2	33,9	35,6	36,2	39,8	38,8	36,4	35,5	37,4	40,8	40,3	37,5	34,9	33,5	30,9	26,3	24,6	22,6	21,5	18,6	14,1	48,9	34,9	27,4	23,4

*70% Nominal airflow / 50 Pa

○ Radiating of the unit into the duct – nominal air output

Tab. 8

Airflow branche	Airflow	Sound power level LWA [dB (A)]																								
		50 Hz	63 Hz	80 Hz	100 Hz	125 Hz	160 Hz	200 Hz	250 Hz	315 Hz	400 Hz	500 Hz	630 Hz	800 Hz	1 k	1,25 k	1,6 k	2 k	2,5 k	3,15 k	4 k	5 k	6,3 k	8 k	10 k	LWA
		(dBA)																							(dBA)	
ODA	MIN / 1.	17,2	24,8	24,5	33,1	32,2	24,5	28,1	27,0	18,3	32,2	20,7	22,6	19,3	16,2	9,6	5,0	8,6	4,7	2,4	1,3	0,6	2,3	4,4	6,0	39,0
	MID / 4.	28,5	36,5	37,1	45,3	46,3	40,6	43,8	42,6	36,1	36,7	32,0	36,3	33,8	32,1	25,0	22,4	25,4	22,9	19,0	17,3	12,8	11,4	15,4	8,4	52,1
	MAX / 7.	35,5	41,5	42,8	52,2	53,2	49,6	52,0	50,5	45,0	45,1	40,5	43,8	40,4	38,1	33,2	33,7	34,3	32,6	29,4	27,8	23,7	23,0	27,4	17,0	59,5
	ECODESIGN*	26,8	32,8	35,0	44,8	45,8	39,7	43,6	42,3	35,8	36,4	32,0	36,3	33,4	32,6	24,6	21,8	24,7	22,2	18,5	17,0	12,1	10,8	14,9	8,3	51,5
SUP	MIN / 1.	29,8	37,6	30,7	34,9	33,7	27,4	31,9	33,8	33,2	40,3	36,3	27,4	27,9	28,9	31,0	28,9	27,9	23,5	22,4	21,7	17,3	15,1	10,2	8,2	46,0
	MID / 4.	39,8	47,5	43,5	47,1	47,9	46,5	50,9	52,8	52,2	51,7	48,2	43,9	44,4	49,3	50,0	47,2	48,6	45,7	45,9	45,3	44,2	44,1	39,0	34,9	61,7
	MAX / 7.	46,1	53,8	51,6	55,8	55,9	54,4	58,7	61,0	61,8	61,6	57,6	53,7	52,0	54,6	59,9	59,6	58,8	56,0	57,1	56,2	55,2	55,4	51,5	48,3	71,0
	ECODESIGN*	38,9	47,0	43,8	47,6	48,5	46,8	51,1	51,3	51,7	52,3	48,7	44,5	44,4	47,0	49,7	47,1	48,5	45,9	46,0	45,8	44,4	44,4	39,4	35,4	61,5
ETA	MIN / 1.	17,2	24,4	24,8	32,3	31,1	23,9	27,8	25,4	18,5	35,4	22,0	22,7	19,3	16,8	10,0	4,7	7,7	5,0	3,7	1,7	0,3	2,5	5,0	6,1	39,5
	MID / 4.	28,5	34,4	35,7	45,6	46,8	40,0	42,3	43,0	35,5	35,9	32,3	35,7	34,2	30,7	25,1	21,8	25,7	22,6	18,4	17,4	14,9	13,7	16,4	8,9	51,9
	MAX / 7.	35,9	40,8	42,5	53,2	53,3	49,1	51,2	51,2	44,4	44,9	41,1	43,6	41,2	37,8	33,6	32,4	35,1	32,3	29,0	28,0	23,8	24,3	27,5	17,9	59,7
	ECODESIGN*	26,4	30,6	33,3	45,8	46,6	39,5	41,8	42,8	35,3	35,9	32,6	35,5	33,8	30,5	24,7	21,3	25,4	22,1	18,1	17,4	13,0	13,5	16,0	8,7	51,7
EHA	MIN / 1.	31,0	37,3	31,7	35,1	34,6	28,3	31,8	34,3	33,1	38,7	35,5	29,4	27,9	28,5	30,4	28,5	27,9	23,4	22,0	20,2	16,5	14,7	9,7	8,1	45,7
	MID / 4.	38,9	46,4	42,2	47,0	48,3	46,7	50,0	52,5	52,1	51,5	48,0	43,9	44,7	47,3	49,7	47,4	48,3	45,6	45,9	45,4	44,1	43,7	38,4	33,8	61,4
	MAX / 7.	45,2	52,9	49,9	55,2	55,5	54,0	58,0	61,7	61,2	60,8	57,3	53,3	52,2	54,8	60,0	60,2	58,5	56,1	57,3	56,5	55,4	55,8	51,5	48,2	70,9
	ECODESIGN*	37,4	45,2	41,4	47,5	48,4	46,2	49,8	52,0	51,8	51,3	48,0	43,8	44,4	46,2	48,9	46,6	47,6	44,8	45,2	44,7	43,4	42,9	37,7	33,2	60,9

*70% Nominal airflow / 50 Pa

- **XF2-045 - Nominal flow rate 450 m³/h - (output 2)**

- Radiating of the unit to the interior (inside the room)

Tab. 9

Airflow	Sound power level LWA [dB (A)]																					Sound pressure level in the open field on the reflection plane						
	50 Hz	63 Hz	80 Hz	100 Hz	125 Hz	160 Hz	200 Hz	250 Hz	315 Hz	400 Hz	500 Hz	630 Hz	800 Hz	1 k	1,25 k	1,6 k	2 k	2,5 k	3,15 k	4 k	5 k	6,3 k	8 k	10 k	L _{WA}	1 m	3 m	5 m
	(dBA)																								(dBA)	LPA (dBA)	LPA (dBA)	LPA (dBA)
MIN / 1.	11,1	15,3	19,3	19,4	21,6	21,6	24,6	27,7	28,4	39,3	29,9	28,0	32,0	29,7	27,2	23,2	20,5	14,8	13,1	12,1	11,4	11,9	11,6	11,4	41,9	27,9	20,4	<20
MID / 4.	17,0	23,6	27,4	29,4	35,8	38,4	39,5	43,2	41,1	40,5	37,8	39,2	43,9	42,2	41,7	38,9	37,1	34,6	30,0	28,5	26,5	25,6	22,9	16,8	51,9	37,9	30,4	26,4
MAX / 7.	25,1	28,7	34,2	37,1	44,4	44,9	46,8	51,0	48,9	46,2	45,7	46,0	49,4	49,1	48,4	49,3	45,9	43,5	39,2	37,8	35,9	35,0	32,7	26,5	59,3	45,3	37,7	33,8
ECODESIGN*	13,9	23,5	27,8	29,7	36,3	38,0	38,7	42,1	40,5	38,9	37,6	39,7	43,2	42,1	39,9	37,6	36,0	33,5	29,0	27,4	25,4	24,6	21,5	15,9	51,2	37,2	29,6	25,7

*70% Nominal airflow / 50 Pa

- Radiating of the unit into the duct – nominal air output

Tab. 10

Airflow branche	Airflow	Sound power level LWA [dB (A)]																					LWA			
		50 Hz	63 Hz	80 Hz	100 Hz	125 Hz	160 Hz	200 Hz	250 Hz	315 Hz	400 Hz	500 Hz	630 Hz	800 Hz	1 k	1,25 k	1,6 k	2 k	2,5 k	3,15 k	4 k	5 k		6,3 k	8 k	10 k
		(dBA)																								(dBA)
ODA	MIN / 1.	17,2	24,8	24,5	33,1	32,2	24,5	28,1	27,0	18,3	32,2	20,7	22,6	19,3	16,2	9,6	5,0	8,6	4,7	2,4	1,3	0,6	2,3	4,4	6,0	39,0
	MID / 4.	30,5	38,3	38,8	47,1	48,3	42,3	46,3	45,2	39,1	39,5	34,7	38,6	36,0	33,9	28,7	25,1	28,5	26,2	22,6	21,0	16,5	15,4	19,7	11,3	54,2
	MAX / 7.	38,1	42,7	44,2	54,0	54,9	51,0	53,9	53,0	47,1	47,2	42,6	45,8	42,4	40,3	34,9	34,1	36,5	34,7	31,9	30,3	26,1	25,2	30,3	19,9	61,4
	ECODESIGN*	28,2	34,8	37,6	47,0	48,2	42,5	45,9	44,9	38,5	39,0	34,4	38,3	35,5	33,1	26,7	24,2	27,2	24,9	21,4	19,8	15,1	14,1	18,3	10,2	53,9
SUP	MIN / 1.	29,8	37,6	30,7	34,9	33,7	27,4	31,9	33,8	33,2	40,3	36,3	27,4	27,9	28,9	31,0	28,9	27,9	23,5	22,4	21,7	17,3	15,1	10,2	8,2	46,0
	MID / 4.	40,6	49,5	45,8	50,6	50,4	49,3	53,4	55,7	55,6	55,2	51,5	47,3	46,5	52,2	55,2	50,7	51,9	49,4	49,6	49,3	48,1	48,4	43,6	39,9	65,0
	MAX / 7.	50,0	54,6	52,7	58,4	58,3	56,4	60,8	63,3	63,7	63,9	60,4	56,4	54,5	57,1	61,8	62,7	61,8	58,8	59,7	59,0	57,9	58,3	54,4	51,3	73,4
	ECODESIGN*	39,7	50,1	46,7	51,2	51,0	49,3	53,2	55,5	55,2	55,0	51,3	47,3	46,4	51,3	52,5	49,7	51,1	48,4	48,8	48,5	47,3	47,3	42,5	38,8	64,5
ETA	MIN / 1.	17,2	24,4	24,8	32,3	31,1	23,9	27,8	25,4	18,5	35,4	22,0	22,7	19,3	16,8	10,0	4,7	7,7	5,0	3,7	1,7	0,3	2,5	5,0	6,1	39,5
	MID / 4.	30,2	36,7	37,0	48,3	48,3	42,3	44,8	45,6	38,4	39,2	35,1	38,3	36,2	33,3	28,6	24,5	29,0	25,8	21,9	21,0	17,3	17,5	20,1	11,6	54,2
	MAX / 7.	39,0	42,5	44,1	54,6	55,1	50,7	52,9	53,5	46,4	47,3	43,4	45,7	42,9	39,7	35,6	34,2	37,7	34,5	31,5	30,4	26,6	26,8	30,1	20,5	61,5
	ECODESIGN*	28,1	31,4	36,1	48,6	48,7	41,8	44,5	45,3	37,8	38,6	34,9	37,9	35,8	32,2	26,8	23,5	27,6	24,7	20,8	20,0	15,7	16,0	18,8	10,3	54,2
EHA	MIN / 1.	31,0	37,3	31,7	35,1	34,6	28,3	31,8	34,3	33,1	38,7	35,5	29,4	27,9	28,5	30,4	28,5	27,9	23,4	22,0	20,2	16,5	14,7	9,7	8,1	45,7
	MID / 4.	40,0	48,3	44,8	50,1	50,7	48,9	53,0	55,4	55,1	54,9	51,2	47,1	47,0	50,4	53,4	50,7	51,6	48,4	50,0	48,9	48,8	48,2	43,4	39,0	64,5
	MAX / 7.	47,7	54,5	51,2	57,2	57,6	56,2	60,4	63,5	63,3	63,1	59,7	56,0	54,5	57,0	61,8	62,5	61,4	58,5	59,8	59,1	58,1	58,2	54,0	51,0	73,1
	ECODESIGN*	39,3	48,7	45,5	50,2	51,4	48,9	52,6	55,0	54,7	54,3	50,9	46,9	46,6	49,3	52,0	49,6	50,6	48,0	48,6	48,0	46,8	46,6	41,8	37,6	63,9

*70% Nominal airflow / 50 Pa

2.3.5. Heat and Moisture Recovery Efficiency – XF2-035

- XF2-035 - Nominal flow rate 300 m³/h - (output 1)

Tab. 11

Commercial name		XFLAT-350 (nominal 300m ³ /h)								
Unit type		XF2-035-ECS0HRXXX-1A0				XF2-035-ECS0ERXXX-1A0				
Nominal output		300m ³ /h				300m ³ /h				
Type of recuperator		HRV - temperature				ERV - temperature/humidity				
		Flow rate (m ³ /h)	Temperature % efficiency (EN308)	Current (A)	Power supply (W)	Flow rate (m ³ /h)	Temperature % efficiency (EN308)	Humidity efficiency % (EN308)	Current (A)	Power supply (W)
Airflow level	1	70	91,9	0,10	9	70	78,9	61,2	0,10	9
	2	100	91,3	0,15	14	100	77,3	58,7	0,15	14
	3	133	90,7	0,30	20	133	75,8	56,3	0,30	20
	4	174	90,1	0,55	32	174	74,2	53,7	0,55	32
	5	218	89,5	0,85	61	218	72,7	51,3	0,85	61
	6	257	88,9	0,99	121	257	71,3	49,1	0,99	121
	7*	300	88,4	1,12	165	300	69,8	46,4	1,12	165
	Boost**	350	87,7	1,26	179	350	68	43,8	1,26	179
	ECODESIGN***	210	89,5	0,34	54	210	73	51,7	0,34	54

* Nominal airflow at an external pressure drop of 200 Pa

** BOOST mode – intensive ventilation for a set period of time

*** 70% of nominal airflow / 50 Pa

Chart 5

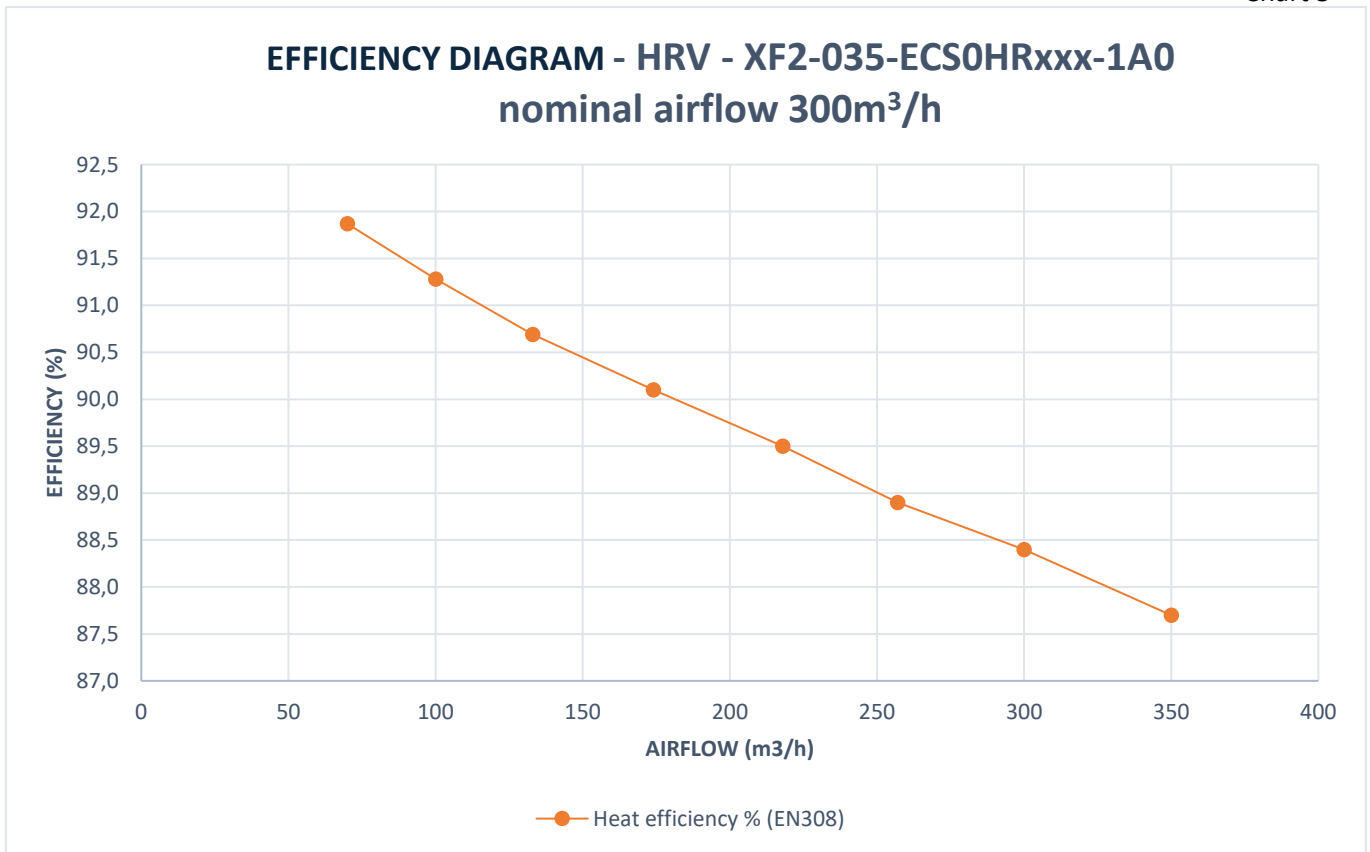
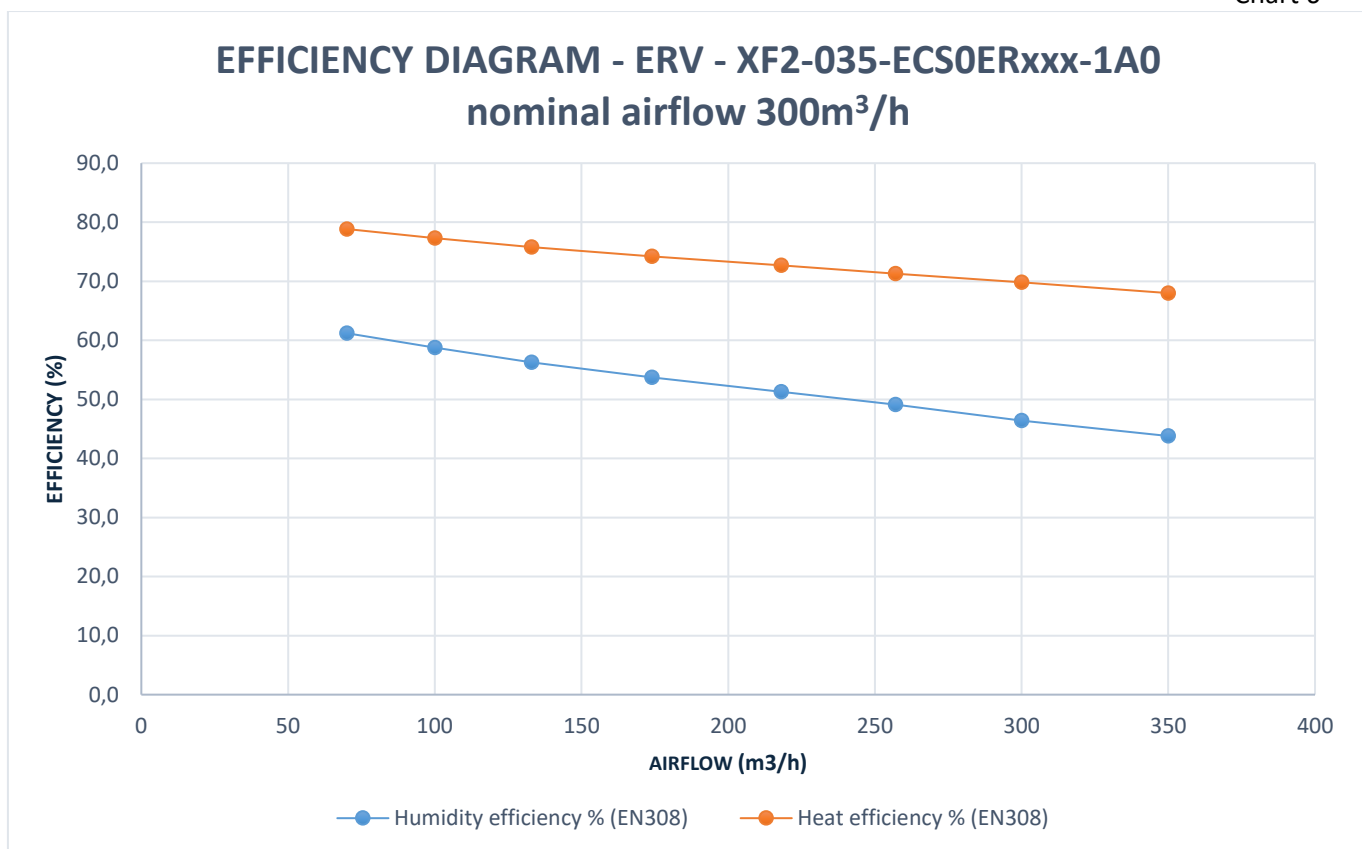

Chart 6



- XF2-035 - Nominal flow rate 350 m³/h - (output 2)

Table 12

Commercial name		XFLAT-350 (nominal 350m ³ /h)								
Unit type		XF2-035-ECS0HRXXX-1A0				XF2-035-ECS0ERXXX-1A0				
Nominal output		350m ³ /h				350m ³ /h				
Type of recuperator		HRV - temperature				ERV - temperature/humidity				
		Flow rate (m ³ /h)	Temperature % efficiency (EN308)	Current (A)	Power supply (W)	Flow rate (m ³ /h)	Temperature % efficiency (EN308)	Humidity efficiency % (EN308)	Current (A)	Power supply (W)
Airflow level	1	70	91,7	0,10	9	70	78,5	60,5	0,10	9
	2	105	91,0	0,16	15	105	76,8	57,8	0,16	15
	3	145	90,4	0,35	22	145	75	55	0,35	22
	4	198	89,7	0,65	38	198	73,4	52,4	0,65	38
	5	246	89,1	0,90	115	246	71,7	49,7	0,90	115
	6	290	88,5	1,08	160	290	70	47	1,08	160
	7*	350	87,7	1,26	179	350	68	43,8	1,26	179
	Boost**	390	87,2	1,85	270	390	66,5	41,6	1,85	270
	ECODESIGN***	245	89,1	0,55	66	245	71,7	49,7	0,55	66

* Nominal airflow at an external pressure drop of 200 Pa

** BOOST mode – intensive ventilation for a set period of time

*** 70% of nominal airflow / 50 Pa

Chart 7

EFFICIENCY DIAGRAM - HRV - XF2-035-ECS0HRxxx-1A0
nominal airflow 350m³/h

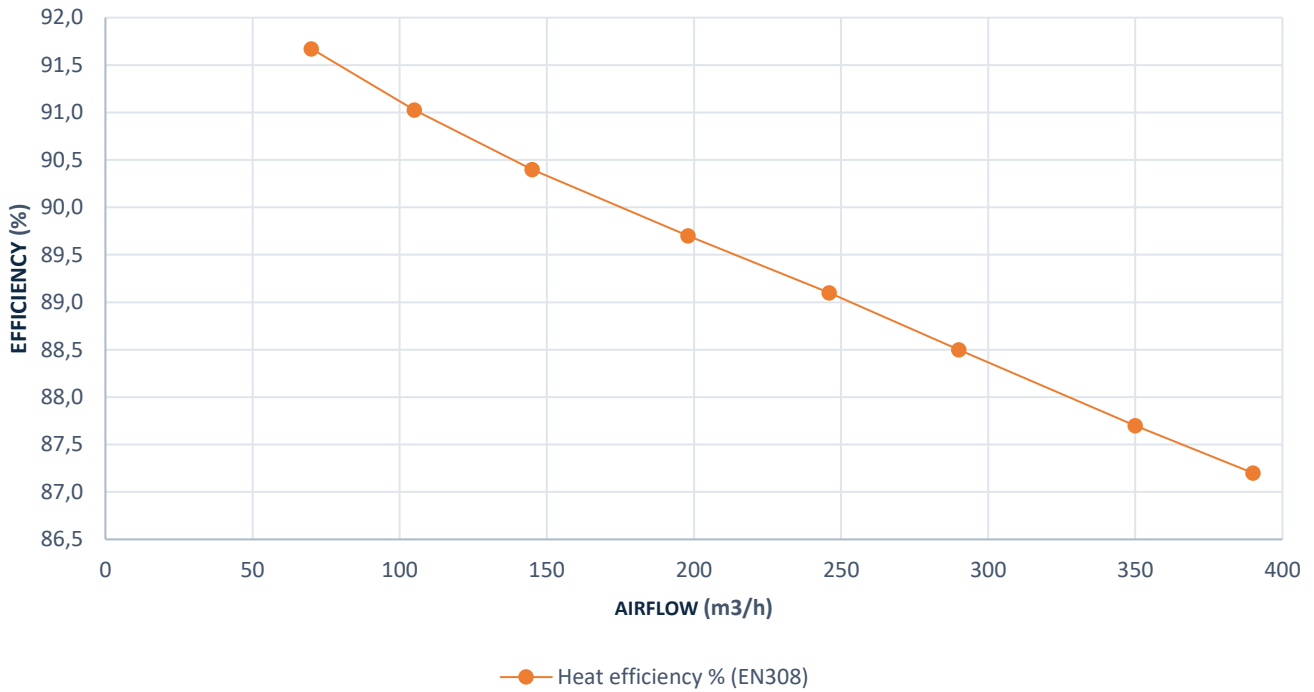
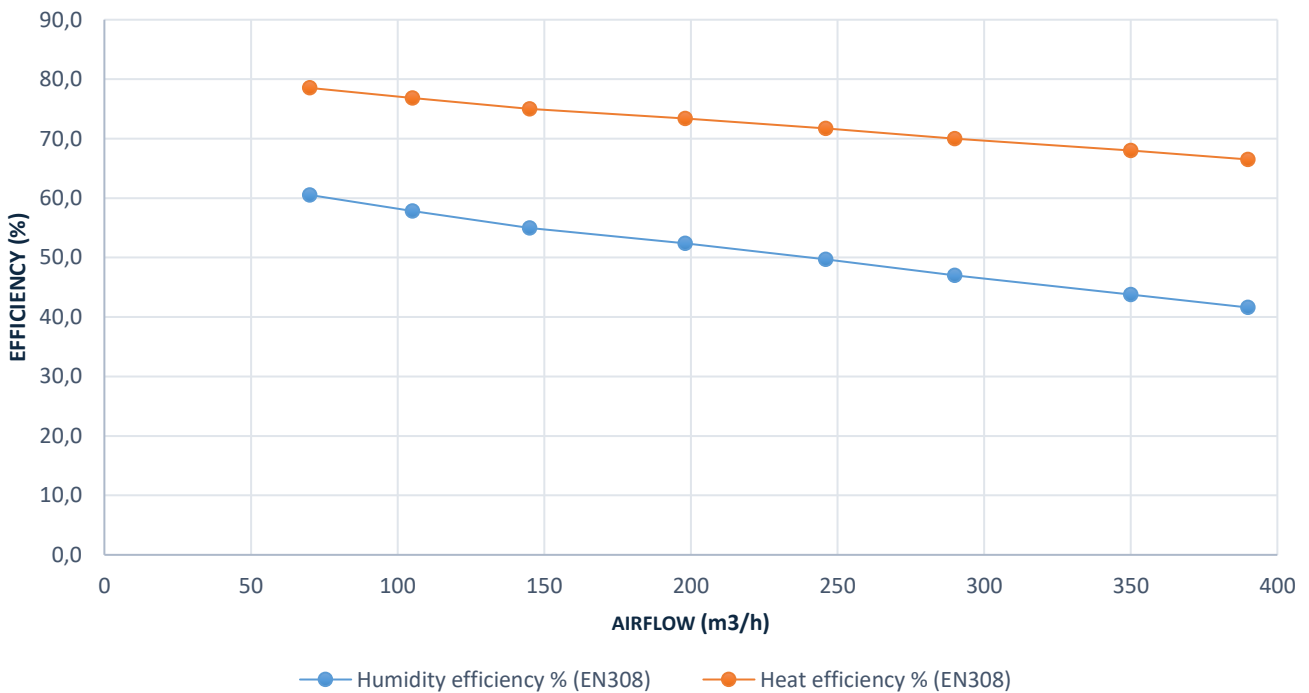

Chart 8

EFFICIENCY DIAGRAM - ERV - XF2-035-ECS0ERxxx-1A0
nominal airflow 350m³/h



2.3.6. Heat and Moisture Recovery Efficiency - XF2-045

- XF2-045 - Nominal flow rate 400 m³/h - (output 1)

Tab. 13

Commercial name		XFLAT-450 (nominal 400m ³ /h)								
Unit type		XF2-045-ECS0HRXXX-1A0				XF2-045-ECS0ERXXX-1A0				
Nominal output		400m ³ /h				400m ³ /h				
Type of recuperator		HRV - temperature				ERV - temperature/humidity				
		Flow rate (m ³ /h)	Temperature % efficiency (EN308)	Current (A)	Power supply (W)	Flow rate (m ³ /h)	Temperature % efficiency (EN308)	Humidity efficiency % (EN308)	Current (A)	Power supply (W)
Airflow level	1	110	91,2	0,18	16	110	77,5	59,1	0,18	16
	2	143	90,4	0,25	25	143	75,3	55,5	0,25	25
	3	183	89,9	0,39	44	183	73,9	53,3	0,39	44
	4	228	89,3	0,55	70	228	72,3	50,7	0,55	70
	5	284	88,6	0,82	110	284	70,3	47,5	0,82	110
	6	337	87,9	1,20	167	337	68,5	44,5	1,20	167
	7*	400	87,1	1,80	250	400	66,2	41	1,80	250
	Boost**	450	86,4	2,30	320	450	64,5	38,2	2,30	320
	ECODESIGN***	280	88,6	0,66	82	280	70,5	47,8	0,66	82

* Nominal airflow at an external pressure drop of 200 Pa

** BOOST mode – intensive ventilation for a set period of time

*** 70% of nominal airflow / 50 Pa

Chart 9

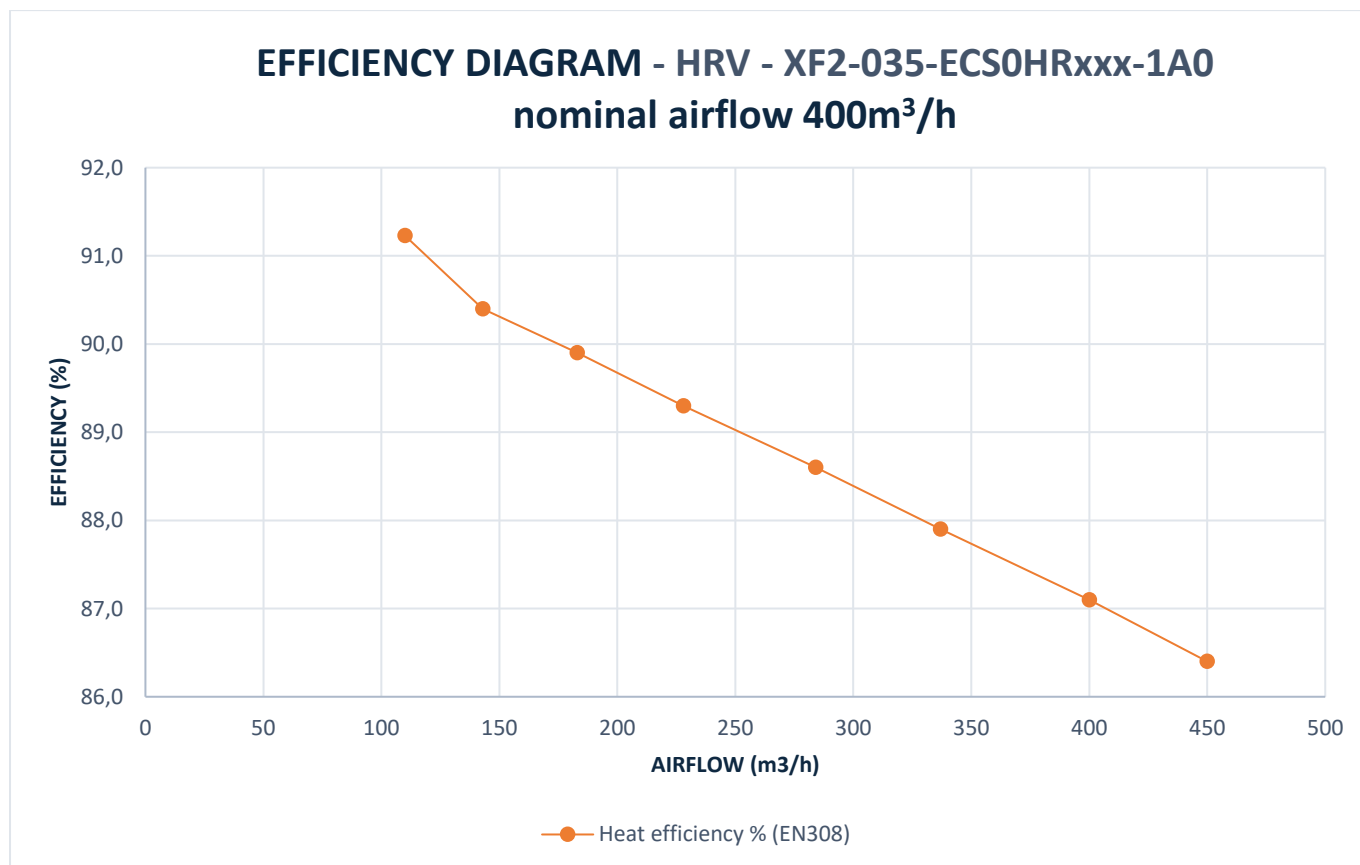

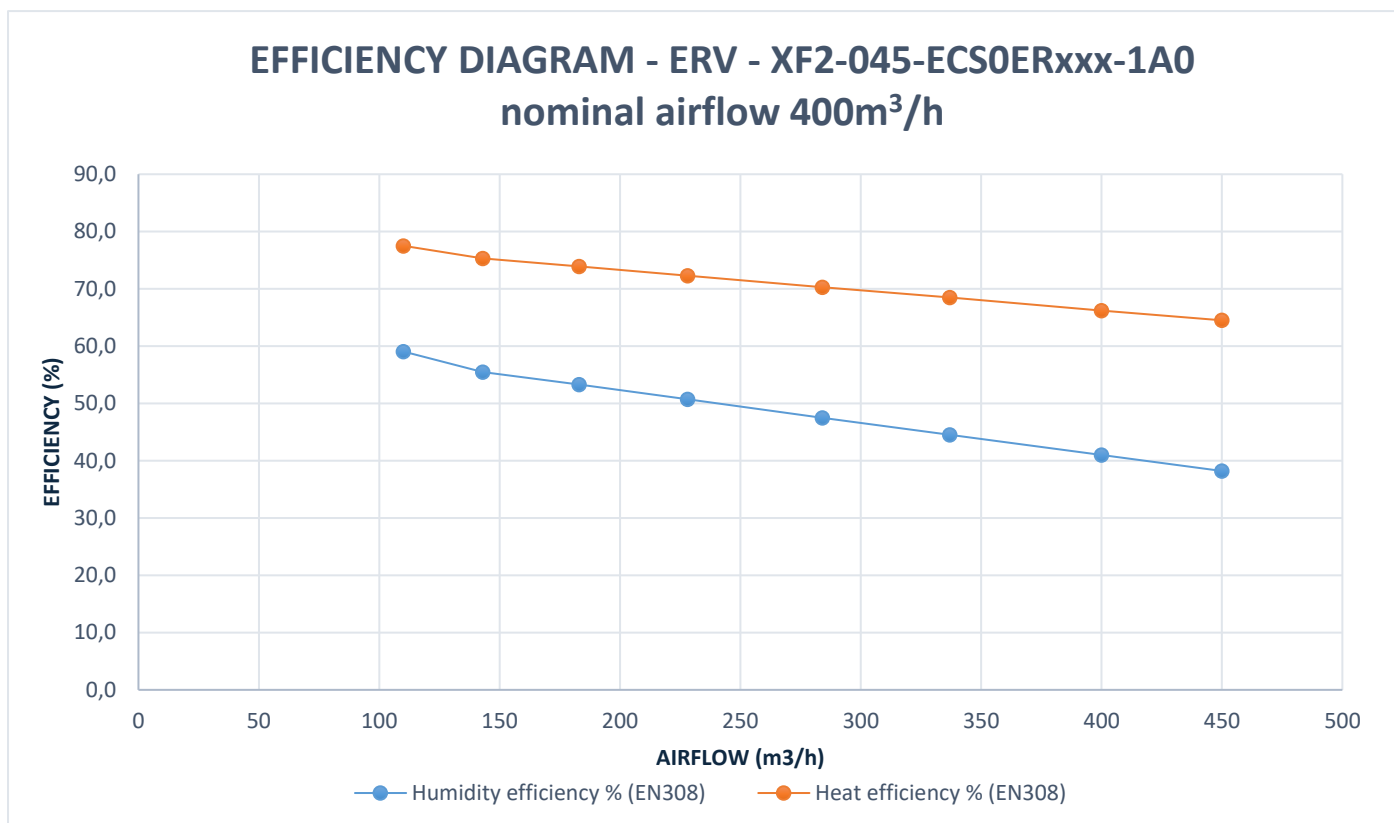

- XF2-045 - Nominal flow rate 450 m³/h - (output 2)

Table 14

Commercial name		XFLAT-450 (nominal 450m ³ /h)								
		XF2-045-ECS0HRXXX-1A0				XF2-045-ECS0ERXXX-1A0				
Unit type		450m ³ /h				450m ³ /h				
Nominal output		HRV - temperature				ERV - temperature/humidity				
Type of recuperator		Flow rate (m ³ /h)	Temperature % efficiency (EN308)	Current (A)	Power supply (W)	Flow rate (m ³ /h)	Temperature % efficiency (EN308)	Humidity efficiency % (EN308)	Current (A)	Power supply (W)
Airflow level	1	110	91,2	0,18	16	110	77,5	59,1	0,18	16
	2	152	90,3	0,28	28	152	75	55	0,28	28
	3	200	89,7	0,45	51	200	73,3	52,3	0,45	51
	4	256	88,9	0,67	101	256	71,3	49,1	0,67	101
	5	319	88,1	1,10	150	319	69,1	45,6	1,10	150
	6	387	87,2	1,70	240	387	66,7	41,7	1,70	240
	7*	450	86,4	2,30	320	450	64,5	38,2	2,30	320
	Boost**	450	86,4	2,30	320	450	64,5	38,2	2,30	320
ECODESIGN***	314	85,7	0,88	112	314	70	45,8	0,88	112	

* Nominal airflow at an external pressure drop of 200 Pa

** BOOST mode – intensive ventilation for a set period of time

*** 70% of nominal airflow / 50 Pa

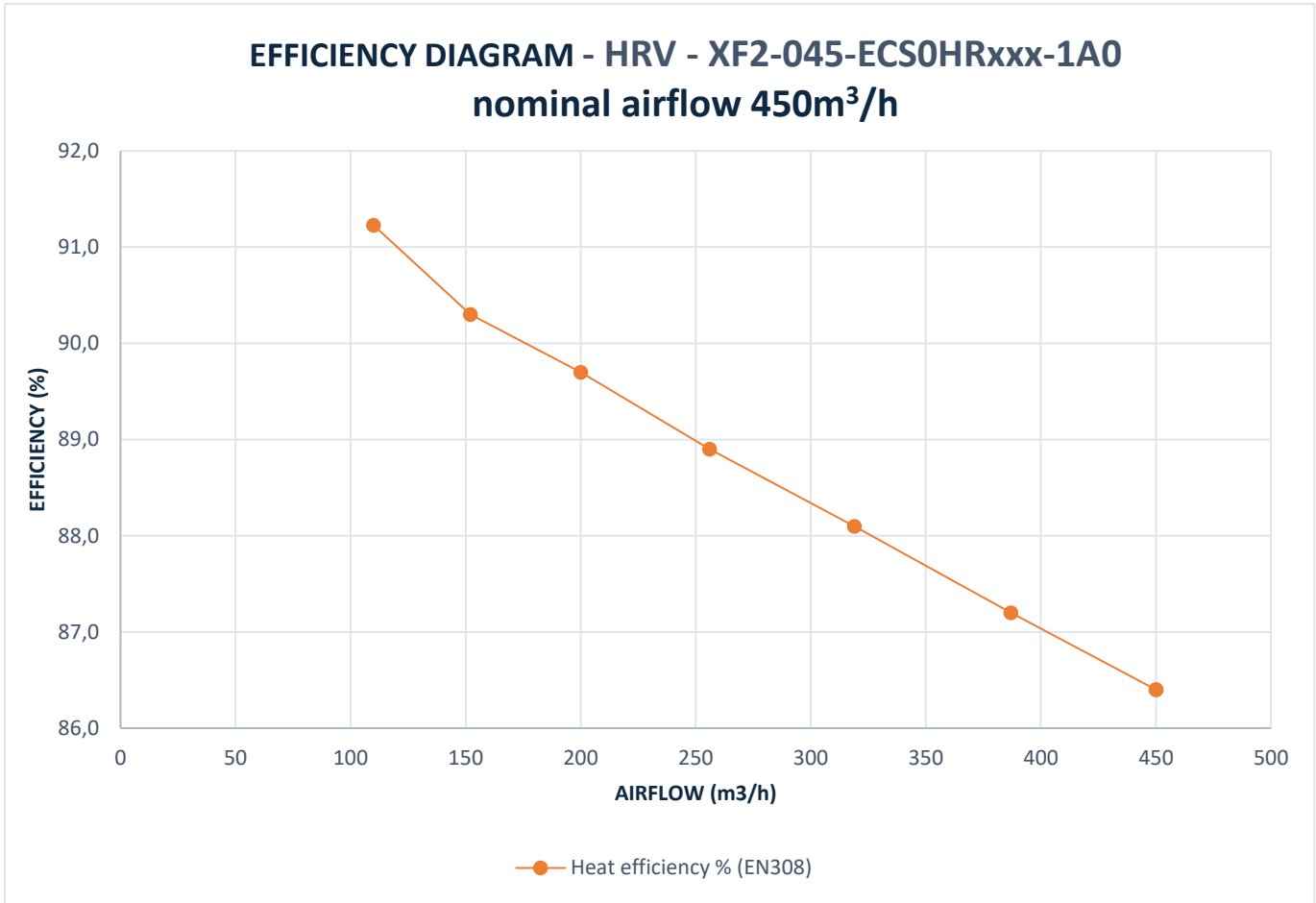
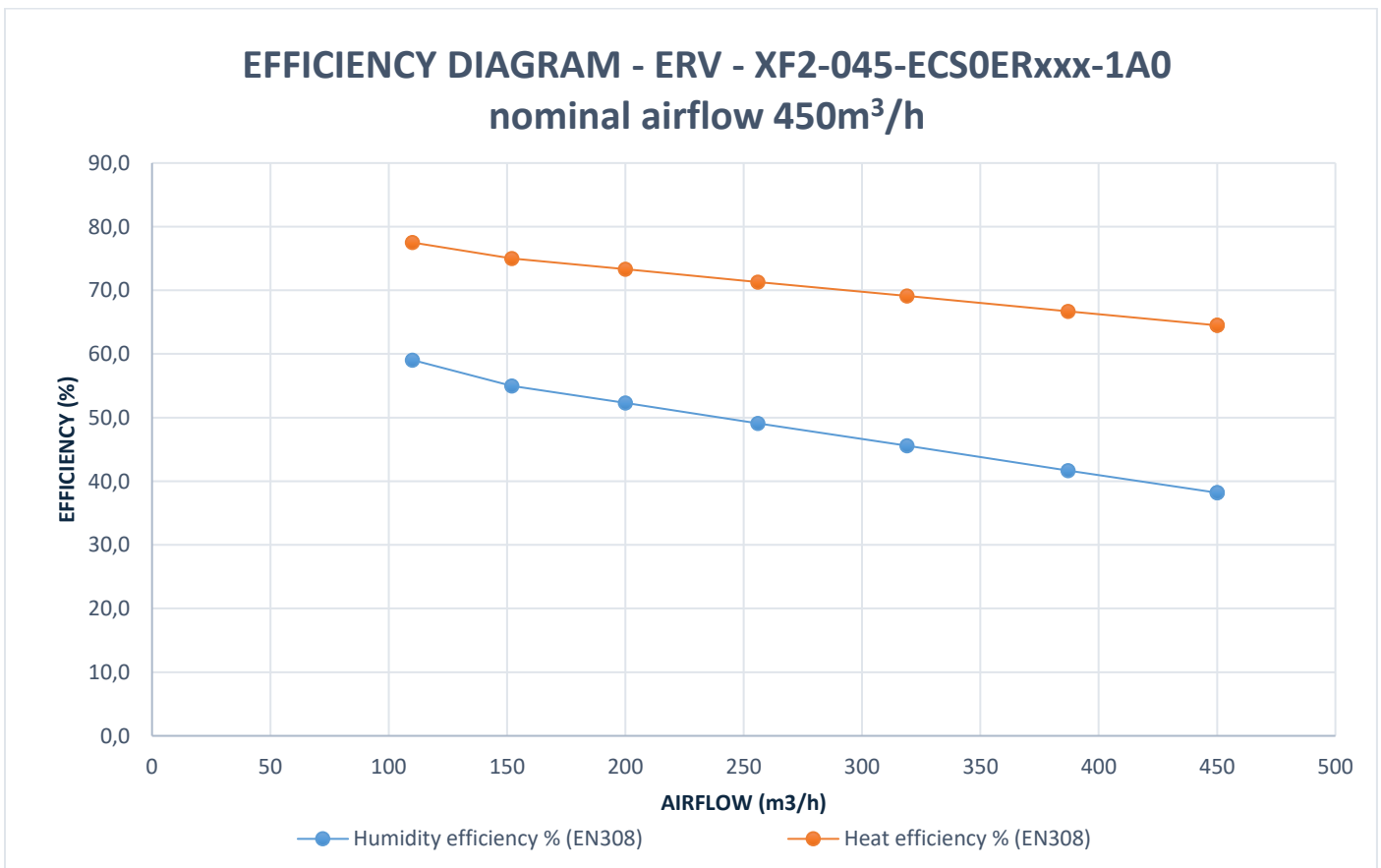

Chart 12



3. Installing the Unit

3.1. General information, recommendations and safety when installing the Xflat unit – XF2

3.1.1. Electrical Safety Before Unit Installation



- Before beginning any installation work, make sure that the wiring box or mains power socket that you want to use to connect the unit is equipped with a protective (greenish-yellow) wire or contact (pin).
- If you use a wiring box to connect the unit, you must turn off the power supply and ensure the power supply against accidental start.



Verify that the electrical connection point (wiring box, socket) meets the power requirements of the unit (voltage, current, etc.) listed on the rating plate of the unit. The electrical quantities required for the operation of the unit can be found in Chapter 3.6.3. Display of electrical parameters

3.1.2. Unpacking the Xflat Unit - XF2

- Always unpack the unit in a large enough space to allow the unit to be manipulated after unpacking.
- We never unpack the unit from the package at once, the unpacking of the unit is gradual, as stated in this manual according to the installation work in progress (protection of the unit from damage and dust generated during construction)

1

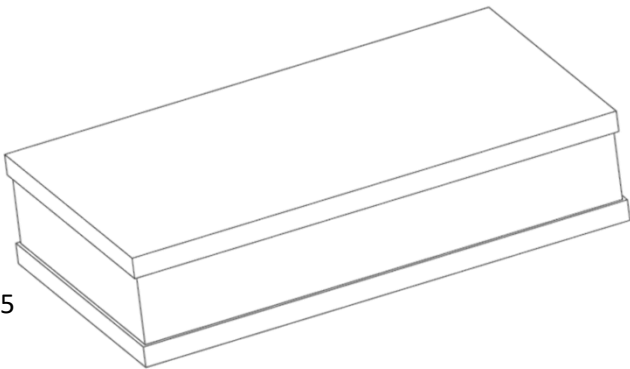

Pic.5

2

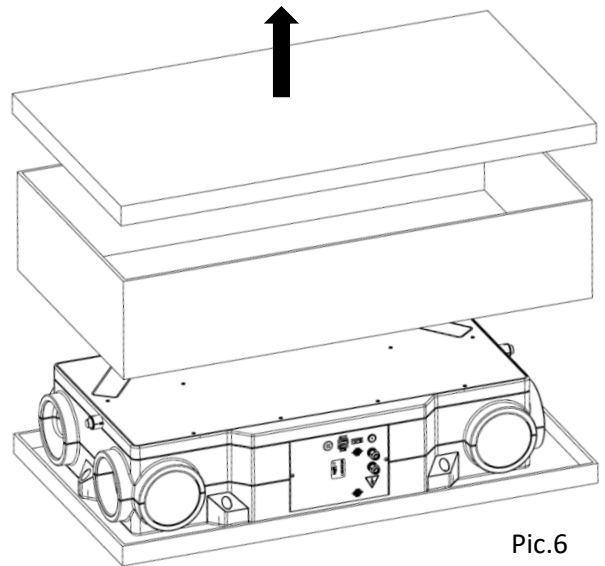

Pic.6

3

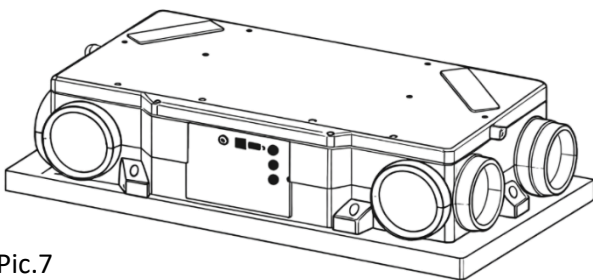

Pic.7

- Do not dispose of the bottom of the box, there is a drilling template at the bottom for easier installation of the unit.

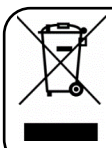

Please hand over all unnecessary packaging to the appropriate recycling points, where they will dispose of it professionally. Only packaging recycled in this way can be properly reused.



3.1.3. Unit Location



- When choosing a position for installing the unit, always consider the layout options of the building within the entire ventilation system (e.g.: location of dampers, supply and exhaust ducts, etc.). Consult the correct design of the entire ventilation system with a designer in the field of ventilation or a person knowledgeable in this field. The manufacturer is in no way responsible for the design of the air handling system.

- The unit must be installed in indoor and dry areas with a room temperature of +5 °C to +30 °C and with a maximum relative humidity of 70% non-condensing.



Consider placing the unit indoors away from surrounding objects with respect to the recommended distances from the unit (e.g.: replacing filters, opening the unit for service) which are given in Chapter 3.1.4.

- Check your options for connecting the condensate outlet to the drain.

3.1.3.1. Location and operation of the unit in the area with a fireplaces

- In the case of placing air ducts in areas with a fireplace, you can set up the disbalance of fans in the customer menu of the touch capacitive controller (must be ordered as an accessory – not included) or in the service application (accessible only to authorized service technicians) (more air is supplied than discharged). Fan disbalance cannot replace a separate air supply to the fireplace in any way due to the possibility of control according to AQS sensors.
- For the proper functioning of the fireplace with the unit, consult the location with a chimney sweeper. Otherwise, the unit may result in malfunction.

3.1.3.2. Location and operation of the unit in the air conditioning unit area

- When operating the unit in the summer months and using air conditioning in a ventilated area, condensate may form inside the unit in the opposite supply branch.
- For trouble-free operation, we recommend installing a unit equipped with an enthalpy heat exchanger (XF2-035-ECS0ERxxx-1A0, XF2-045-ECS0ERxxx-1A0).

3.1.4. Minimum installation distances

- General distances from solid objects:

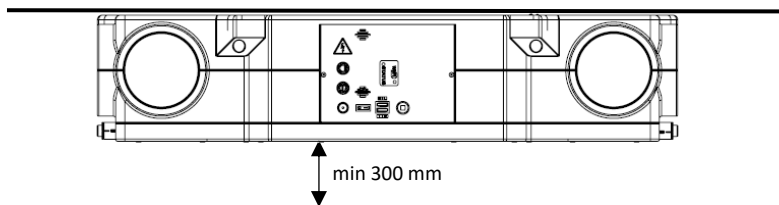

Pic.8

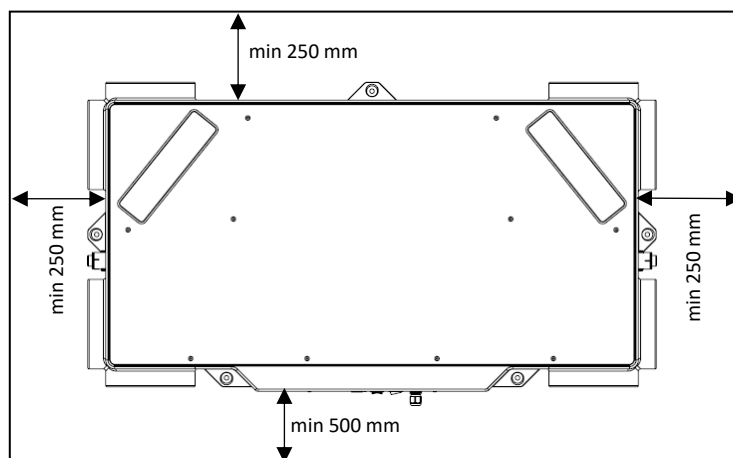

Pic.9

- The unit must be installed and adjusted (right/left layout) in such a way that the airflow direction through the unit itself is identical to the airflow in the air handling system.
- Failure to observe the specified distances may not operate properly and may damage the fan, increase the noise level, or prevent service access to the unit.

3.1.5. Allowed installation positions of the XF2 according to the selected right/left configuration of the unit



Switching the unit to the right/left version is given in a separate chapter 4.2.1.

3.1.5.1. Spigot Orientation - Right Unit Version - Factory Setting

UNDER-CEILING INSTALLATION – LID AT THE BOTTOM

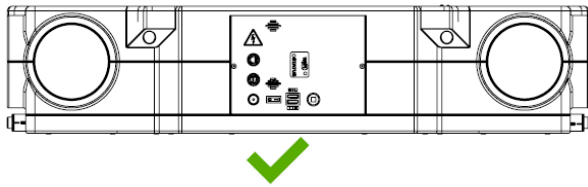

ON THE WALL VERTICALLY

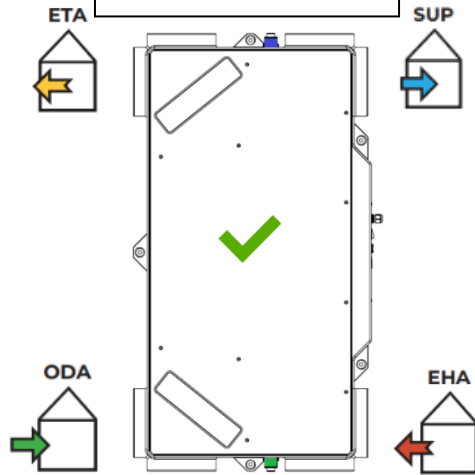

Pic. 10

Pic. 11

3.1.5.2. Spigot orientation - left version of the unit

ON THE WALL VERTICALLY

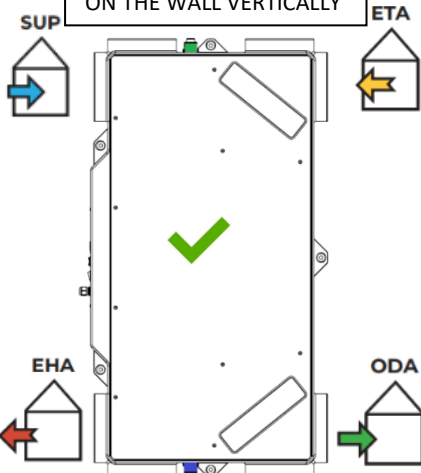

Pic. 12

UNDER-CEILING INSTALLATION – LID AT THE BOTTOM

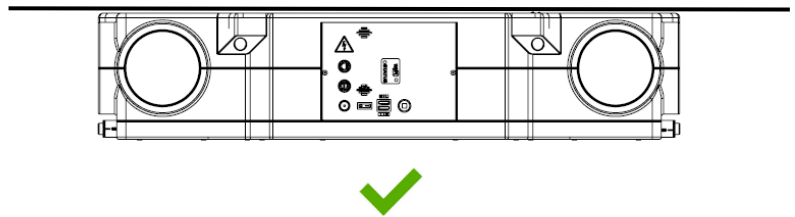

Pic. 13



- Placement in any other position is prohibited
- Access to the unit must always be maintained from the front (lid side) for access to the filters and for possible servicing. If the unit is placed under a wall, the ceiling must be a wall, the false-ceiling must be equipped with an inspection opening for access to the unit with the possibility of removing the lid.

3.1.6. Prohibited Xflat 350/450 Installation Positions

CEILING INSTALLATION – LID AT THE TOP

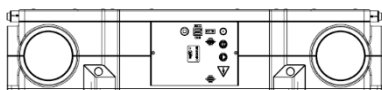

ON THE WALL VERTICALLY – FILTERS ON THE LEFT

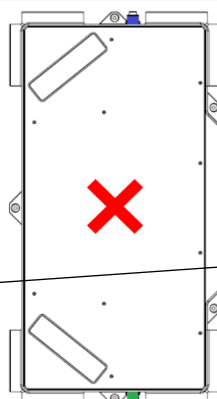

ON THE WALL VERTICALLY – FILTERS ON THE RIGHT

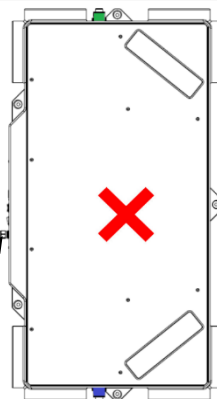

ON THE WALL HORIZONTALLY

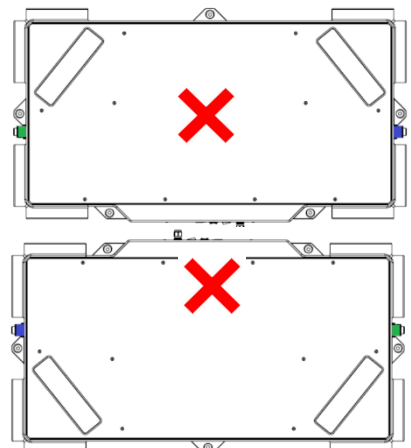

Pic. 14

Control orientation

3.2. Installing the Xflat Unit - XF2

- The unit must be operated in closed and dry locations with a room temperature ranging from +5°C to +30°C.
- The heat recovery unit must be installed in accordance with the general and local safety regulations.
- The heat recovery unit may be installed, connected, commissioned and repaired by a person with appropriate education, experience and knowledge of the relevant regulations, standards as well as possible risks and possible hazards, or by an appropriately trained service technician.
- **Failure to follow the installation procedure may result in damage to the unit, malfunction, or even possible damage to the user's health and property.**
- **Be extra careful when carrying out the drainage of condensate using a condensation siphon (siphon included) into the sewer pipe. The manufacturer of the unit accepts no responsibility for damage caused by the incorrect installation of the condensation drain, drain pipes and other peripherals necessary for their operation.**



3.2.1. Mounting Hardware Required to Install Xflat XF2 - General Requirements

- To install the unit, prepare the auxiliary mounting hardware (not included):
 - o Anchoring elements (e.g.: dowels, dowel screws) 5 pcs
- Choose the anchoring material according to the wall or ceiling design, the weight of the unit and the weight of the connected peripherals.



The weights of the unit variants are given in point 2.3.1. "Basic technical parameters"
 The dimensions of the unit are specified in point 2.2. "Main dimensions of the Xflat XF2-035 unit; XF2-045"

3.2.2. Installing the unit on a wall or ceiling

- Choose a suitable anchoring material (not included) based on the composition of the wall, ceiling. To use the suspension system of the unit, choose a screw with max. $\varnothing 6\text{mm}$
- **The wall or ceiling to which you will anchor the unit must always be strong and cohesive enough. If necessary, contact an expert in the field – structural engineers.**
- Use a spirit level to measure the anchor holes for fixation of the unit. For easier measurement of mounting holes, use the mounting template located on the bottom of the box. Alternatively, place the unit on a wall or ceiling and use a spirit level to level it.
- **Under no circumstances should the unit tilted**
- Find the mounting holes for anchoring the unit.

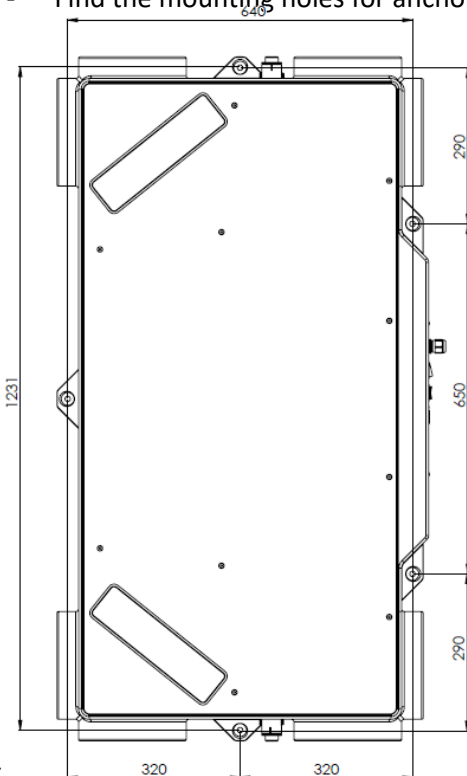

Pic.15

Version 001 – GBR (01.03.2026)

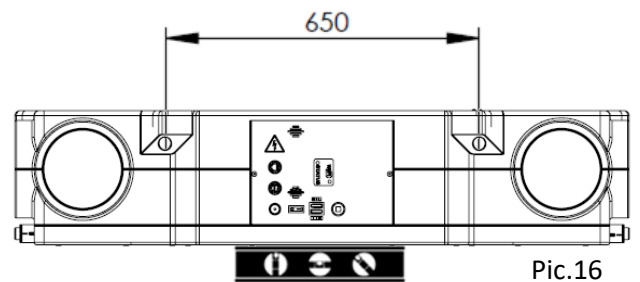

Pic.16

Installation template - bottom of the box

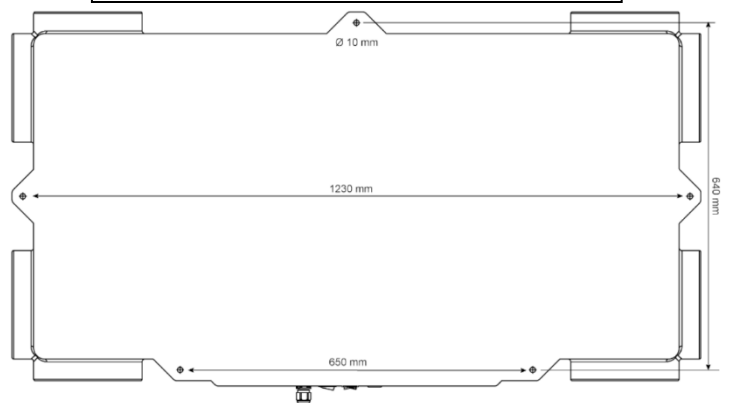

Pic.17
D-502-0707

- Drill holes for anchoring, fit with suitable anchoring material (dowels). Use the mounting feet (5x) located around the perimeter to attach the unit. The mounting feet are equipped with spacers to better define the contact force during installation – DO NOT REMOVE THE SPACERS FROM THE UNIT, there is a risk of damage to the mounting feet and the body of the unit.



- **Tighten the anchor bolts appropriately so that the unit is secured against arbitrary movement – falling.**
- Make sure to properly align the unit LEVEL with a spirit level, NEVER TILT THE UNIT in any direction.

3.2.3. Condensate drain connection – siphon

- The unit must always be equipped with a siphon (included) with a connection to the sewage system.
- Before the first start-up or after the unit is shut down (the unit is switched off for a long time), the siphon irrigation and condensate drainage clearance must always be checked after re-start.
- The unit is equipped with a condensate drain for each version:
 - o Right version – 1x outlet for both permitted positions – green marked condensate outlet
 - o Left version – 1x outlet for both permitted positions – blue marked condensate outlet
- Condensate wiring diagram located on the unit with the orientation of the sockets



Pic.18

3.2.3.1. Condensate drains right version of the unit

- rocker switch on the body of the unit in position "R" or set in the service app (by authorized technician) – factory settings

Vertical on the wall –
condensate outlet colour

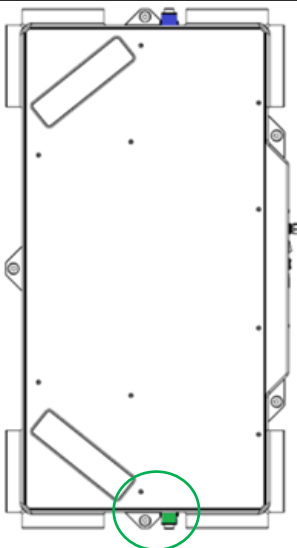

Ceiling – condensate outlet nut colour GREEN

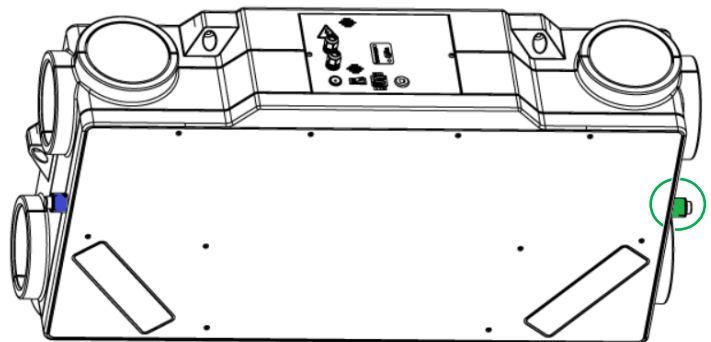

Pic. 20

Pic. 19

3.2.3.2. Condensate drain left version of the unit

- rocker switch on the body of the unit in the "L" position or set in the service app (authorized technician)

Vertical on the wall –
condensate outlet colour BLUE

Ceiling – condensate outlet colour BLUE

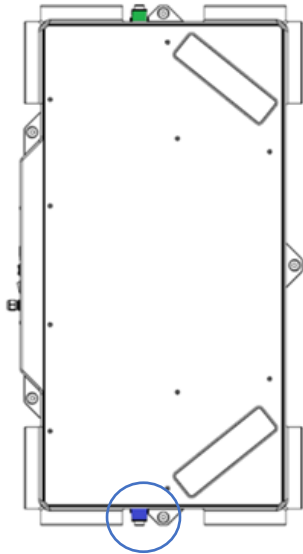

Pic. 21

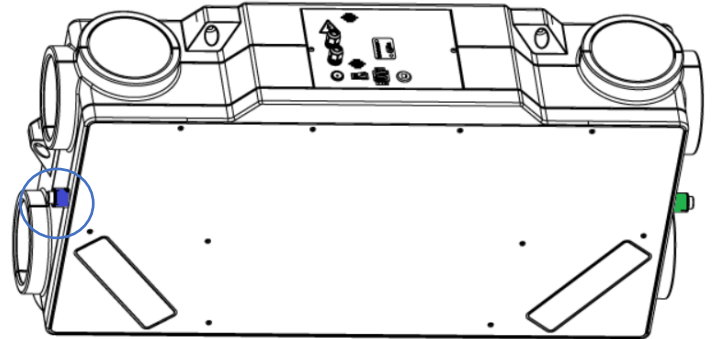

Pic. 22



- **The siphon must always be watered, well connected and sealed to the outlet of the unit, otherwise there is a risk of condensate not draining from the unit and thus accumulation of condensate in the unit with subsequent possible overflow of the condensate tank. This can subsequently lead to property damage.**



3.2.3.3. Connection of the condensate drain to the siphon

Depending on the installation position and the version of the unit, select the appropriate condensate outlet. Correctly determine the condensate outlet according to clauses 3.2.3.1., 3.2.3.2.

- Cut off the end of the condensate outlet in a length of 5mm

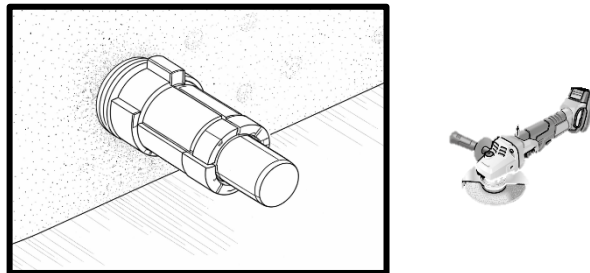

Pic. 23

- Remove the PVC siphon hose $\varnothing 33/25$ – 1m and 2pcs of the 2.5x120mm cable tie from the unit package
- Approximately halfway through the length of the siphon hose, make a loop with a diameter of 150mm.
- Secure the loop with 1 piece of tie-up strap, against arbitrary movement, but at the same time in such a way as not to deform (break) the siphon hose

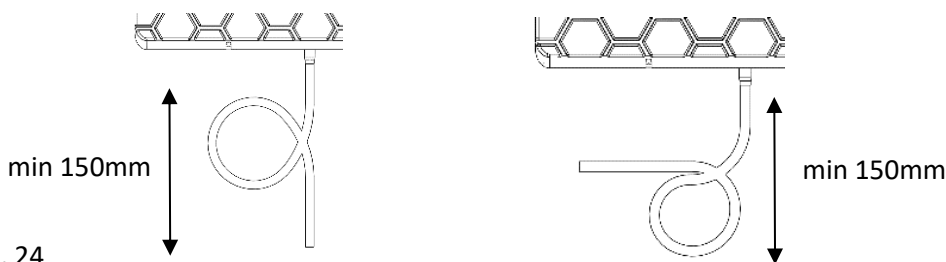

Pic. 24

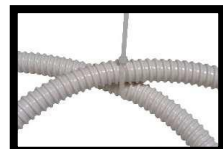

- **Pay close attention to maintaining the loop diameter of 150mm and using appropriate force when tightening the tie strap. If these conditions are not met, there is a risk that condensate will not drain out**

of the unit and thus condensate will accumulate in the unit with subsequent possible overflow of the condensate tank. This can subsequently lead to damage to property and the user's health.

- Water the siphon – pour water into the siphon from the connection side to the unit's drain until the water flows out through the other side of the siphon.
- Place the siphon on the main drain
- Orient the created siphon loop so that it acts as a water seal.

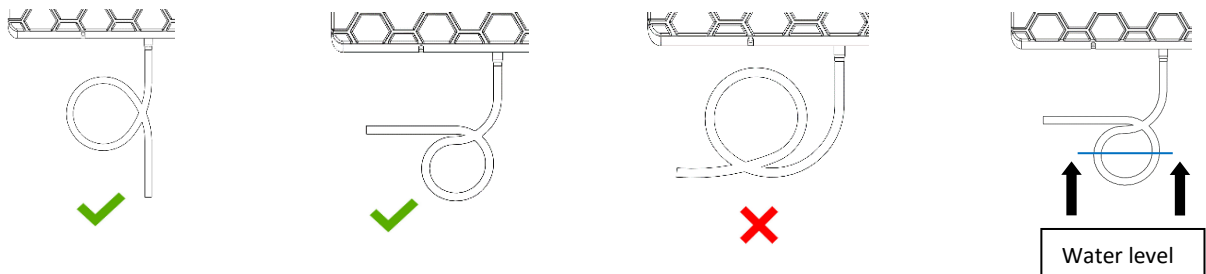

Pic. 25



- **When creating a bend – elbow on the siphon hose, pay attention to the correct bending radius of the hose to prevent it from "breaking" and thus strangling the hose and preventing the condensate from draining.**
- Secure the created siphon with a second 2.5x120mm cable tie (included) to the main drain located on the unit.

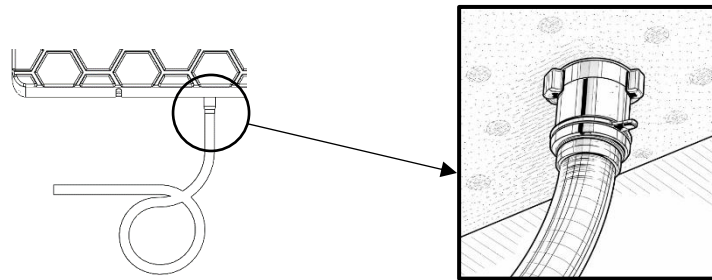

Pic. 26

- Adjust the other end of the siphon hose lengthwise and connect it to the sewer system while maintaining the minimum height of the difference between the siphon hose and the sewer connection.

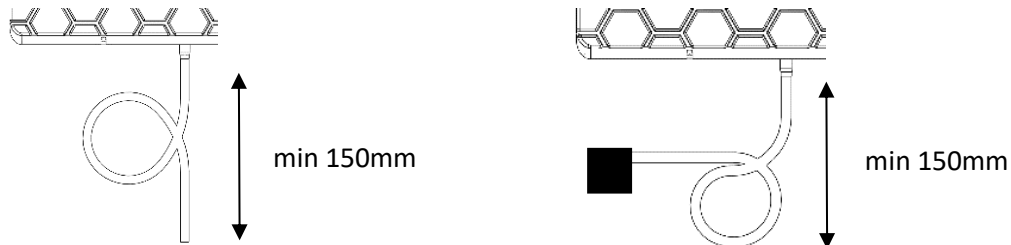

Pic. 27



- **Extension of the siphon hose is permissible only in the place behind the created hose loop. Extend the extension with a hose of the same or larger diameter using a hose connector. Always make sure that the inner diameter is reduced as little as possible with the hose connector.**

3.2.4. Connecting the air duct to the unit

- To connect the air duct to the unit, use the spigots located at the corners of the unit.
- To connect the duct, you can use both the inner diameter of the outlet of 160mm and the outer diameter of the outlet of 200mm.

3.2.4.1. General conditions for connecting ventilation ducts

- Sockets located in the corners of the unit allow ducts to be connected both in the axis of the unit (factory setting) and perpendicular to the unit.
 - o The use of a outlet perpendicular to the unit (to the side) significantly reduces the needed space at the installation site
 - o Opening any outlet in the corner of the unit depends on the selected unit type:
 - Unit without preheater (XF2-xxx-xxxxxxXxW-1A0) - any outlet can be opened, regardless of the number of sockets in the axis and the sockets rotated perpendicular to the unit.

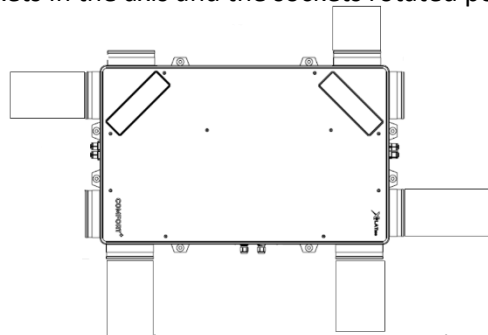

Pic. 28

- Unit with integrated preheater (XF2-xxx-xxxxxxPxW-1A0) – the outlet in which the integrated preheater is located must remain in the factory configuration – **MUST NOT BE MODIFIED IN ANY WAY, RELOCATED.**

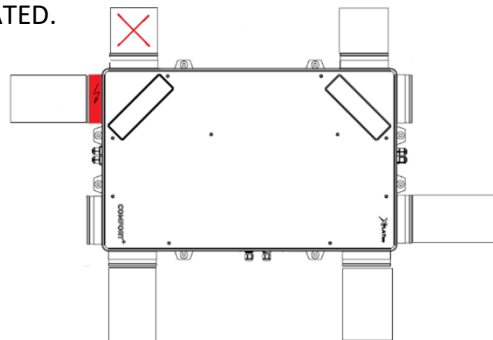

Pic. 29



Any manipulation of the outlet in which the integrated preheater is located and the side blind outlet is strictly prohibited – it must remain blinded. Otherwise, there is a risk of irreversible damage to the unit with possible damage to property and health.

3.2.4.2. Removing the Plug from the outlet

- Each outlet plug is secured against spontaneous falling out by a screw to the body of the unit. Remove the plug before placing the duct on the through-hole. To remove the plug, proceed as follows:

<p>1. Unscrew the self-tapping screw (TORX 25) from the blind outlet</p>	<p>2. Use the free outlet to push the plug out of the outlet</p>	<p>3. You can also use the removed plug to blind the outlet in the opposite way</p>

Pic. 30

- The use of outlets perpendicular to the unit has no effect on the flow rate or on the reduction of external pressure loss

3.2.4.3. Duct installation and insulation

- To slide the duct, proceed as follows:
 - o Slide the duct over the entire outlet
 - o Seal the joints with aluminum tape or connecting sleeves to prevent vibration transmission.
 - o Then insulate connected ducts with thermal insulation material (stone wool, butyl rubber, etc...)
 - o Pull the duct insulation over the entire outlet to the unit and secure against arbitrary movement.
 - o This prevents the formation of a thermal bridge at the connection point.

Pic. 31

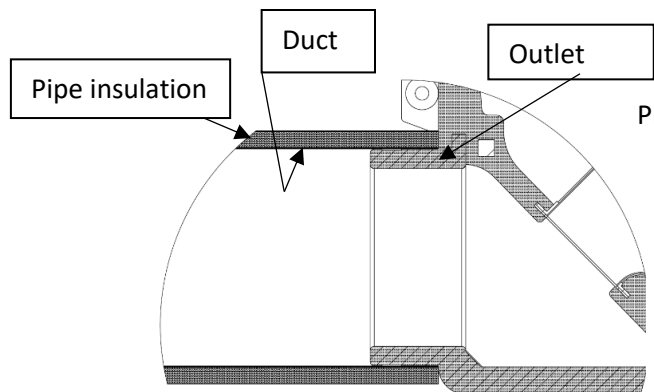
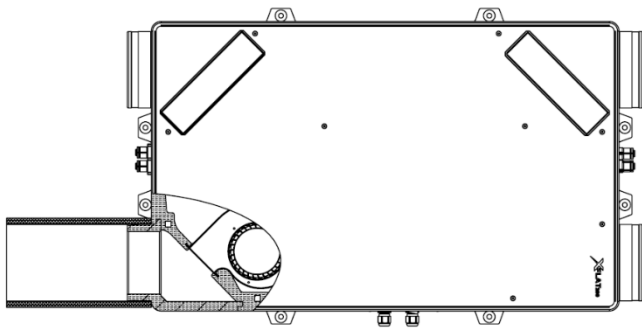

Pic. 32

- All duct joints that are connected to the unit must be sufficiently sealed to prevent unwanted leaks and thus subsequent problems, e.g.: condensation.

3.3. Wiring – connection to the mains

3.3.1. General information - safety



- Before beginning any installation work, make sure that the wiring box or mains power outlet you want to use to connect the unit is equipped with a protective (greenish-yellow) wire or contact (pin).
- If you use a mains plug to connect the unit, it must remain accessible at all times so that the unit can be safely disconnected from the mains in the event of an emergency.



- Verify that the power supply meets the power requirements of the unit (voltage, current, frequency, etc.) listed on the rating plate of the unit. Chapter 3.3.3. Display of electrical parameters.
- The relevant circuit must be protected by a maximum of 16 A in the electrical power distribution.
- The electrical cable for connection to the mains must not be broken.
- Local electrical codes must always be respected.
- The electrical connection of the unit to the mains may only be carried out by persons qualified for this activity with a valid authorization and knowledge of the relevant standards and directives in the given country.
- Before starting any assembly work, it is necessary to turn off the power supply. The switch must be secured for the duration of the installation before being switched on again by an unauthorized person. The switch must be with a minimum contact distance of 3 mm.
- A two-pole disconnect device (circuit breaker) must be connected to the supply power supply of the unit.
- It is forbidden to interfere with the internal wiring of the unit in any way, unauthorized interference with the unit may result in the loss of warranty service entitlements
- This unit belongs to the product group with a type Y connection. If the power supply is damaged, it must be replaced by the manufacturer, its service center or a similarly qualified person in order to avoid a hazardous situation.
- The unit is classified as a protection class 1 appliance in terms of protection against electric shock.
- The supply voltage to the 1~230V/50-60Hz unit must not be modified in any way, otherwise there is a risk of damage to the electrical elements of the unit.

3.3.2. Connecting to the mains

- The unit is equipped with a separate Licna (cable) power cable. The shaving of cables to individual wires is 50 mm. The individual wires are equipped with press-fit terminals.
- The length of the power cord of approx. 1 m can be shortened by a qualified person as required.
- Individual wires are color-coded
 - o Brown/Black – Phase Conductor – L
 - o Blue – Neutral Wire – N
 - o green-yellow – Protective conductor – PE

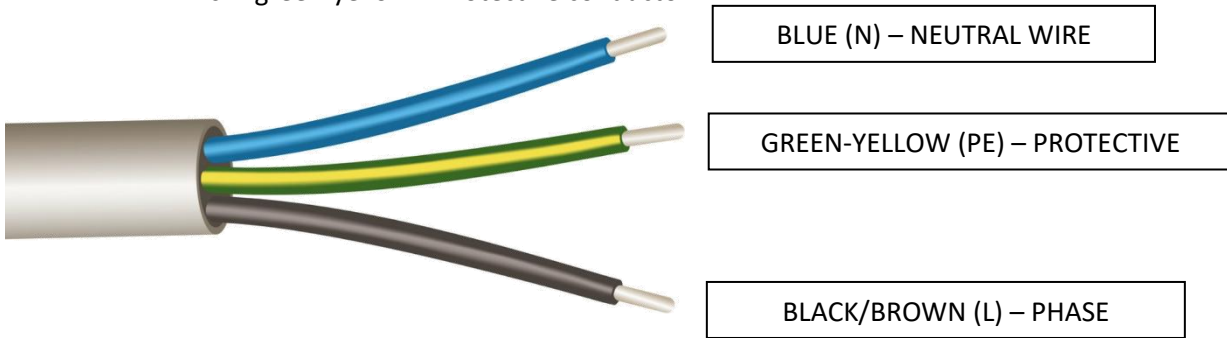

Pic. 33

3.3.2.1. Connecting the unit to the wiring box

- The power cable is prepared by the manufacturer for connection to the wiring box.
- To connect the power cable to the mains, use appropriate connecting elements (e.g.: terminal block, spring terminals, etc...)
- **The installation of the power cable in the wiring box and the connection to the mains must be carried out by a qualified person who is legally authorized for this activity and has knowledge of the relevant standards and directives in the given country.**



3.3.2.2. Connecting the unit to an electrical outlet

- The power cord can be equipped with a plug with a protective conductor (pin) – not included.
- **Connection – the installation of the plug on the power cord must be carried out by a person qualified for this operation, who is authorized for this activity and has knowledge of the relevant standards and directives in the given country.**



3.3.2.3. Unit fuse recommendation XF2-035; XF2-045

- We recommend securing the unit with a 1-phase (1x230V) fuse element with current values.

Tab. 15

- **The correct value of the safety element must be designed by an electrical expert with regard to the conditions at the installation site, e.g. (cable length)**



Unit type		Circuit breaker	Number of phases × voltage
XF2-035 XF2-045	XF2-035-ECS0HRP×W-1A0	16 A	1 x 230 V
	XF2-045-ECS0HRP×W-1A0		
	XF2-035-ECS0HRX×W-1A0	6 A	
	XF2-045-ECS0HRX×W-1A0		

3.3.3. Display of electrical parameters

- All electric parameters of the unit are shown on the nameplate

Pic. 34

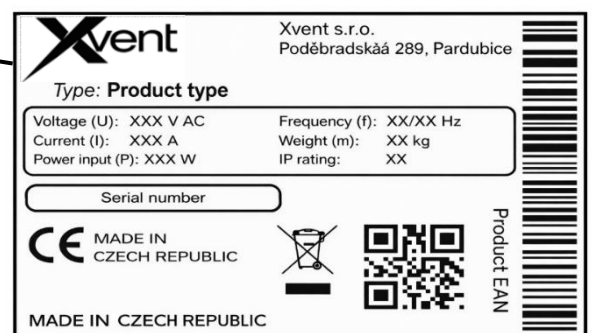
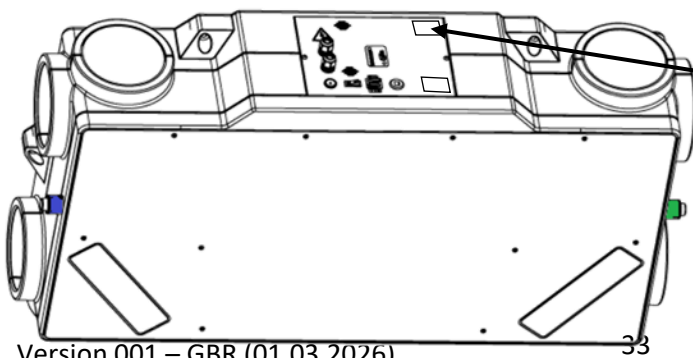

4. Controls

4.1. General information - safety



- For the proper operation of the unit (in manual mode), there is no need to connect anything else to it. The unit is ready for immediate use after installation.
- **For functional control of the unit, the availability of a WIFI network with the possibility of internet connection must be ensured in the installed area. The control of the unit is provided by a web application on the web domain "WIFI.module.eu". Without the ability to connect to the Internet, the unit cannot be controlled using the app**



- To operate in automatic mode, you must connect the CO2 or RH air quality sensor accessories.
- **Always switch off the unit with the main switch (position 15) before entering the control.**

4.2. Setting the unit with mechanical switches

4.2.1. Right/Left Unit Switching



- Unit control allows switching between right and left versions
- The orientation of the sockets for the right or left version of the unit is explained in a separate chapter 3.1.5.
- Setting the version is done by turning the switch (position 17) to the position:
 - o Position "R" – Right Version – Factory Setting
 - o position "L"– left version

Pic. 35

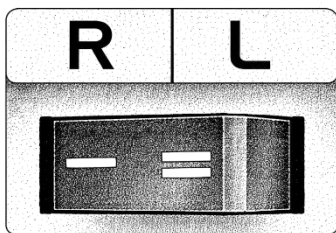
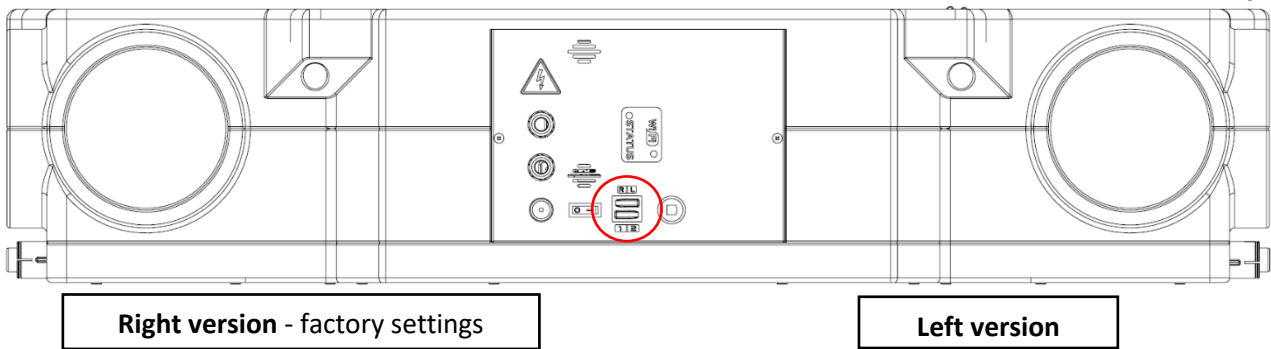

Pic. 36

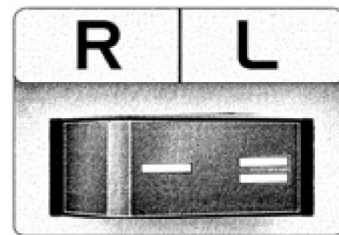

Pic. 37

4.2.2. Settings – switching the rated power of the unit

- On the unit, using a rocker switch (position 18), it is possible to switch the nominal air output:
 - o XF2-035:
 - Position 1 – nominal flow rate 300 m3/h
 - Position 2 – nominal flow rate 350 m3/h
 - o XF2-045:
 - Position 1 – nominal flow rate 400 m3/h
 - Position 2 – nominal flow rate 450 m3/h

Pic. 38

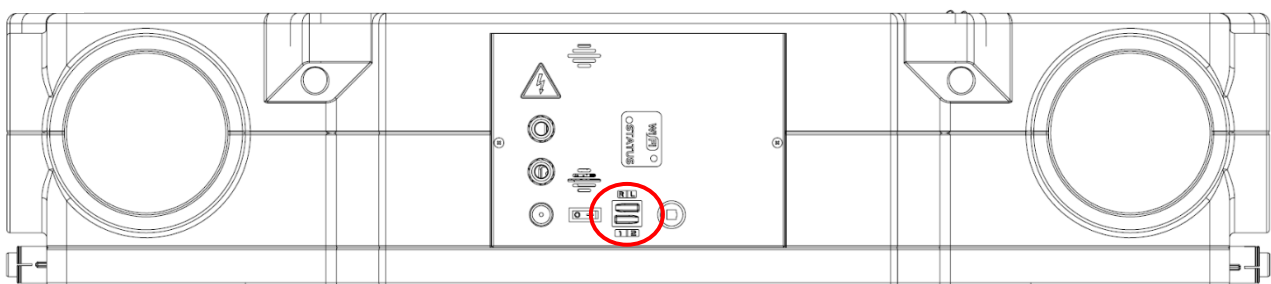

Position 1.

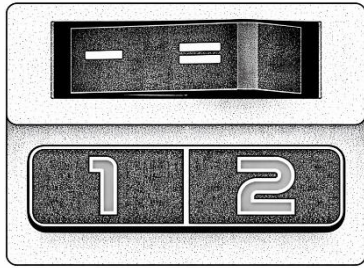

Pic. 39

Position 2 - factory settings

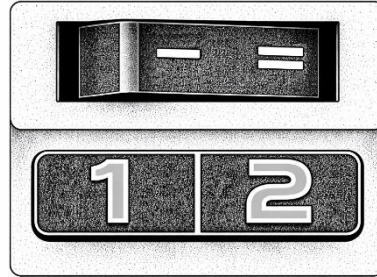

Pic. 40

4.3. Connecting accessories to the control

- The accessories listed below are not included in the delivery of the unit and must be ordered separately.

4.3.1. Access to control board

- Plug the unit settings and electrical accessories into the control box.
 - o Loosen the Ø3.5x20 flat head screw 2 times that secures the control box cover plate.
 - o Loosen the bushing nuts from the supply and communication cable
 - o Remove the control box cover plate
 - o Connect the necessary electrical accessories
 - o The control is equipped with two connector sizes, each connector PIN is marked with a number, which is also listed on the control motherboard.
 - o **The parity of the individual connector numbers with the markings on the control board must not be confused. Otherwise, there is a risk of damage to the unit**
 - o To connect the individual components, spring connectors with manual locking of the wire-to-wire type (must be equipped with a fixed terminal) and a solid wire in the range of permissible cross-sections and shaving are used:
 - Small connector 0.2 to 0.5 mm²
 - Large connector 0.2 to 2.5 mm²
 - o Before inserting the wire into the terminals, first press the locking orange button. Then insert the wire, release the lock and pull lightly from the terminal to verify that the wire is properly secured. When it is necessary to remove the wire from the terminal, the procedure is the same, but in reverse.



Pic. 41

a) Loosen the control housing locking screws

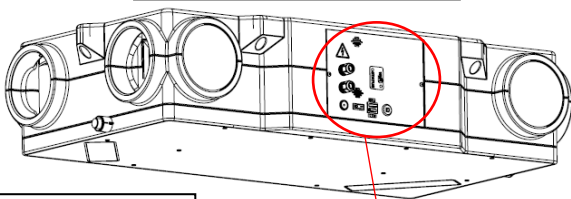

b) loosen the grommets and carefully remove the control cover

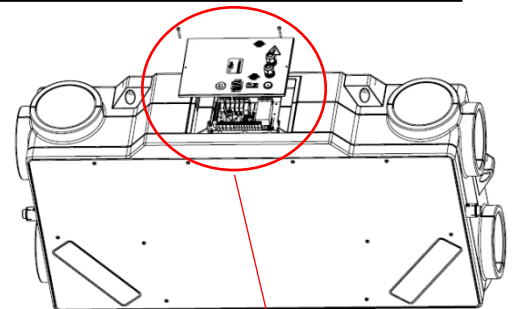

- Grommet for Modbus Cable
- Grommet for power cord
- Grommet for connecting accessories e.g.: air quality sensors, connection preheater, etc...

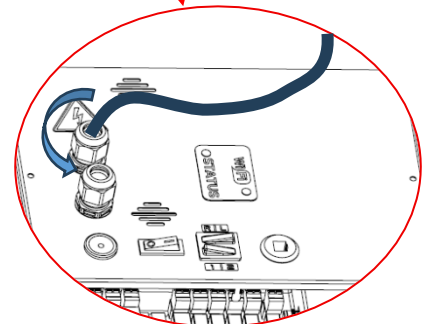
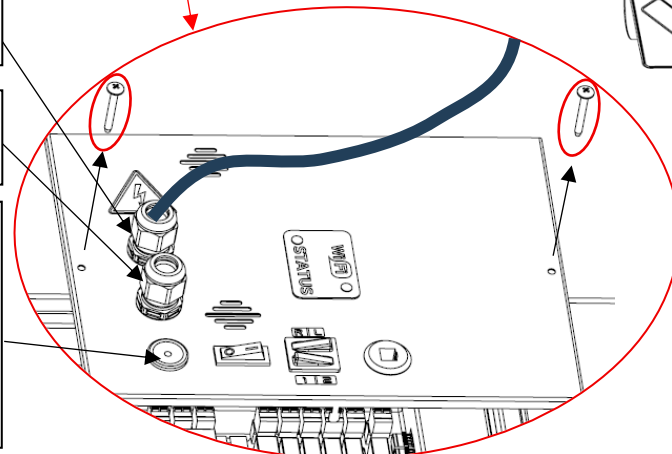

Pic. 42

- Use the membrane opening to connect accessories.



- The communication cable for connecting the unit to the superior Modbus system is connected directly to the control of the unit to the control board – terminals no. 30/31/32 – specified in separate chapter 4.3.2.3.



- **The optimal conductor cross-section must be selected according to the actual length of the conductor route, but the maximum conductor cross-section can be:**

- Small connector – 0.5 mm²
- Large connector - 2.5 mm²



- **All wires must be connected to the individual PINs of the connectors with reasonable force to prevent damage to them or damage the electrical board. For wires of the face type, there must be a pressed end (ferrule).**



- **The control is integrated into the body of the unit by default and must not be handled in any other way than specified in this manual.**

4.3.2. Connection of electrical accessories, signaling

- Location of terminals in the control of the unit for connecting electrical accessories + signaling Pic. 43

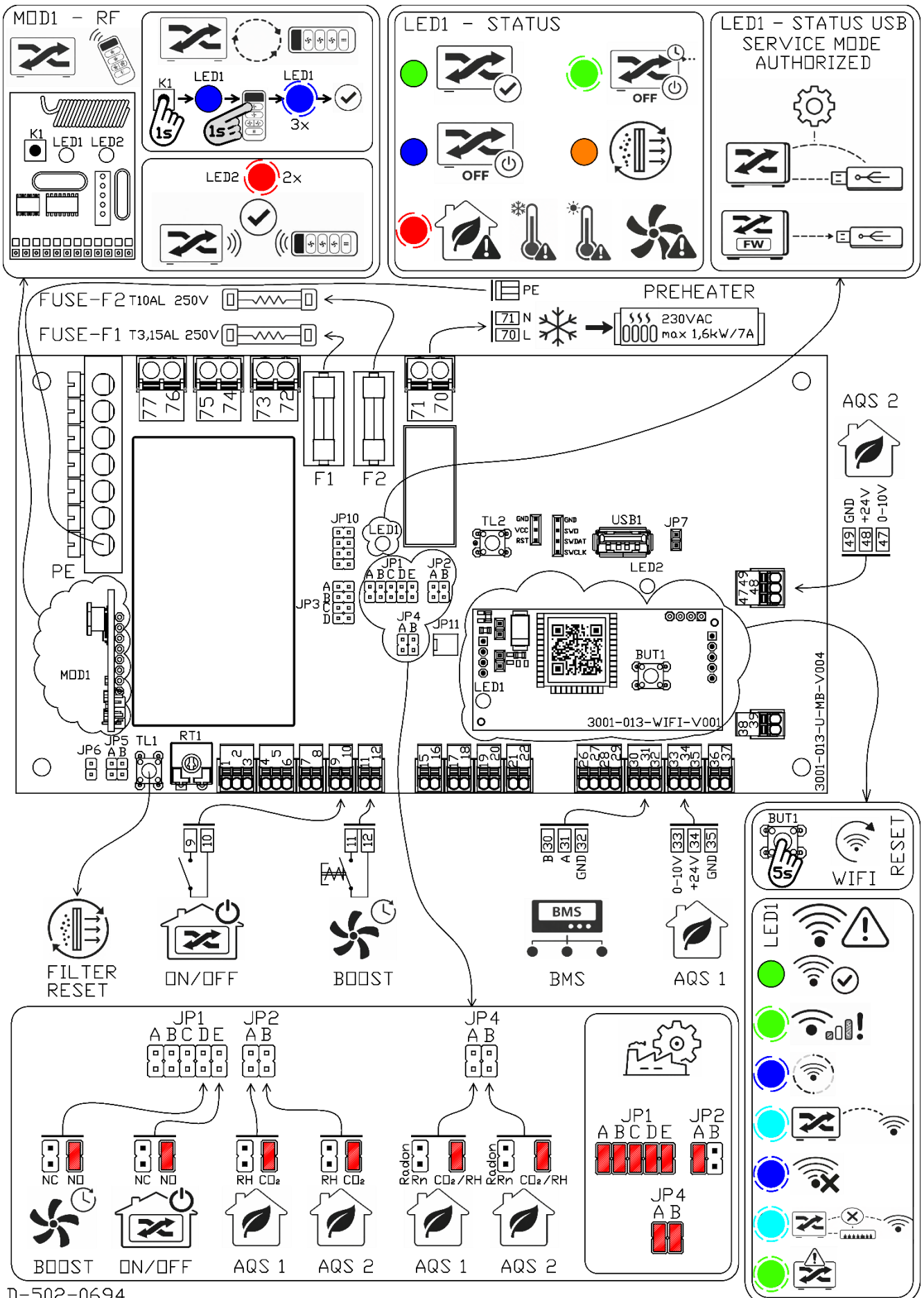

4.3.2.1. Wall Wired Controller - Order Code - XCONT-TR-CENT-COMFORT

- A wall-mounted wired controller (hereinafter referred to as the controller) can be connected to the unit as an accessory, which is used to fully control the unit. The controller allows you:
 - o Airflow control in 7 speeds
 - o To run the functions:
 - Intense ventilation – Boost
 - Night ventilation – start automatic night ventilation.
 - Customer menu to set individual unit parameters
 - o Signaling of unit error
- The controller is also supplied with a 10m connection cable, which is plugged into the controller at one end and equipped with an RJ connector (male) at the other end for connection to the unit.
- To connect the controller to the unit, follow these steps:
 - o Turn off the unit with the power switch
 - o remove the cap from the RJ connector (female) on the control plate on the unit.
 - o insert the end of the cable from the controller equipped with the RJ connector (male) into the RJ connector (female) on the control plate
 - o Turn on the unit and follow the manual for the wall controller – XCONT-TR-CENT-COMFORT



Pic. 43

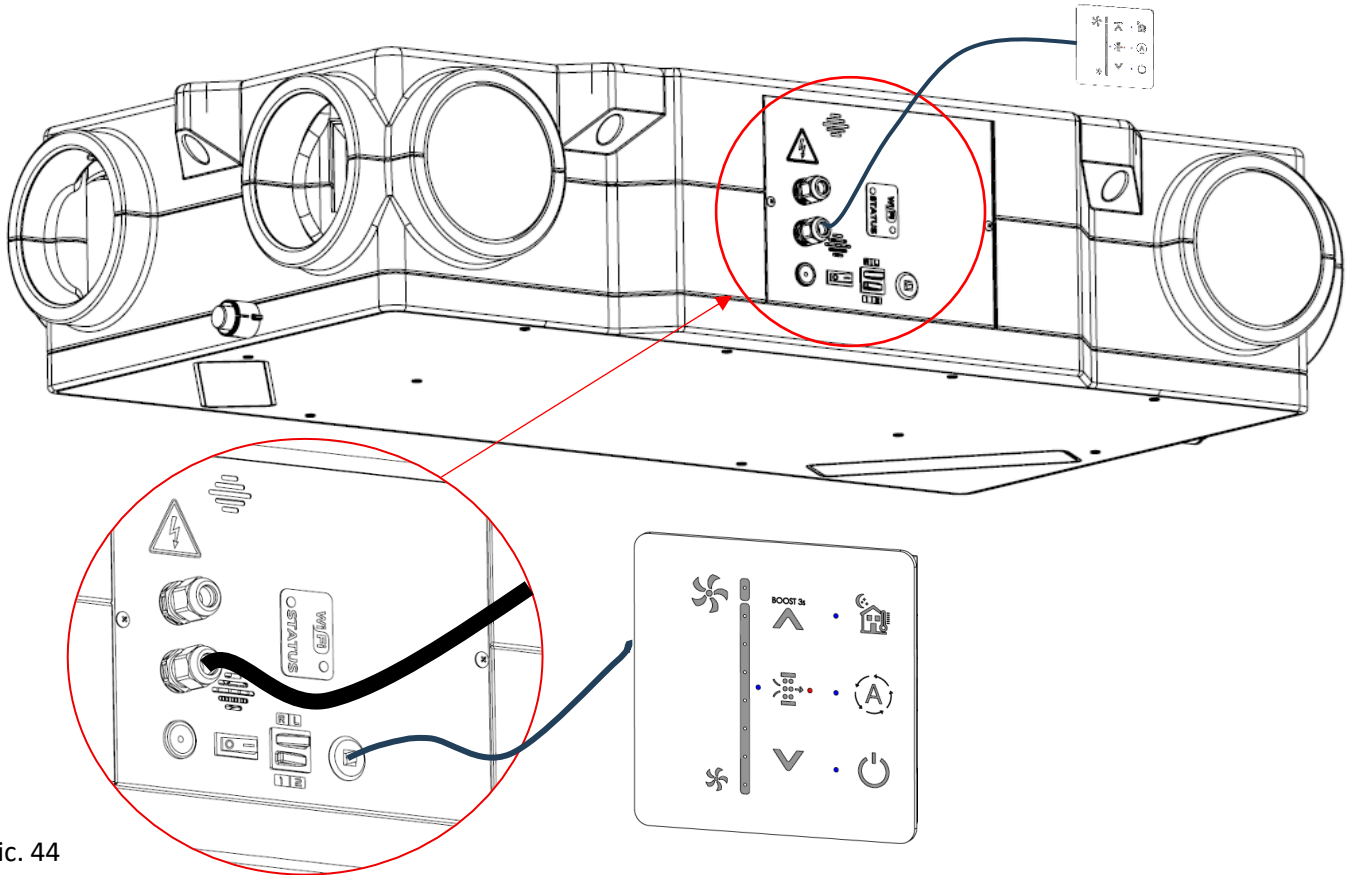

Pic. 44

- When combining several types of control – communication (e.g. WIFI, RF, BMS), each controller is equal and independent of the other, i.e. the controller that sends the last command to change the behavior of the unit, the unit behaves accordingly.



Driver installation and operating instructions are provided in the separate manual "MN-XCONT-TR-CENT-COMFORT", which is included with the accessory or is provided on the [website](https://www.xvent.cz/dokumentace)

4.3.2.2. Remote Wireless RF Controller – Order Code – RF-REMOTE-CONTROLLER

- A remote wireless RF controller (hereinafter referred to as the RF controller) can also be connected to the unit as an accessory, which is used to control the unit. The RF controller allows you to:

- Control of airflows in three speeds (Individual airflow speeds are always evenly recalculated according to the selected nominal flow)
 - Min (OFF)
 - mid
 - max (Boost 10min) – nominal flow
- Filter reset
- Signaling of unit error
- The range of the wireless RF controller is 50m in free space.
- To connect the RF controller, the pairing process with the unit control must be carried out according to the procedure:



- According to clause 4.3.1, remove the unit control cover
- On the control board, find the RF receiver (designation MOD1) – see the diagram in chapter 4.3.2.
- Pairing the receiver and RF controller

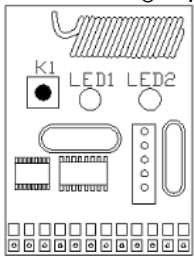

- On the RF receiver board, press the K1 button for 1 sec → LED 1 will light up blue → press the first button on the controller → LED1 will flash blue 3 times – the pairing process is complete

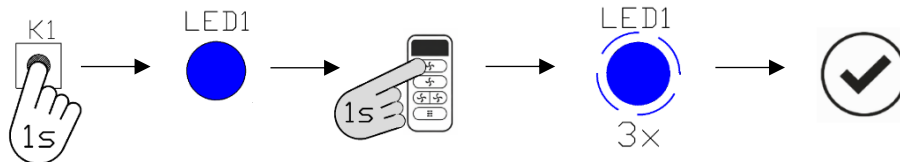

Pic. 46

- Checking the functionality of the RF controller connection to the unit

- Press any button on the RF controller → LED2 flashes red 2 times on the receiver board → the unit responds to the change → the connection between the RF controller and the unit is functional

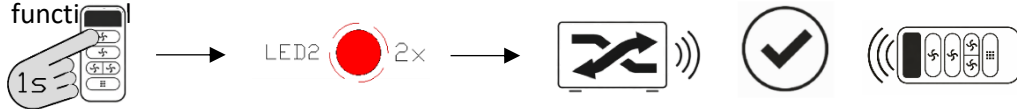

Pic. 47



○ If otherwise to clause 4.3.1, install the unit control cover

When combining several types of control – communication (e.g. WIFI, RF, BMS), each controller is equal and independent of the other, i.e. the controller that sends the last command to change the behavior of the unit, the unit behaves accordingly.



Installation and operating instructions are specified in the separate MN-RF-REMOTE-CONTROLLER manual included in the accessory delivery or on the <https://www.xvent.cz/dokumentace website>

4.3.2.3. Connecting the unit to the master BMS

- The unit is equipped with the possibility of connecting to a superior BMS system (hereinafter referred to as BMS) and an external WIFI module (in case the integrated WIFI module as separate accessories are not enough, e.g.: insufficient WIFI signal range). Communication with the unit is provided using the Modbus RTU communication protocol.
- The connection of the unit to the superior BMS must be performed by a qualified person knowledgeable in the field.
- The WifiModule connection and subsequent control of the web application must be done by a person with at least basic knowledge of PC technology and web browsers.

- To connect the unit to a superior BMS system or WIFI module, proceed as follows:



- First, turn off the power switch on the body of the unit
- According to clause 4.3.1, remove the unit control cover
- Run the communication cable through the free grommet in the control sheet – use the free screw grommet

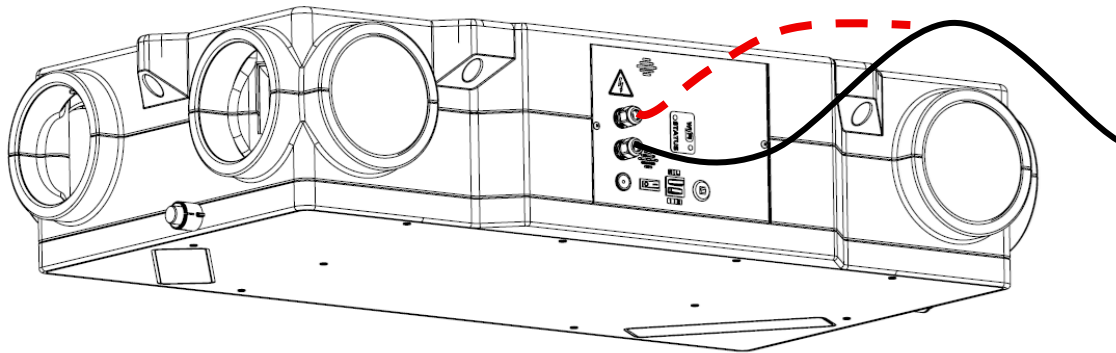

Pic. 48



Plug the communication cable into the connector marked 30 / 31 / 32 follow the wiring logic – see the diagram in chapter 4.3.2.

- When combining several types of control – communication (e.g. WIFI, RF, BMS), each type of control is equal and independent of the other, i.e. the controller that sends the last command to change the behavior of the unit, the unit behaves accordingly.



Communication of the unit with the superior BMS system is solved by the Modbus RTU communication protocol. Description of the protocol is addressed in the separate instruction manual "D-502-0707 - MN-ULTIMATE-MODBUS" - <https://www.xvent.cz/dokumentace>

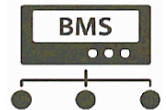

Pic. 49 BMS

4.3.2.4. Connecting AQS sensors

- Up to two AQS → AQS1 and AQS2 sensors can be connected directly to the unit control in any combination of CO₂, RH and Rn – Radon. Offer of AQS sensors according to the price list on request from the dealer.
- With the help of connected sensors, it is possible to operate the unit in automatic mode, which automatically controls the operation and air output of the unit according to the current need in the given space where the sensors are installed. At the same time, this method of control is the most effective in terms of operating economy – it is ventilated only according to the need that arises.
- Automatic mode is started directly in the WIFI module.eu web application or can be started by a button on the wired wall controller – XCONT-TR-CENT-COMFORT (not included – must be ordered as an accessory)
- Technical parameters of AQS sensors for connection to the unit:
 - 24VDC sensor power supply
 - Analog Output 0- 10VDC
 - Max sensor power consumption 5W
 - Analog Input Resistance Sensor 100kΩ
- Functionality of the unit after connecting AQS sensors:
 - The unit responds with smooth control to the need for ventilation triggered by real-time sensors:
 - When the concentration value of the monitored substances is reached, the ventilation is switched on to the minimum flow:
 - CO₂ – 800ppm,
 - RH – 65%.
 - Rn – 350 Bq/m³

- If the reduction of the concentration of the monitored substances in the room is not achieved, the control of the unit increases the flow rate up to the maximum flow value set by the user.
- The unit control will start to continuously decrease the flow again as the concentration decreases.
- The goal of the control – ventilation, is to find the ideal degree of ventilation (flow) depending on the concentration of the monitored substance in the ventilated room. For this reason, the unit can ventilate for a long time until it reaches a safe concentration limit or complete ventilation of the monitored substance.
- When the concentration is reduced to the specified value, the ventilation is switched off and goes into readiness mode:
 - CO2 – 700ppm,
 - RH – 60%.
 - Rn – 250Bq/m3
- When there is a requirement for ventilation from more sensors, the control prefers the sensor with a higher ventilation requirement.
- The setting of the switching level of ventilation and the type of AQS sensors can be changed in the service application (intended for authorized technicians) or in the higher-level BMS system (Modbus RTU).

- Connecting AQS sensors to the unit control



- First, turn off the power switch on the body of the unit
- According to clause 4.3.1, remove the unit control cover
- If wired sensors are used, pass the connecting cable through a grommet with a rubber diaphragm in the control housing
- Connect the AQS sensors according to the diagram – see the diagram in chapter 4.3.2.



- Setting the sensor type AQS1 and AQS2

- The sensor type is set directly in the control by changing the clamp setting (jumper) in the field marked as JP2 and JP4 – according to the diagram. The options for choosing the AQS sensor type are:

▪ AQS1 Input

- JP2/A – **CO2/RH** switching
- JP4/A – **CO2+RH** / Rn-radon switching

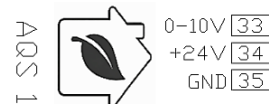

Pic. 50

▪ AQS2 input

- JP2/B – **CO2/RH** switching
- JP4/A – **CO2+RH** / Rn-radon switching



Pic. 51

- Factory settings – values marked in bold



- **When setting the AQS sensor type using the service application (intended for authorized technicians) or in the superior BMS system (Modbus RTU), the setting directly in the control does not work.**

- To connect multiple sensors from one variable, it is possible to use the accessory "Signal combiner for air quality sensors" - PRO-SUM-08-D-P111

- With this accessory you can connect up to 8pcs of sensors from of one parameter to one input on the control board (e.g.: 1pc combiner = 8pcs CO2)



- **Sensors from only one variable must be connected to one accessory of the PRO-SUM-08-D-P111 combiner, never in combination. Otherwise, there is a risk of poor evaluation of the measured concentration of the variable and the behavior of the unit**

4.3.2.5. Connecting an external contact EXT1 – ON/OFF

- The unit control allows the connection of an external contact for remote switching (on/off) of the unit (remote control ON/OFF).
- The external contact is designed as potential-free and can be switched on, for example:

- By means of a magnetic door contact (contact used for security systems). The contact can be mounted, for example: on a window. If the window is opened, the unit stops, and when the window is closed, the unit starts up again.
- Using a remote switch. Electrical appliances in the building are switched off with one button (total stop system). A unit using this contact can be included in this system.
- Using a time relay. The unit can be switched on/off by a time relay located in the control cabinet.
- Technical parameters of the EXT1 external contact



- o Switching voltage 24VDC / 5mA
- o The contact can change the switching logic by switching the clamping bridge to the NC or NO switching logic (factory setting) – see the article below "connecting EXT1 to unity control"

Functionality of the unit when controlled by an external EXT1 contact

- o An external contact switches the unit on and off with a logical termination or switching on of all running processes at the time of shutdown, switch-on.
- o If the unit is turned on/off by an external contact, it can be turned off/on using the web app, BMS (if installed), or accessories:
 - Wall Wired Controller - Order Code - XCONT-TR-CENT-COMFORT
 - Remote Wireless RF Controller – Order Code – RF-REMOTE-CONTROLLER
- o An example of how an external contact works – a timer is used as an external contact:
 - EXT1 turns on the unit at a given time (morning) – the unit works according to the user's settings,
 - during operation, the unit is switched off by the controller on the unit – the unit turns off,
 - EXT1 turns off the unit at a given time (evening) – the unit remains switched off all the time,
 - EXT1 turns on the unit at the given time (the next morning) – the unit works according to the user's settings.

- Connecting EXT1 to the unit control

Pic. 52



- o First, turn off the power switch on the body of the unit
- o According to clause 4.2.3.1, remove the control cover of the unit
- o Pass the cable for the connecting cable with the control through the grommet with a rubber membrane in the control housing
- o Connect the external contact EXT1 according to the diagram – see the diagram in chapter 4.3.2.



- Set up the EXT1 switching logic
 - o The setting of the switching logic of the external contact is made by changing the "jumper" (clamp) settings in the field marked as JP1/E – according to the scheme. Setting options:
 - Closed contact – NC – jumper, clamp not attached
 - Open contact – NO – jumper, clamp on – factory settings

4.3.2.6. Connecting an external EXT2 – Boost contact

- The control of the unit allows the connection of an external button (switch with automatic return of the flap – e.g.: bell button with return spring) to start the boost ventilation mode for a set period of time – BOOST (hereinafter referred to as BOOST)
- The BOOST mode is designed for sudden ventilation for a certain period of time in areas with an immediate need for ventilation, e.g.: bathroom, toilet, etc...
- Boost mode can also be started without connecting an external button directly in the web app or using accessories:
 - o Wall wired controller – order code – XCONT-TR-CENT-COMFORT – adjustable run time (factory setting - 1 min)
 - o Remote Wireless RF Controller – Order Code – RF-REMOTE-CONTROLLER – for 10min
- Technical parameters of the external contact – Boost
 - o External contact is designed to be potential-free
 - o Switching voltage 24 VDC / 5mA.

- Functionality of Boost mode triggered from a connected external button
 - o When a button is pressed (a switch with automatic flap return), the BOOST mode is activated
 - The BOOST mode is turned on and the unit starts at the set air power and run time of 1min
 - When the set run time of the BOOST mode ends, the unit returns to the previous mode
 - o If you want to exit BOOST mode before the run time is set.
 - Hold the button for about 2sec
 - BOOST mode will automatically stop and the unit will return to its previous mode
 - o To factory set the BOOST mode when booting up using an external button:
 - Air power in BOOST mode – max air power of the unit
 - BOOST Mode Duration – 1 min

- You can change the Boost mode settings in the web app

- Connecting EXT2 – Boost to Unit Control

Pic. 53



- o First, turn off the power switch on the body of the unit
- o According to clause 4.3.1, remove the unit control cover
- o Pass the connecting cable with the control through the grommet with a rubber membrane in the control housing
- o Connect the external contact EXT2 – Boost according to the diagram – see the diagram in chapter 4.3.2.

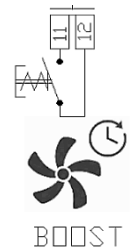

- Pass the communication cable to connect the unit to the BMS and the WIFI module through a free grommet
- The unit must be connected to the BMS and the WifiModule using a UTP cable equipped with terminals – RJ45 8/8 connectors. The RJ connectors on the UTP cable must be wired as a direct connection (both connectors are connected equally).
- Setting the EXT2 switching logic
 - o The setting of the switching logic of the external contact is done by changing the "jumper" (clamp) settings in the field marked as JP1/D – according to the scheme. Setting options:
 - Closed contact – NC – jumper, clamp not attached
 - Open contact – NO – jumper, clamp on – factory settings

4.3.2.7. External Electric preheater – (PREHEATER) – Order Code – see pricelist

- It is possible to connect an external electric heater – preheater with a maximum power of 1600W, a maximum current of 7A and a voltage of 1x230V.
- Recommended Heater Power 1000W
- The preheater power supply is solved directly from the control board of the unit with wiring
 - o Phase L – Terminal 70
 - o Neutral N – Clamp 71
 - o PE ground wire – Wago terminal led out of the ground bridge
- The preheater switching logic is subordinated to the temperature on the anti-frost sensor, which is located in the recuperator of the unit and senses the actual freezing temperatures of the unit.
- If the preheater is not sufficient to defrost the heat recovery exchanger, additional anti-frost logics are triggered along with the switched on preheater.
- The unit control cannot detect the presence of an external preheater, so it assumes that it is always connected. If the external preheater is not connected, the heat exchanger is protected against freezing by other anti-frost logics.
- We recommend using a non-regulated heater with direct connection to the control of the unit with safety thermostats. The heater control is replaced by a unit control with the ON/OFF type of switching (100% power / 0% power).
- For trouble-free and long-term operation of the external preheater, we recommend using a filter box to collect coarse dirt before preheater.
- **Nothing other than external preheater must be connected to the terminals of the power supply – resistance load with a maximum nominal value of 1.6kW / 7A / 230V**

Pic. 54



- Connecting external preheater to the unit control
 - o First, turn off the power switch on the body of the unit
 - o According to clause 4.2.3.1, remove the control cover of the unit
 - o Pass the cable for the connecting cable with the control through the grommet with a rubber membrane in the control housing
 - o Connect the preheater according to the diagram – see the diagram in Chapter 4.3.2.

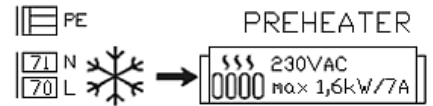

- **Install the heater – preheater according to the instructions of the heater manufacturer, e.g.: flow direction, distance from the unit, position of the heater, distance of the temperature sensor from the heater, etc.**
- **If the heater manufacturer requires compliance with the minimum speed in the duct for the proper functioning of the heater, it must be solved by a separate component (e.g.: differential pressure sensor). The unit must not be used for this purpose under any circumstances. The manufacturer of the unit is not liable in any way for improper installation, possible malfunction or damage caused by the heater.**

4.3.3. Connecting an external electric postheater – (POSTHEATER) – Order Code – see pricelist

- An electric postheater is a separate heating system that is used to heat the exhaust air into the building (reheating the differential heat output)
- The electric postheater is not connected to the control with the unit in any way = it does not control it in any way
- The recommended power of the electric postheater is 600W
- We recommend using a heater with a channel sensor for separate temperature control
- **Consult the correct design of the optimal performance of the heater with an ventilation designer or a person familiar with this issue with regard to the specific installation and possibilities in the building.**
- **The supply wiring to power the postheater must be solved by a separate supply, in no case can the postheater be powered from the unit.**
- **Install the heater – postheater according to the instructions of the heater manufacturer, e.g.: flow direction, distance from the unit, position of the heater, distance of the temperature sensor from the heater, etc.**
- **If the heater manufacturer requires compliance with the minimum speed in the duct for the proper functioning of the heater, it must be solved by a separate component (e.g.: differential pressure sensor). The unit must not be used for this purpose under any circumstances.**
- **The manufacturer of the unit is not liable in any way for improper installation, possible malfunction or damage caused by the heater.**



5. Commissioning

5.1. Before you run for the first time, check:



- that all installation work has been duly completed as indicated in Chapter 3.
- that the power cord of the unit is properly connected to the mains,
- If there is a WiFi network that has access to the Internet to which you will log the unit
- If you know the WIFI network name and password to log in the unit
- whether the connected electrical accessories are plugged in correctly
- whether the condensation siphon is watered and the condensate outlet is connected to the sewer system
- whether the unit contains clean filters

5.2. Getting the unit up and running



- **For successful commissioning of the unit, a WIFI network with Internet access must be available in the installation area, it is necessary to know the name of the network and password to access it.**
- **Check that the security of your WIFI network allows you to connect another device – a unit. If you allow the connection of another device – drives, please discuss with your network administrator.**
- **To put the unit into operation, ensure a device that allows connection to the WIFI network – the Internet, contains a web browser and is ideally equipped with a webcam – smartphone, tablet, laptop**
- **If you do not have a WIFI network with internet access or a device that would be suitable according to the previous point, you can put the unit into operation using the accessories:**
 - o **Wall Wired Controller - Order Code - XCONT-TR-CENT-COMFORT**
 - o **Remote Wireless RF Controller – Order Code – RF-REMOTE-CONTROLLER**

5.2.1. Turning on the unit



- Switch the power switch from position 0 (OFF) to position 1 (ON) and wait for:
 - o The STATUS LED turns solid blue – the unit is powered but turned off (OFF). Detailed description of WIFI statuses in a separate chapter 5.3.2.
 - o The WIFI LED will start flashing cyan – the unit is ready for pairing. Detailed description of WIFI statuses in a separate chapter 5.3.2.

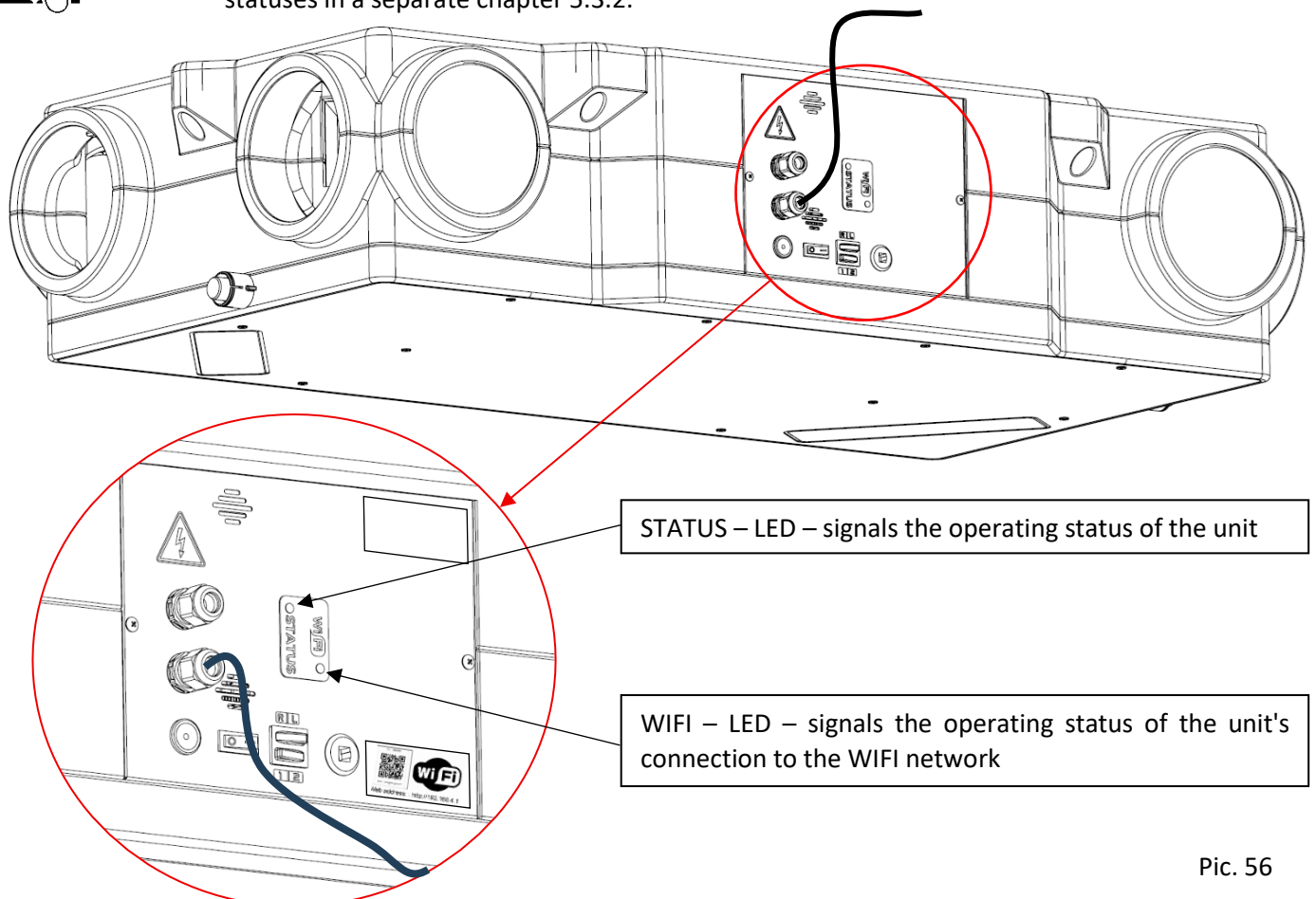

Pic. 56

5.2.2. Create an account in the WIFImodule.eu web app

- To put the unit into operation, you need to create your user account using the web application (hereinafter referred to as the APP) at WIFImodule.eu to control the unit.
- The APP is created as "native" → i.e. it adapts to any device that contains a web browser and has access to the Internet.
- To create a user account, proceed as follows (instructions are displayed in smartphone resolution):

1

In your web browser, enter the web address www.WIFImodule.eu

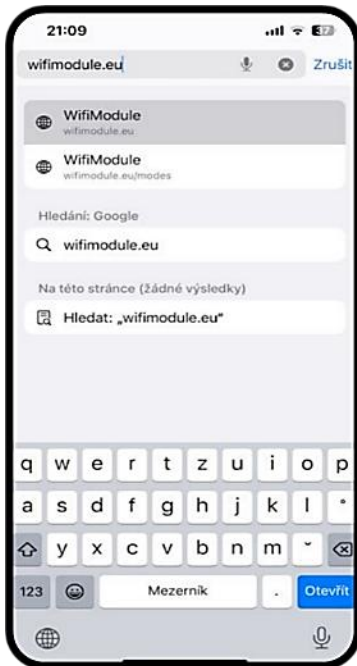

2

Open a new account
In the case, you can check out the video tutorial by clicking the help icon 

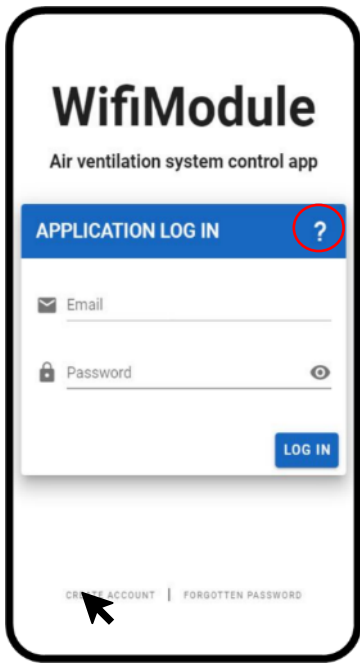

3

Enter your registration email address. Choose an address that you use frequently – the unit will send notification messages

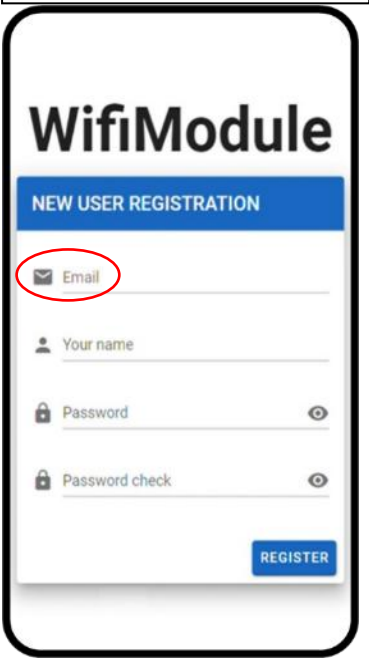

4

Enter your name

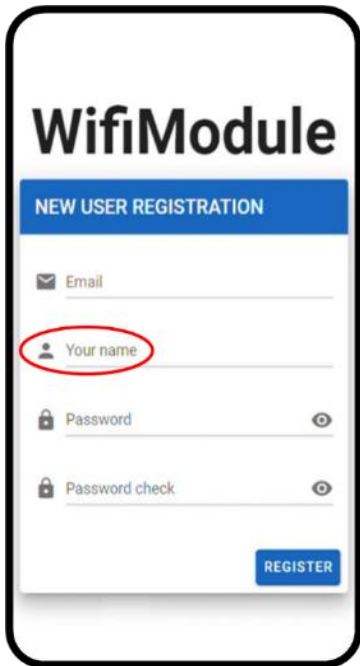

5

Enter the password to log in to the application.
To view the password, click 

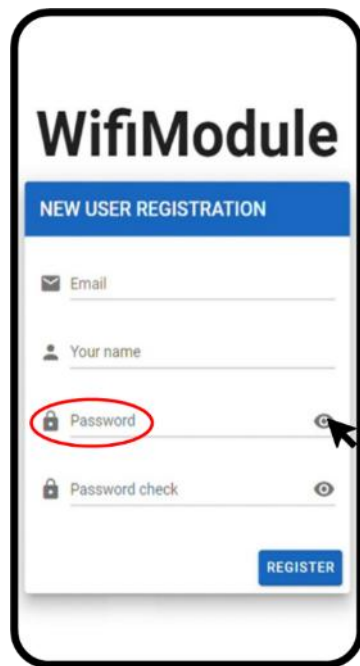

6

Enter your password again.
To view the password, click 



7 Confirm registration

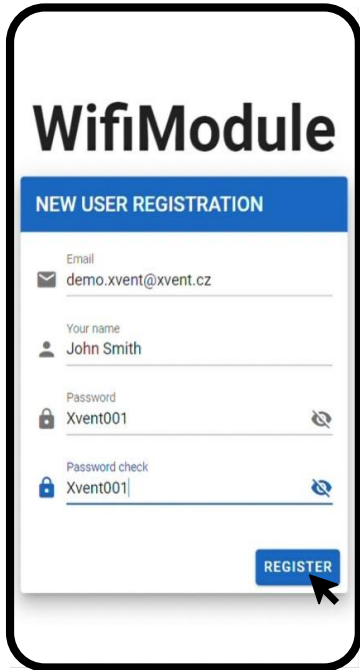

The screenshot shows a mobile application interface for 'WifiModule'. At the top, it says 'NEW USER REGISTRATION'. Below this, there are four input fields: 'Email' with the value 'demo.xvent@xvent.cz', 'Your name' with 'John Smith', 'Password' with 'Xvent001', and 'Password check' with 'Xvent001'. Each field has a small eye icon to toggle visibility. At the bottom right, there is a blue 'REGISTER' button with a mouse cursor pointing to it.

8 After successful registration, a confirmation email will be sent to the registration email address provided.

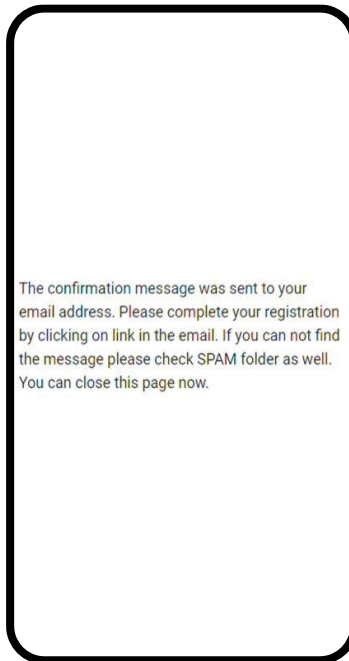

The screenshot shows a confirmation message: 'The confirmation message was sent to your email address. Please complete your registration by clicking on link in the email. If you can not find the message please check SPAM folder as well. You can close this page now.'

5.2.3. Confirmation of the registration email

- After successful registration, you will receive a confirmation email to the registration email address in the

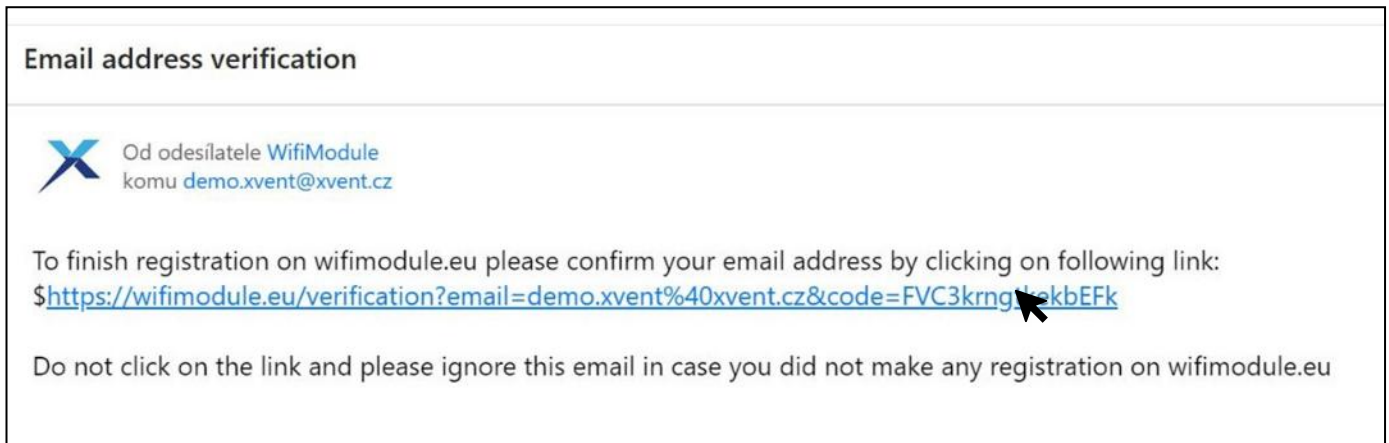

The screenshot shows an email titled 'Email address verification'. It features the Xvent logo and text: 'Od odesílatele WifiModule komu demo.xvent@xvent.cz'. The main body of the email says: 'To finish registration on wifimodule.eu please confirm your email address by clicking on following link: <https://wifimodule.eu/verification?email=demo.xvent%40xvent.cz&code=FVC3krngjkbEFk>'. A mouse cursor points to the link. At the bottom, it says: 'Do not click on the link and please ignore this email in case you did not make any registration on wifimodule.eu'.

- To complete the registration, you must confirm the link provided in the email 

5.2.4. Log in to the app

1 Return to the www.WiFiModule.eu website

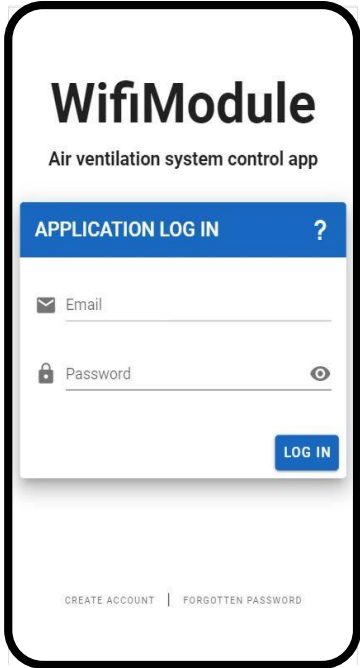

2 Fill in the registered email

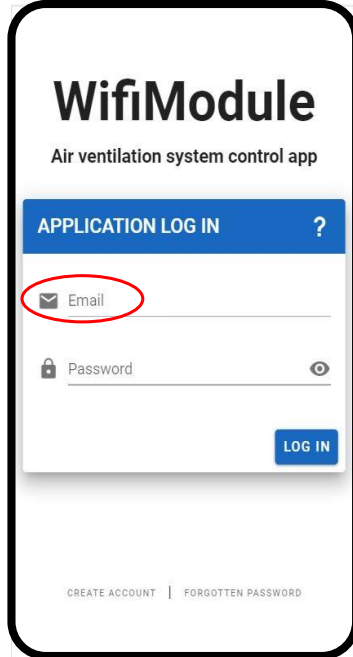

3 Enter your password
To view the password, click 

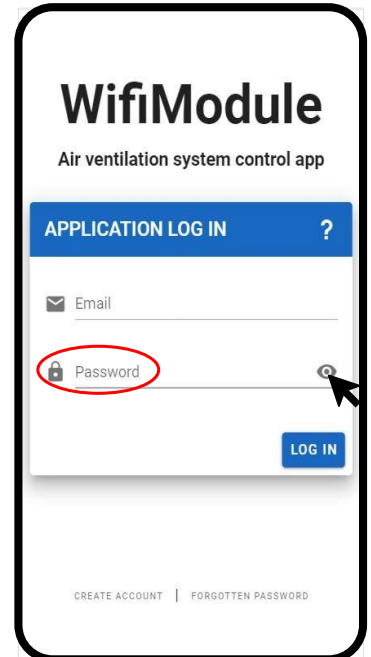

4 Confirm 

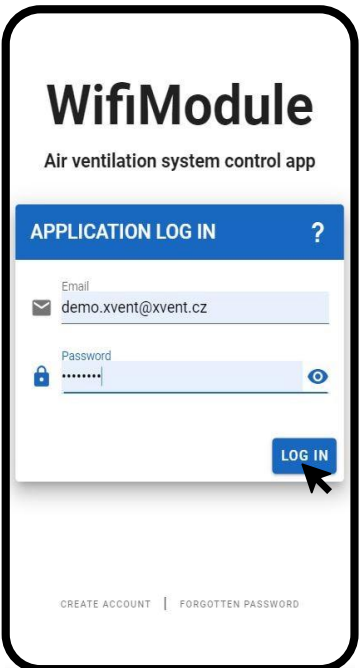

5 You have successfully logged in to the application

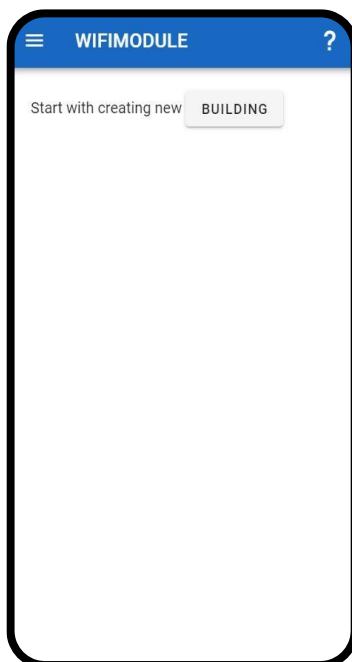

5.2.5. Initial application setup

5.2.5.1. Setting up of the building

1 Establish – name the building (room, apartment) that the unit will serve

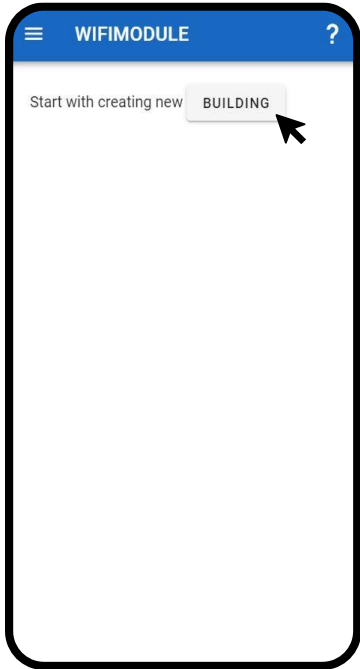

2 Name the building (apartment) that the unit will serve

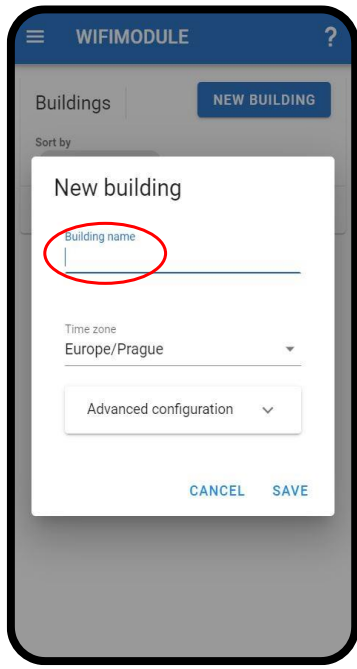

3 Select the nearest time zone you are in

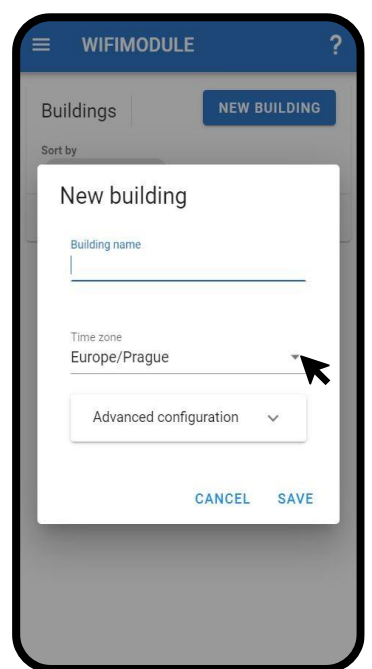

4 !!! Advanced settings – set only if you are aware of what you are doing!!

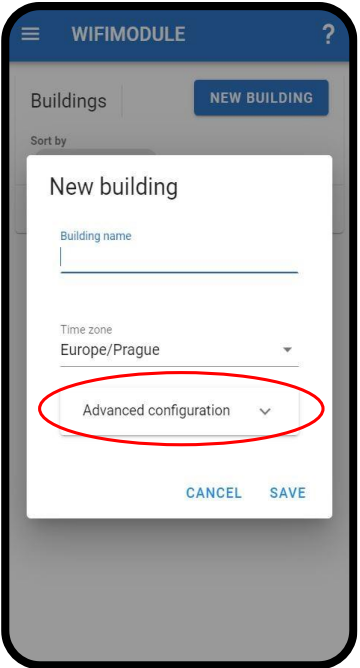

5 Save settings
It is possible to return to the building settings at any time.

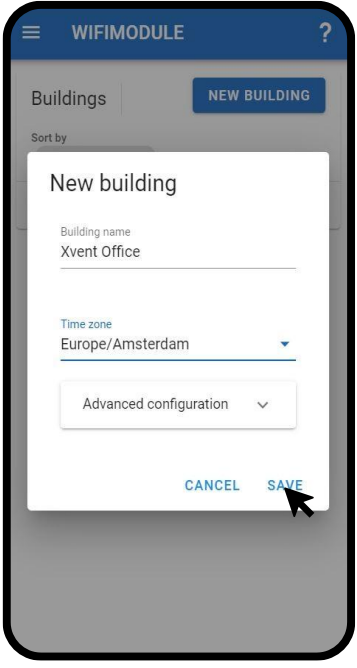

6 The building is successfully created and named
You can establish another building if necessary

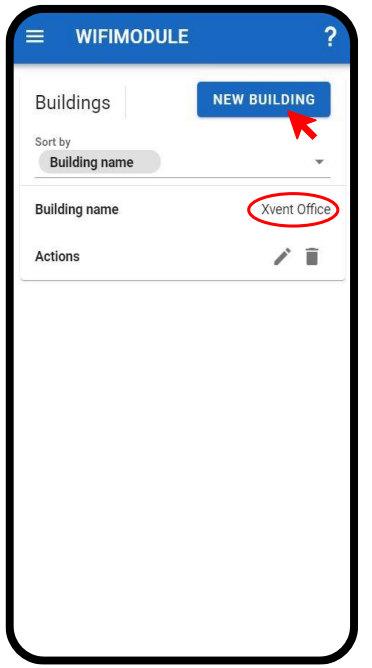

5.2.5.2. Add a unit

7 Menu

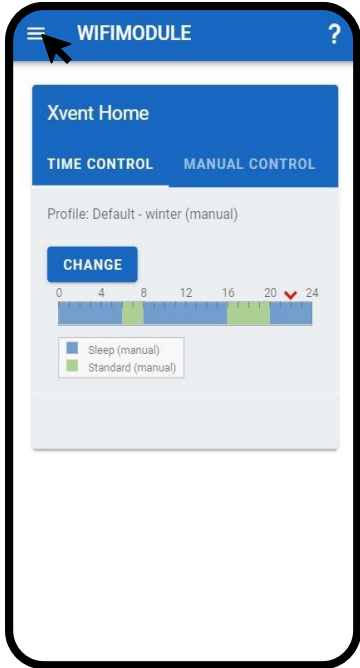

8 Settings

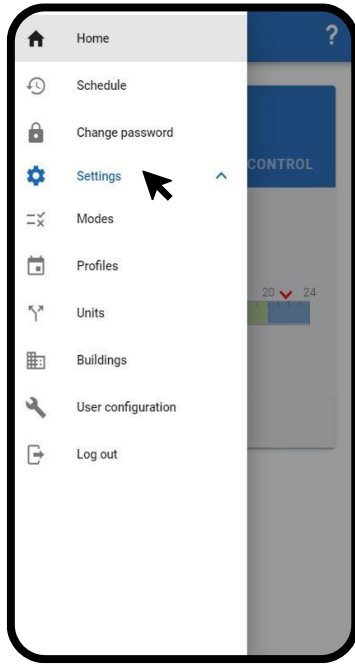

9 Units

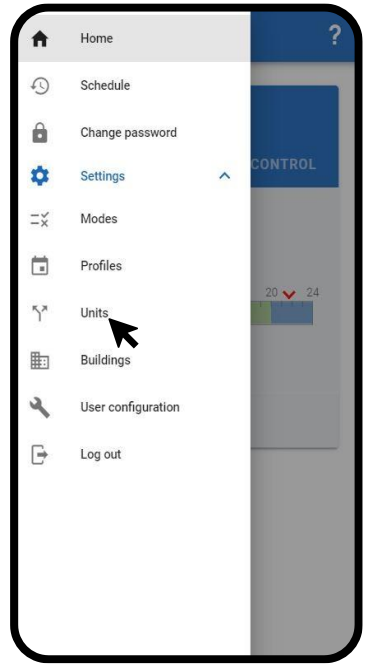

10 New unit

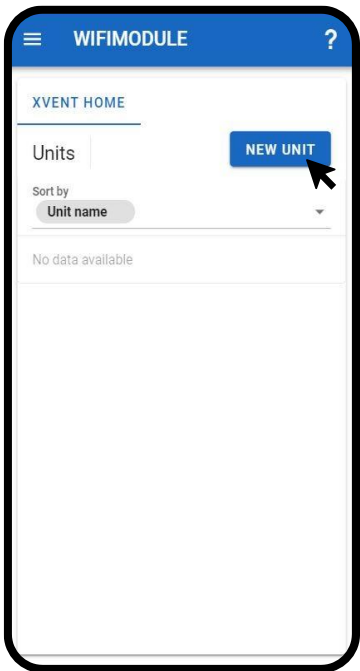

11 Allow your device to access the camera – the camera
Name the unit

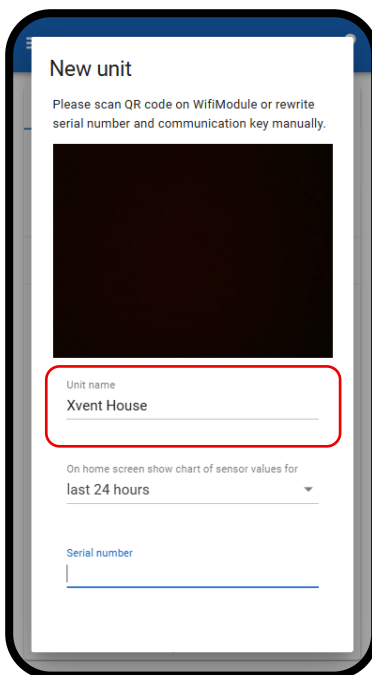

12 Set the time it takes to view the AQS sensor concentration overview chart

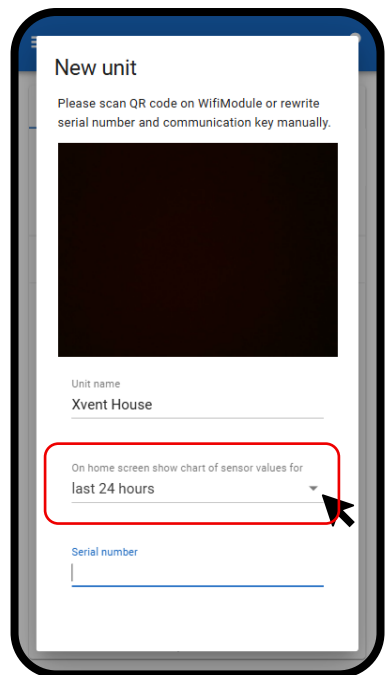

13

- Use the camera on your device to scan the QR code located on the control plate
- QR code - the code is automatically loaded into the app
 - o Serial number – SN:
 - o Key – KEY:
- In case of unsuccessful loading, (damage to the QR code) or if the device is not equipped with a web camera, enter the data manually directly into the application
- Save your settings

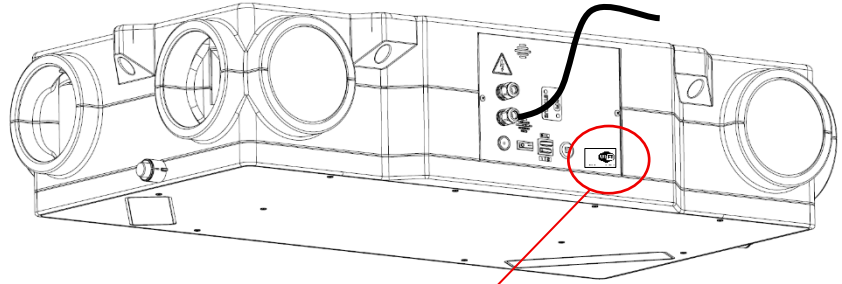
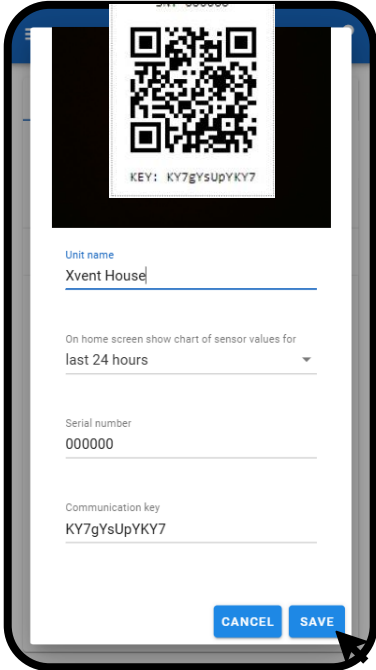

Pic. 57

- In the event of loss or damage of the label to such an extent that it is not possible to read the QR code or read the written data, a backup label is placed on the control board. To access it, follow these steps:
 - o Turn off the power switch on the body of the unit
 - o According to clause 4.3.1, remove the unit control cover
 - o Read or copy the data from the backup QR – code that is located on the WIFI control module

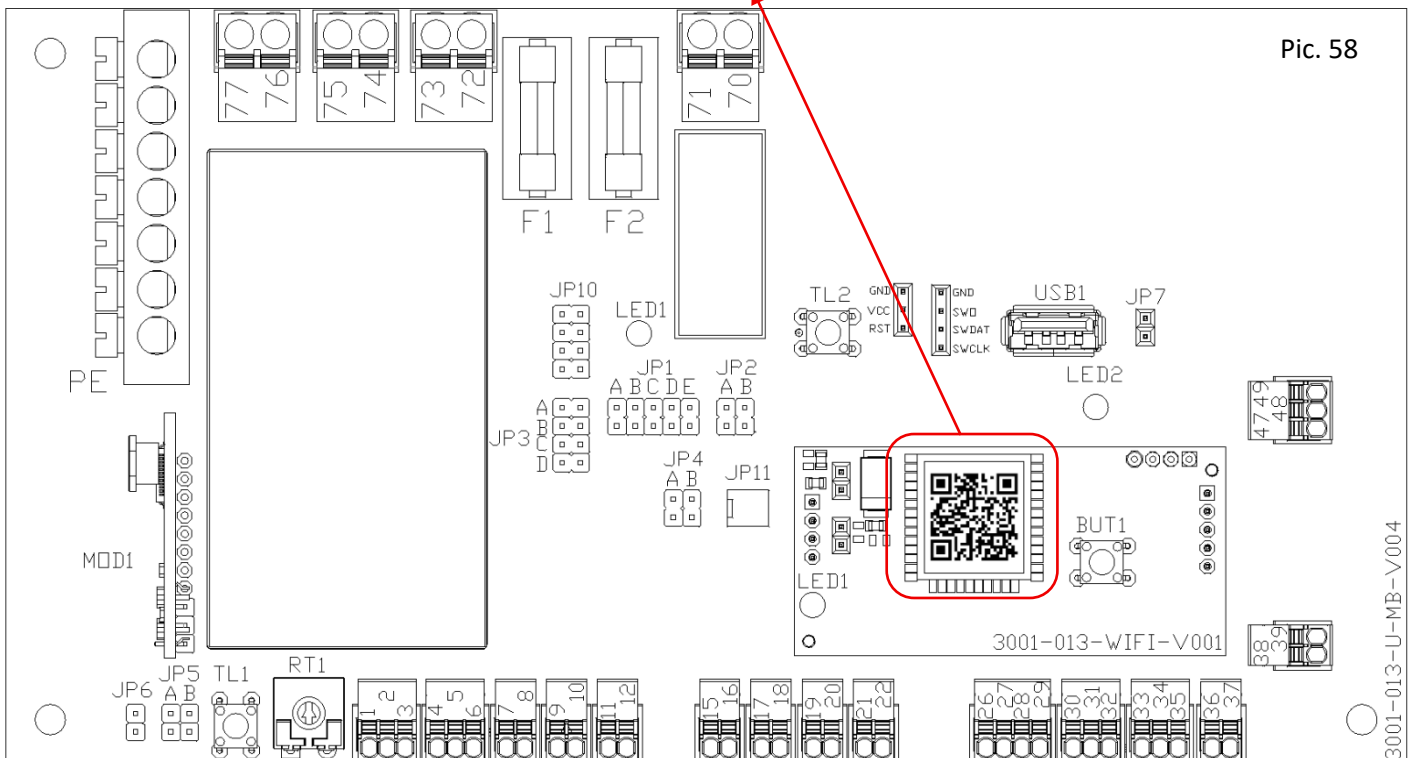

Pic. 58

5.2.6. Pairing the unit with the app – APP



- The following procedure assumes the fulfillment of the points from the previous chapters. If you have skipped one, you must repeat it, otherwise you cannot continue with the next procedure.

1

- Check that the WIFI STATUS LED is flashing cyan
- Unit is ready for pairing

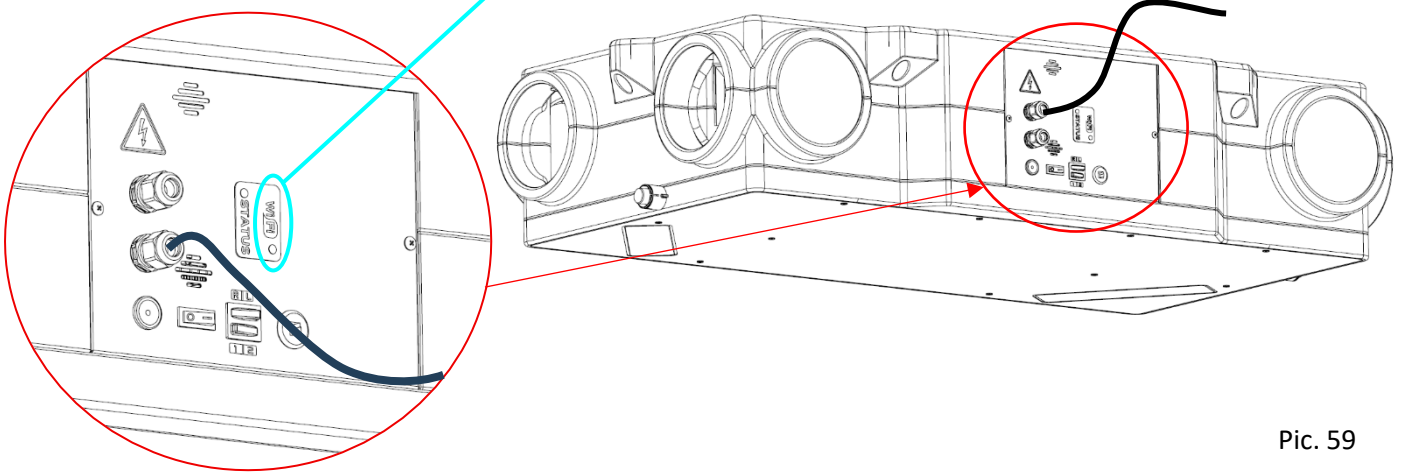

Pic. 59



- If the WIFI STATUS LED indicates otherwise, you need to restart pairing mode – follow these steps:

- o Turn off the unit with the power switch on the unit control cover
- o With added caution, remove the unit control cover according to clause 4.3.1
- o Turn on the unit's power switch on the open enclosure – TAKE EXTRA CARE – the unit is powered at 230V when resetting to pairing mode. Alternatively, contact an electrical technician with a valid license.
- o Wait for the WIFI STATUS LED to light up or flash – in any color
- o On the WIFI module, press the BUT1 button for about 5 seconds.
- o After approx. 5sec, the WIFI STATUS LED will start flashing cyan – pairing mode

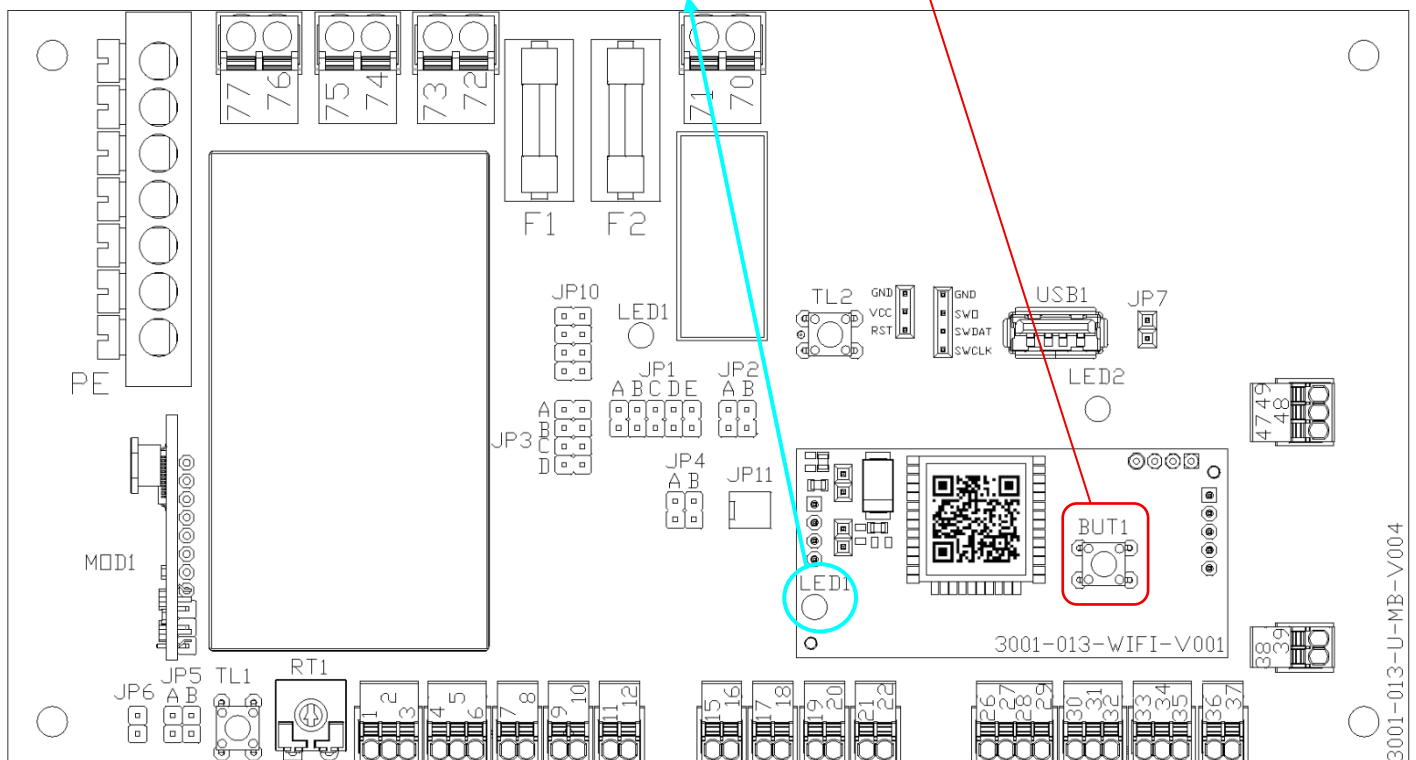

Pic. 60

- o Leave the control open until you have completed the entire pairing process mentioned in this article. Then turn off the unit with the main switch and install the control cover back.

2 - On your device, find a WIFI network with a name that matches the serial number of your unit – SN: 000000
 - the name of the network is indicated on the control cover next to the QR code

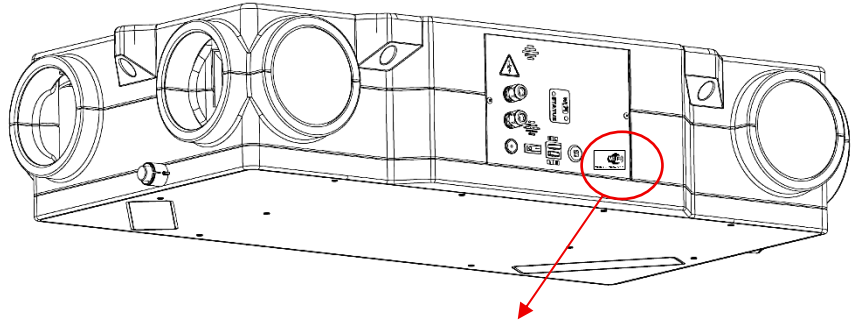
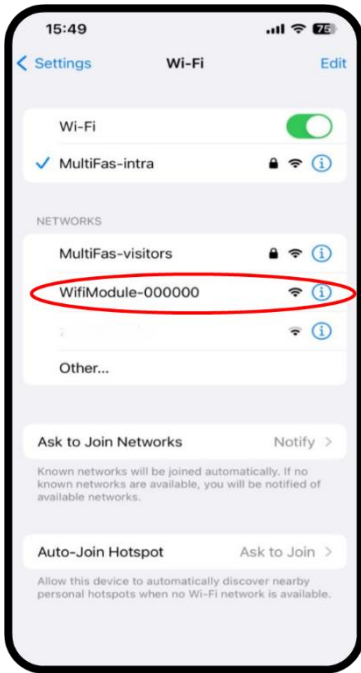

Pic. 61

3 Connect to this WIFI network – the network is without connection and internet

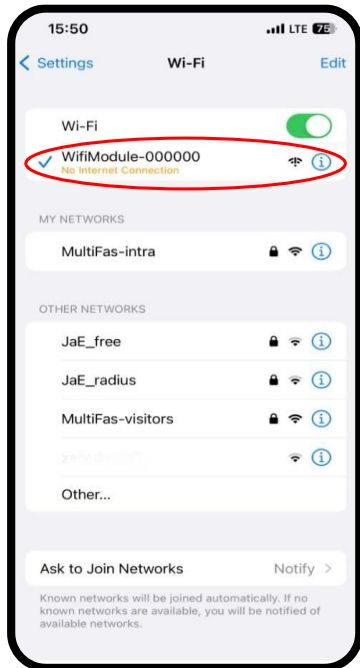

4 In your web browser, enter the web address 192.168.4.1, which is listed below the sticker with the QR code

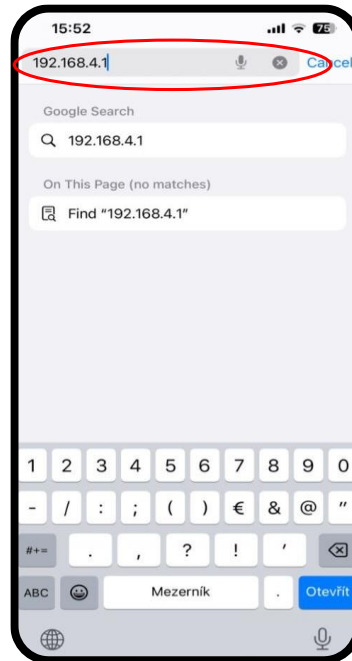

5 Find your WIFI network to which the unit will be permanently connected

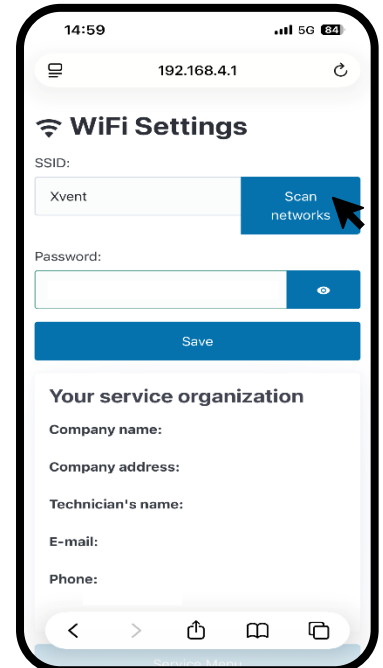

6 Enter the password for your network to which the drive will be connected
Click to view

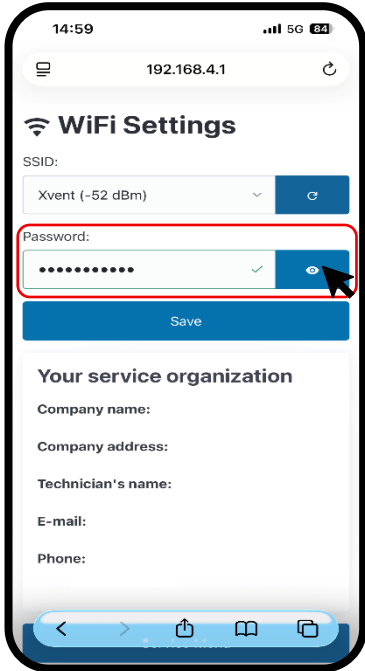

7 Confirm the settings

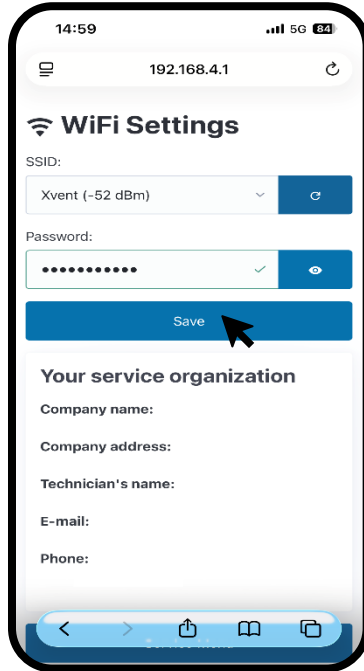

8 Close the WIFI network settings website

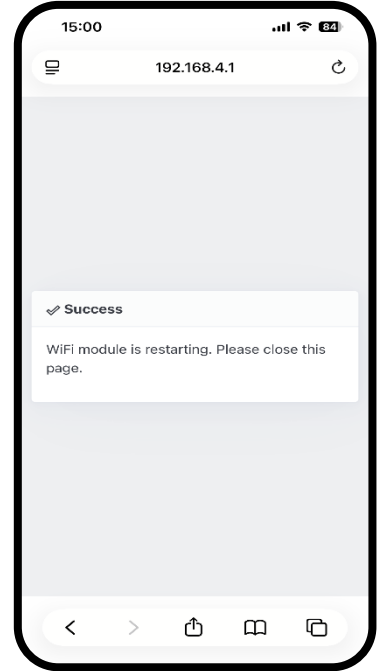

9 The WIFI LED starts to turn solid green light (flashing green – weak WIFI network signal) – the pairing process can take up to 10ces

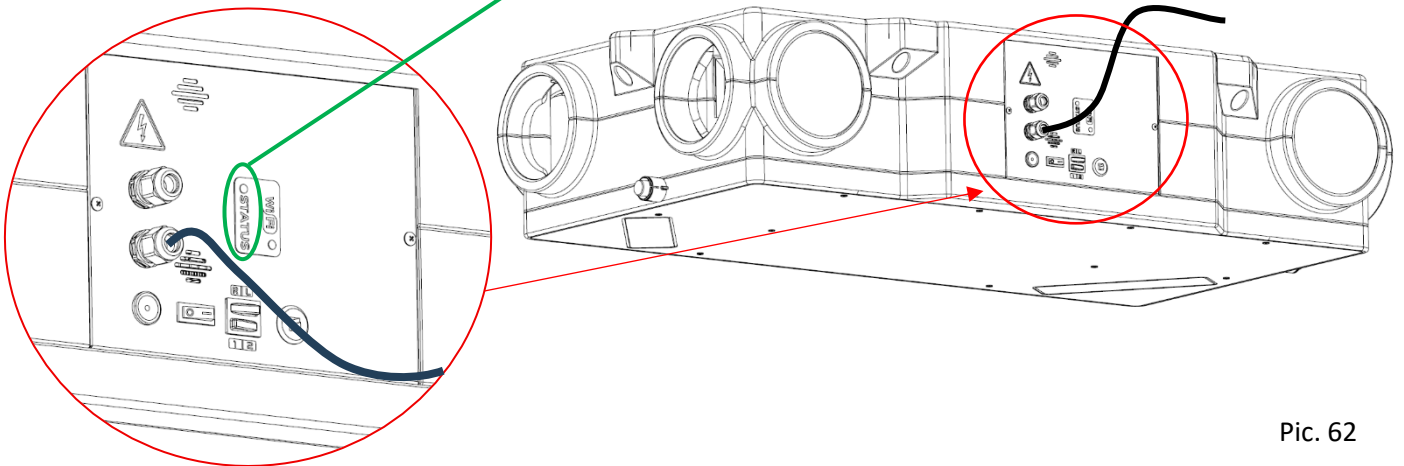

Pic. 62

- The pairing process is complete, you can now control the heat recovery unit using the web app WIFImodule.eu



If pairing fails, repeat the process – Chapter 5.2.6.

If you had to reset into the pairing mode, then after the pairing mode is complete - the WIFI LED is green (flashing green - weak WIFI network signal) and you still have the unit's control cover open, then proceed as follows:

- Turn off the unit with the power switch on the unit cover
- Reassemble the control cover
- Turn the unit back on with the power switch on the unit cover

5.2.7. Verification of unit functionality and control



The unit is from factory turned off – OFF, the following installation steps must be completed to verify functional control:

- You must have a user account – Chapter 5.2.2.
- The unit must be paired with your account and connected to a WIFI network with internet – the WIFI LED is green (flashing green – weak WIFI signal) – Chapter 5.2.6.
- The unit must be turned on with the power switch – the STATUS LED is solid blue



If all of the previous steps were met, follow these steps:

- Open the www.WIFImodule.eu website
- Log in to your established account
- The application will switch you to the home page – the basic screen, if everything is correct, you can see:
 - Connecting the unit with the currently set mode of operation – calendar in the default settings
 - Connected Unit Operating Status
- Switch to manual control
- Select 2nd gear on the fan scale.

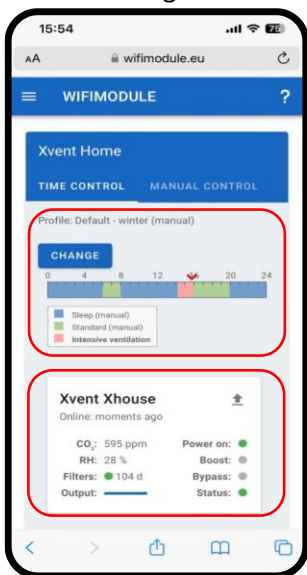

Pic. 63

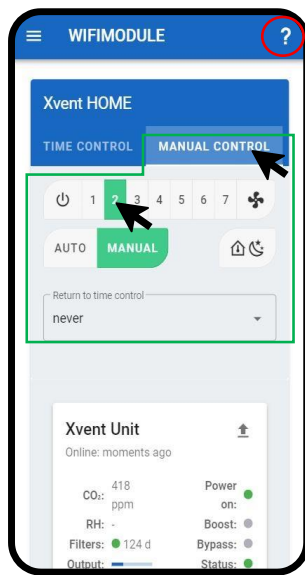

Pic. 64



For faster access to control the unit, we recommend creating a shortcut to the desktop of your device from which you will control the unit.

- The STATUS LED turns green (unit in operation) – the unit will start in 2nd gear.
- Physically check that the unit is in operation, if so, the commissioning of the unit is complete

5.3. Basic description of controlling the unit via APP

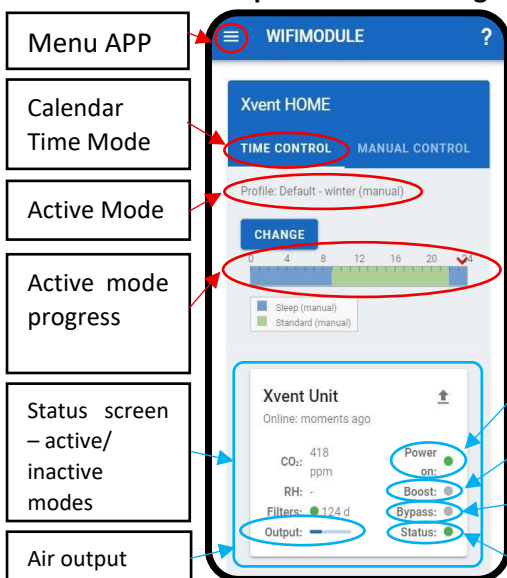

Pic. 65

- Menu APP
- Calendar Time Mode
- Active Mode
- Active mode progress
- Status screen – active/inactive modes
- Air output

- ON/OFF
- Boost
- Bypass
- Unit Status

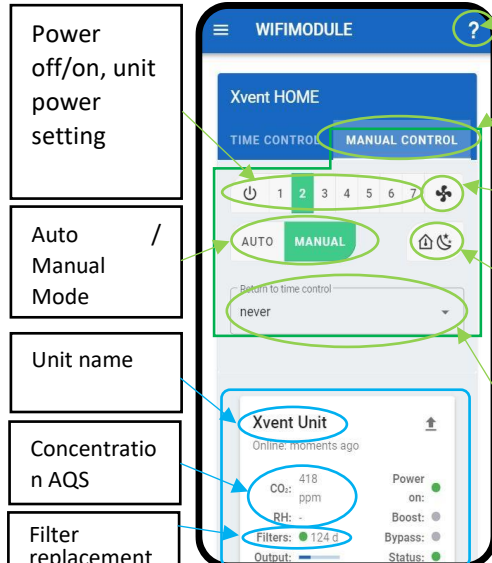

- Help
- Manual mode
- Boost
- Automatic bypass
- Setting the Run Time of Manual Mode

Pic. 66

- To use all the options of the APP settings, use the help (link to the video) listed under the symbol

- The full description of all APP settings and functions is described in the separate manual "Control – WiFi module – APP."

5.3.1. Setting the air output of the unit

- In the APP, in the manual control tab, you can set the power level of the unit

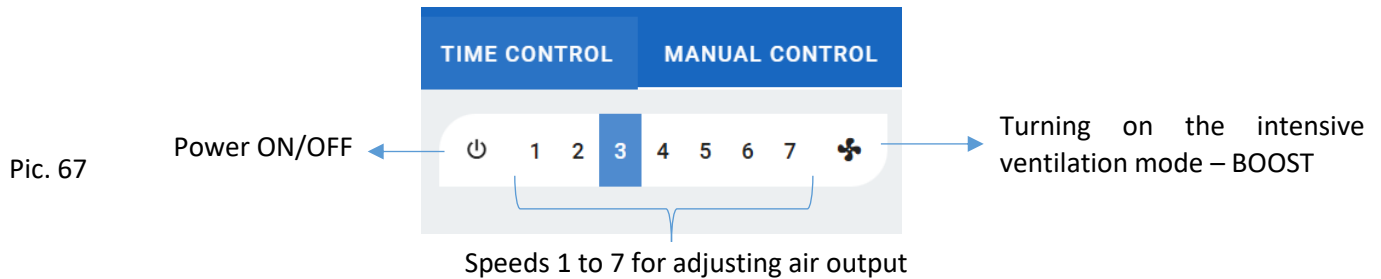

- Setting of individual air outputs according to the type of unit – factory settings

Tab. 16

Unit type	XF2-035-ECS0xxxxx-xxx		XF2-045-ECS0xxxxx-xxx	
Airflow level in APP	Nominal airflow	Nominal airflow	Nominal airflow	Nominal airflow
	300 m ³ /h	350 m ³ /h	400 m ³ /h	450 m ³ /h
	m ³ /h	m ³ /h	m ³ /h	m ³ /h
1	70	70	110	110
2	100	105	143	152
3	133	145	183	200
4	174	198	228	256
5	218	246	284	319
6	257	290	337	387
7*	300	350	400	450
Boost	350	390	450	450

* Nominal airflow at an external pressure drop of 200 Pa



- **Nominal flow setting (up to 70% of the nominal flow rate from the unit's factory settings) can also be done using the service app (intended for authorized service technicians only). In the case of setting the nominal flow rate using the service application, the settings on the individual power levels will not correspond to the advertised values, but they will calculate evenly (the minimum power is fixed).**

5.3.2. Description of the operating states of the unit – signals of the STATUS LED

- The description of the STATUS operating status is also graphically shown on the control diagram of the unit
- **STATUS LED signals**

Tab. 17

LED Status Indicator STATUS - Color	LED Status Indicator STATUS - Indicator Type	Description of indicator lights
red	flashing	General unit error
green	on	Everything OK
	flashing	Shutdown phase initiated – cooling down – unit will shut down
blue	on	Unit is off
orange	on	Filter replacement indicator

- **WIFI LED signaling**

WIFI LED Status Indicator - Color:	Signalizae stavu LED WIFI - typ signalizace	Signal description
green	on	Control via the OK app
	slowly flashing	Weak Wi-Fi signal
	fast flashing	Internal error in the converter, unit, or server
blue	slowly flashing	Loading Wi-Fi network – everything OK
	fast flashing	Internet connection not working
cyan (light blue)	slowly flashing	Pairing mode active – the unit is ready to pair with the user
	fast flashing	Modbus communication not working

5.3.3. Hidden control functions

- The control behavior includes automatic processes that ensure optimal operation of the unit with an emphasis on the greatest possible service life and economy of operation. These processes are part of the factory setup and the manufacturer's know-how. The user cannot change them. These automatic processes may result in different behavior of the unit than the user assumes.
- These are mainly automatic processes:
 - o unit preheating control – activates only when necessary,
 - o activation of anti-freeze logic – measures to prevent the heat exchanger from freezing,
 - o minimum preheating runtime – protective function,
 - o cooling down after preheating is turned off – a protective function against overheating of the heat exchanger
 - o unit control using AQS sensors – automatic functionality based on ventilation needs

5.3.3.1. Temperature conditions for starting automatic bypass

- The temperature conditions for opening/closing the bypass are evaluated based on the temperatures (factory settings):
 - o Supply air temperature from the exterior: >19°C
 - o Indoor supply air temperature: >22°C
 - o Indoor temperature > outdoor temperature
 - o Hysteresis for closing/opening 2°C
- Automatic bypass functionality:
 - o When the above temperature conditions are met, the bypass opens/closes
 - o If the temperature conditions for the opening of the bypass are met, but the condition of the minimum difference in supply temperatures (hysteresis 2°C) is violated, the bypass is closed
 - o The opening of the bypass is always subject to the condition that the temperature in exterior must be lower than the temperature of interior, at least by 2°C - hysteresis



- **The temperature conditions for starting the automatic bypass can only be changed using the accessory Wall Wired Controller – Order Code – XCONT-TR-CENT-COMFORT**

6. Replacing filters



- Before starting any service work, it is necessary to turn off the power supply. The switch must be secured for the duration of the installation before being switched on again by an unauthorized person.
- The unit is equipped with a time countdown for clogging of filters for about 6 months (approx. 4400 hours). The time countdown records the real operation of the unit.
- The clogging of the filter depends on the environment in which the unit operates. Especially the dustiness of the surrounding air – the more dust particles are contained in the air, the sooner the filters become clogged. Therefore, always consider replacing the filters when signaling a clogging of filters.
- The filter replacement check indicator is indicated on the control panel by a red flashing LED called "filter" (position 5 on the controller).
- Before you start replacing the filter, make sure you have new filters:
 - o M5 filters XF-035/045-FILTER-M5
 - o F7 filters XF-035/045-FILTER-F7
 - o F9 filters XF-035/045-FILTER-F9
 - o G4 filters with carbon XF-035/045-FILTER-G4/AC

6.1. Filter removal

- Use the fabric straps to remove the plastic caps from the lid of the unit marked with the word FILTER.
- Pull out the filters, check or replace the filter with new ones

1 REMOVE THE FILTER CAPS USING THE FABRIC STRAPS

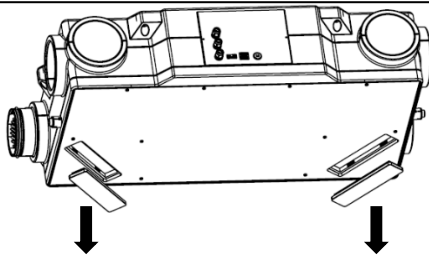

Pic. 68

2 EJECT FILTERS USING HANDLES

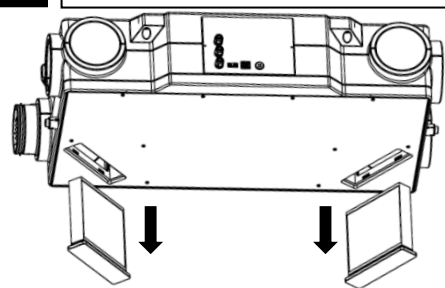

6.2. Filter Entry



- Pay attention to the correct orientation of the filter before inserting it into the unit with respect to airflow
- Insert the new filters into the unit.
- Align the filter handles so that they don't interfere with the plastic filter caps.
- Fit the filter caps into the lid of the unit so that they are at the same time as the lid of the unit.

1 INSERT NEW FILTERS

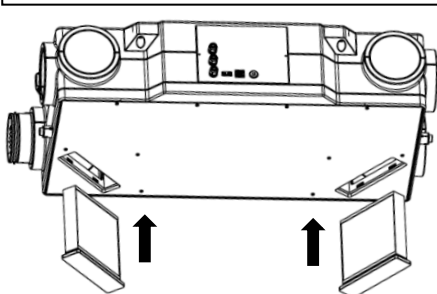

Pic. 69

2 REPLACE THE FILTER CAPS

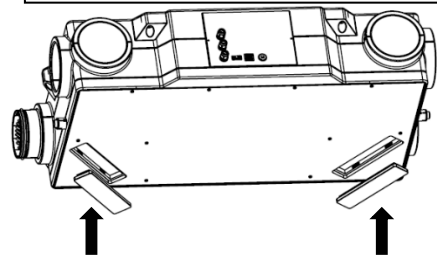

6.3. Filter Countdown Reset

- The filter is always reset only after the STATUS LED in orange control lights up
- Reset the filter in the normal operating state of the unit, as follows:



- o Turn off the unit with the power switch on the unit control cover
- o With added caution, remove the unit control cover according to clause 4.3.1



- Turn on the unit's power switch on the open enclosure – TAKE EXTRA CARE – the unit is powered at 230V when resetting the filter. Alternatively, contact an electrical technician with a valid license.



- Wait for the STATUS LED to turn orange
- On the control board, find the filter reset button (TL1 designation) – see the diagram in Chapter 4.3.2.
- Press the button for 6 sec until the STATUS LED turns green (normal operation). From this point on, the time for filter replacement begins to be counted again
- Turn off the unit with the main switch on the control cover
- Reassemble the control cover back onto the unit
- Turn on the unit with the power switch – the filter reset process is complete
- **If the filters are not properly replaced (cleaned), the functionality of the unit may be limited.**
- **Never operate the unit without air filters, as the recuperator may be damaged.**



Pic. 70



7. Regular maintenance and cleaning of Xflat units



- **Before any entry into the unit for maintenance and cleaning of the unit, the unit must be disconnected from the power supply**



- **Maintenance and cleaning must be performed at regular intervals, otherwise the functionality of the unit may be impaired.**

- **Cleaning and maintenance must not be carried out by children without supervision.**
- **Compressed air, steam, solvents, aggressive chemicals, harsh cleaning agents or sharp objects must not be used to clean the unit.**
- Maintain and clean the unit on a regular basis to ensure hygienic operation. In the case of regular replacement of filters (use the manufacturer's original filters) as indicated, a maintenance interval of a maximum of 2 years or at intervals determined by the relevant national regulations or customs must be observed.
- If the unit is not used for a long period of time, it is necessary to turn off the supply voltage to the unit.
- Service work that is beyond the scope of normal maintenance must only be carried out by an authorized service agent or manufacturer.



- Regular maintenance must include:
 - o Visual inspection of the unit shell — Chapter 7.1.1.,
 - o Visual inspection of the supply cable — Chapter 7.1.2.,
 - o Cleaning of the fan chamber and fans — Chapter 7.2.1.,
 - o Visual inspection and cleaning of the heat recovery heat exchanger — Chapter 7.2.2.,
 - o visual inspection — cleaning of external preheater, postheater if installed — Chapter 7.2.4.,
- To clean the unit from coarse dirt, dust, use a vacuum cleaner or a damp cloth with a common detergent (e.g.: soapy water)

7.1. Inspection – cleaning the exterior of the unit

7.1.1. Visual inspection of the unit shell

- The unit is cleanable over its entire surface.
- Visually inspect the outer shell of the unit for excessively dirty, damaged:
 - o if the smooth surfaces of the coat are dirty, wipe with a damp cloth with a common detergent (e.g.: soapy water),

7.1.2. Visual inspection of the supply cable

- Visually check that the power cord is not damaged, loose, torn out of the connection peripherals.
- **In case of damage, consult the issue with a person qualified for this activity with a valid authorization and knowledge of the relevant standards and directives.**



7.2. Inspection – cleaning the interior of the unit



- **Pay close attention to disassembling the unit's internal components. Improper disassembly may cause the unit to malfunction or limit its functions.**
- Unscrew the 10x M6x20 screw to attach the unit lid
- Use the textile straps to remove the filter caps
- Remove filters
- Remove the unit lid using the filter cap holes (position 9)

1

UNSCREW THE SCREWS

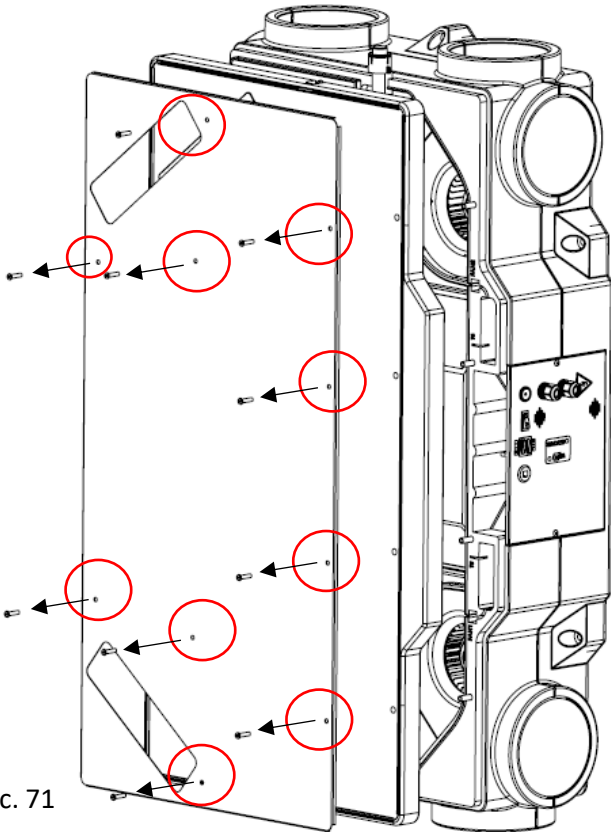

Pic. 71

2

FLIP UP THE LID OF THE UNIT TO ACCESS INTERNAL COMPONENTS

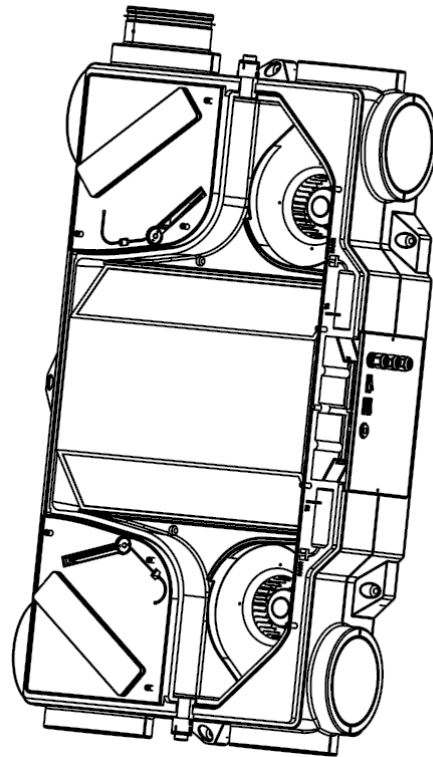

Pic. 72

- Be extra careful when removing the lid of the unit – the joints of the lid with the body of the unit are sealed in the area where the recuperator is located. When dismantled, the sealed joint may resist.



- **The subsequent subcategories of the instructions are consecutive activities that must be followed in the order listed.**

7.2.1. Cleaning the fan chamber and fans

- For better handling during cleaning, clean only one fan chamber with a fan at a time.
- Loosen the cables in the fan groove. Be extra careful not to damage the fitting when removing them. The cables are secured with glue to prevent spontaneous falling out.
- Carefully slide the fan beam assembly with the fan (position 11) out of the groove in the unit body.
- You can rotate the fan beam with the fan for better access by 180°.

1) Arrangement of fans in the unit

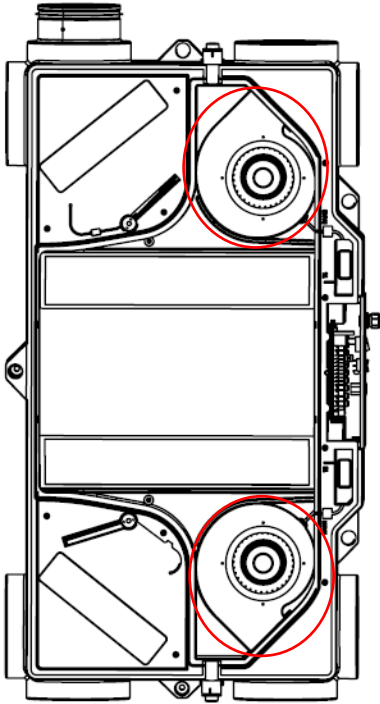

Pic. 73

2) Loosen the fan cables

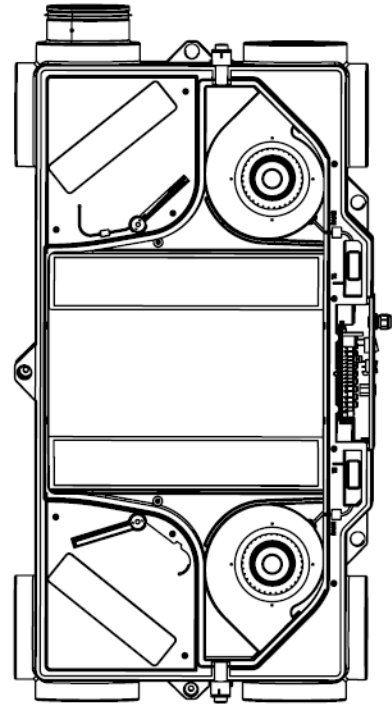

Pic. 74

3) Extension of fan subassemblies

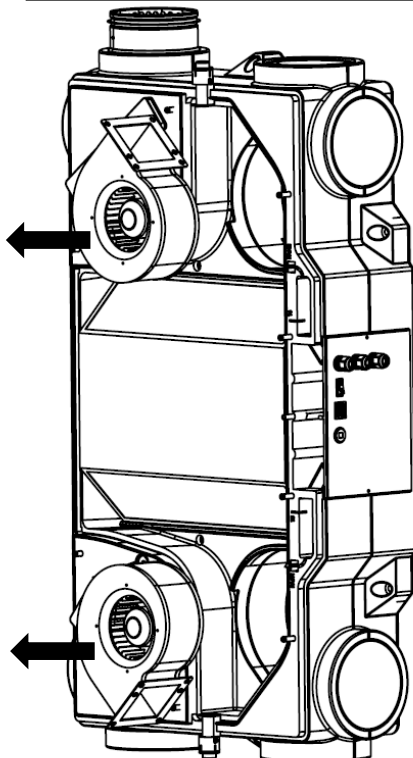

Pic. 75

- Vacuum up any dirt from the fan chamber or wipe with a damp cloth with a regular detergent (e.g. soapy water).
- With extra care, vacuum up the dust on the fan assembly, or wipe the assembly with a damp cloth with a common detergent (e.g.: soapy water)
- After cleaning the fans and fan chamber, perform the reversed process. Make sure that the cables are properly placed in the groove to prevent them from being crushed by the lid.

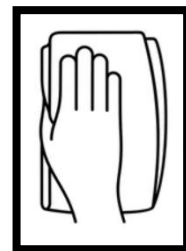
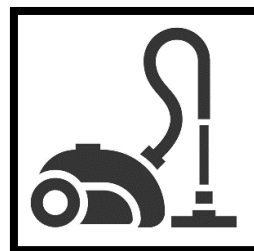

7.2.2. Visual inspection and cleaning of the heat recovery exchanger

- Then perform a visual inspection and cleaning of the heat recovery exchanger (position 12)
- Vacuum the exchanger with a vacuum cleaner or use a brush attachment for the vacuum cleaner. Always blow the exchanger with a vacuum cleaner at the end – to remove fine dust.

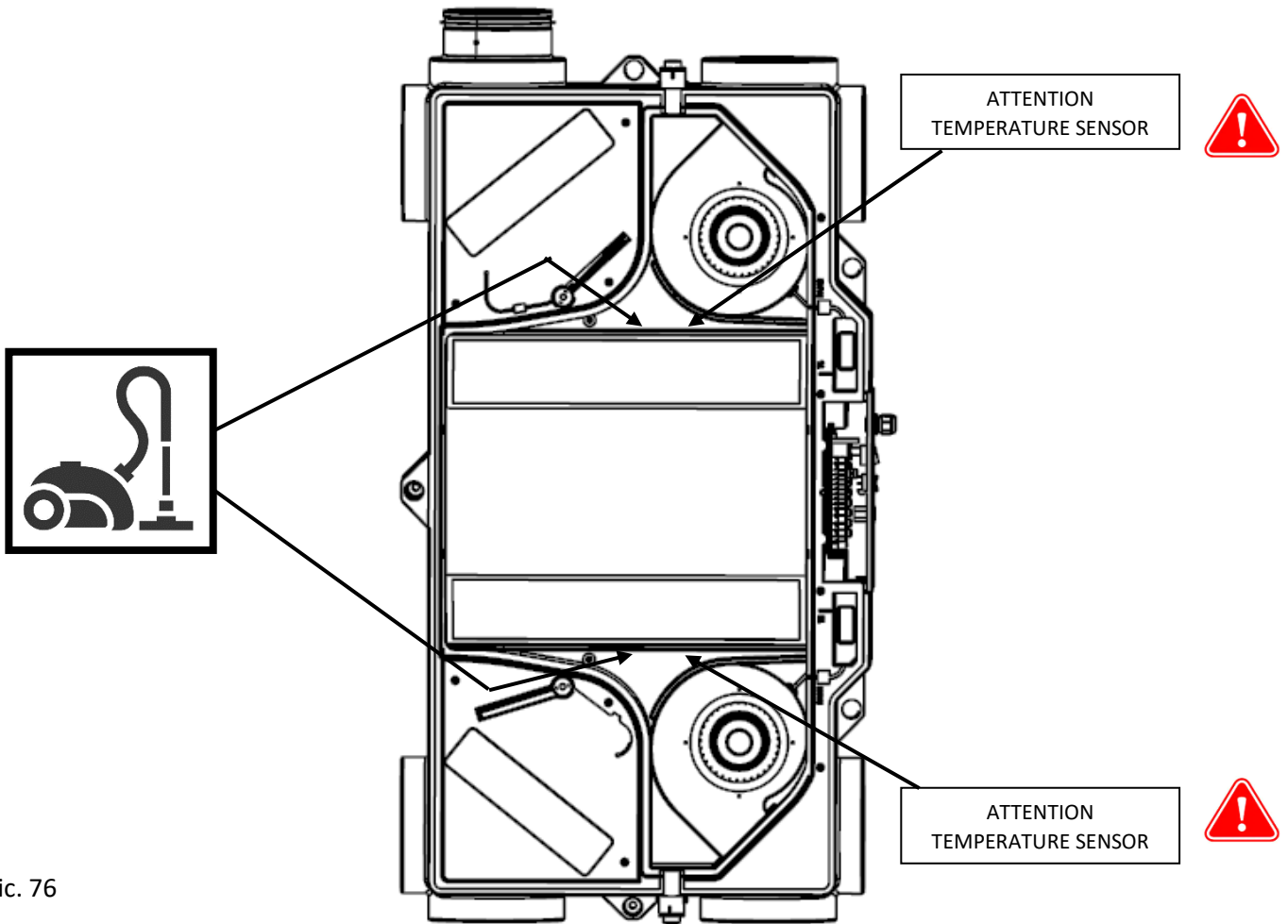

Pic. 76

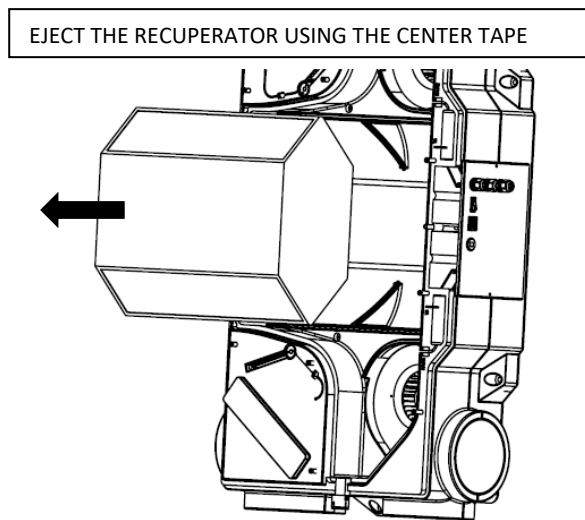

Pic. 77

- Treat the removed heat recovery exchanger with a disinfectant or antibacterial product that is suitable for cleaning and disinfecting aluminum and plastic. Allow the heat exchanger to dry thoroughly before inserting it into the unit!
- **Do not use any sharp tools or hard-bristled brushes to clean the exchanger. Avoid pressure washing and chemicals. There is a risk of permanent damage to the heat exchanger!**
- After cleaning, slide the heat exchanger back into the body of the unit



7.2.3. Visual inspection and cleaning of the integrated preheater – XF2-xxx-xxxxxxPxW-1A0

- To check and clean the integrated preheater, you must:
 - o Disconnect the duct from the ODA (supply duct from outside) socket in which the preheater is mounted
 - o Remove the filter at the ODA outlet
- Visually check the integrated preheater or vacuum with a vacuum cleaner both from the outside (duct connection) and from the inside (from the filter).
- **Never handle, remove or wipe the preheater with a damp cloth**



1) Disconnect the duct from the socket where the integrated preheater is located



2) Vacuum the dust from the preheater

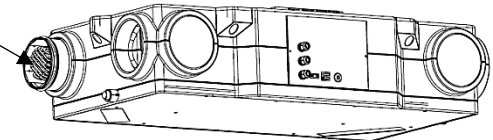
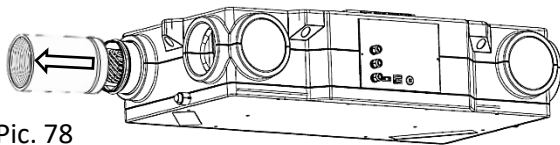

Pic. 78

3) Remove the filter caps, vacuum the filter and preheater

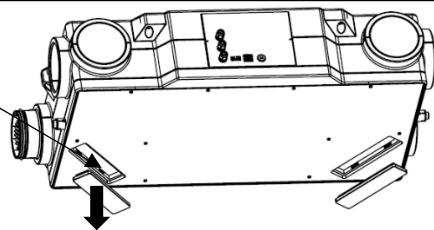

7.2.4. Reassembly – unit sealing XF2-035; XF2-045

- After the inspection and cleaning, reassemble the internal components into the unit according to the individual previous chapters using the reverse procedure.
 - o Replace and then tap the lid onto the body of the unit. Make sure that the lid of the unit is properly seated.
 - o Screw in the M6x20 screw 10x to secure, seal the lid of the unit.

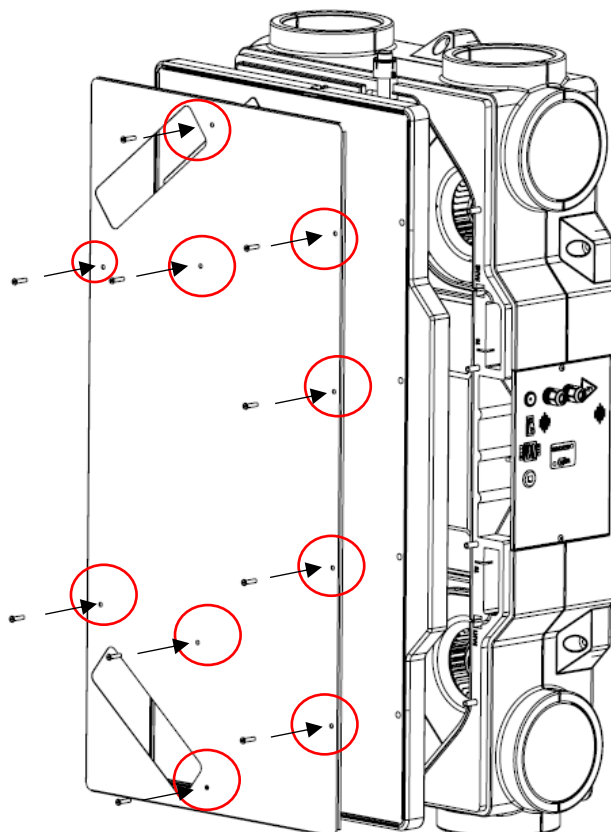

Pic. 79

7.2.5. Visual inspection – cleaning of external preheater, postheater – if installed

- External preheater and postheater are located in the air ducts that are connected to the unit
 - o Preheater – ODA air duct marking
 - o Postheater – SUP air duct marking



- **Perform maintenance according to the heater manufacturer's recommendations.**

- The general rules for cleaning duct heaters (postheater, preheater) are:

- o Clean the heater by vacuuming it with a vacuum cleaner.

- o **Never clean the duct heater with a damp cloth.**

- o **Check the power cord and its connection to the heater supply terminal block.**



- **Poor or neglected maintenance of the external duct heater is not the responsibility of the manufacturer of the unit.**

8. Service



- Warranty and out-of-warranty service may only be performed by a qualified professionally trained personnel and only with the use of original spare parts.
- The manufacturer reserves the right to make changes to the device, but these do not affect the essential properties of the device

8.1. Error messages – troubleshooting procedure

Tab. 19

Error number	Error message, malfunction	Possible cause of malfunction:	Troubleshooting	
1.	The unit won't start	The power cord is not plugged in.	- Check the electrical connection - Check if the safety switch is activated	
		The main power switch is in the 0 position.	- Set the switch to the "I" position	
2.	No or very little airflow even when the unit is set to maximum power	Clogged filter.	- Replace the filter as described in Chapter 5.	
		Clogged or blocked ductwork, unit outlet.	- Inspect the ductwork. Clean the unit as described in Chapter 6.	
3.	The unit started getting too loud	Clogged filter	- Replace the filter as described in Chapter 5.	
		Improper fan speed settings	Contact the service technician who set up the unit for you	
		Faulty motor bearing	- Contact the unit supplier	
4.	Internal electric preheating, the unit's external electric heating is not working (preheater, post-heater)	Clogged filter – no airflow	- Replace the filter as described in Chapter 5.	
		Clogged or blocked ductwork, unit outlet	- Inspect and clean the unit as described in Chapter 6.	
		Heat exchanger overheating protection activated	- Turn off the unit and the heater using the main power switch. Check the thermal protection—the thermostat with manual reset. If the problem persists, contact the unit supplier	
5.	The night cooling function cannot be turned on	Function startup conditions not met – outdoor temperature too low	- Wait for the outdoor temperature to rise. This function is active only during summer temperatures.	
6.		BOOST function active	- Wait for the BOOST mode to end - Turn off the BOOST function	
7.	The unit is not working. The STATUS LED is flashing red.	General malfunction	- Wait for a notification email with a description of the fault. Then contact a service technician	
8.	The connection between the app and the unit is not working—the Wi-Fi LED is flashing	Green light flashing slowly	Incorrectly entered Wi-Fi network, password, etc.	- Check your Wi-Fi connection and ensure the network password is correct;
9.			Weak Wi-Fi signal	- Check the Wi-Fi signal strength for the connection;
10.		Blue light flashing rapidly	Internet connection not working	- Check your internet connection;
11.		Green light flashing rapidly	Unidentified fault	- Restart the unit and the server; - Contact the manufacturer

8.2. Failure persists

- Restart the unit – turn off the unit on the controller, turn off the unit with the main switch. Wait about 30 sec and put the unit back into operation.
- In case of persistent unit failure, do not try to repair the unit yourself in any case.
- Turn off the unit with the main switch and disconnect it from the mains.
- Secure the unit against restart or tampering with by an unauthorized person.
- Contact your dealer.

9. Decommissioning, dismantling and recycling

- At the end of the machine's lifespan or at a time when repairing it would be uneconomical, carry out a complete disassembly of the machine.
- When disassembling the machine, it is necessary to observe the generally applicable safety regulations for the safe execution of all work.
- After the complete disassembly of the machine, the individual parts are disposed of in accordance with Directive 2012/19/EU and the applicable regulations of the country.
- Sort the metal parts by type of metal and hand them over to the appropriate secondary raw material collection organizations.
- Plastic parts that do not undergo natural decomposition are sorted and offered for sale to an organisation involved in the collection of these secondary raw materials.
- Parts of electrical equipment are handed over to the organization in charge of collecting electrical and electronic waste.



Hand over all unnecessary or obsolete products and their packaging to the appropriate take-back and recycling points. A professionally recycled product can be reused and contributes to environmental and health protection. Disposal must be carried out in accordance with Directive 2012/19/EU and the applicable regulations of the country. Do not dispose of the product in the municipal waste – use the designated take-back



10. Warranty

The unit warranty is valid according to legal regulations. The warranty is valid only if all assembly and maintenance instructions are followed. The warranty covers manufacturing defects, defects in materials or defects in the function of the device. We do not guarantee the suitability of the unit for special purposes, the determination of suitability is fully within the competence of the customer.

The warranty does not cover defects caused by:

- improper handling,
- during transport (damage caused by transport – financial compensation must be resolved with the carrier),
- failure to comply with the installation conditions,
- faulty electrical wiring or protection,
- improper operation,
- by interfering with the product,
- wear and tear in the normal way,
- due to a natural disaster.

When claiming the warranty, a protocol (located in the product documentation) must be submitted, which includes:

- information about the complainer/company,
- Date and number of the sales document,
- detail of the defect description,
- details of the socket lock,
- photo of the product nameplate, or serial number,
- photo from the product installation site,
- Measured values of the product: air temperature, voltage, current.

In the case of warranty and post-warranty service, contact your supplier or the installation company that performed the installation for you. The method of dealing with warranty repair is carried out at the place of installation of the unit or by agreement. The method of solving the warranty repair is entirely at the discretion of the company's service. The complaining party will receive a written statement on the outcome of the complaint – warranty repairs. In the event of an unjustified complaint, all costs associated with this shall be borne by the complaining party.

11. Conclusion

If you have any questions about the product, please feel free to contact us.

Contact address:

Xvent s.r.o.
Poděbradská 289, 53009
Pardubice-Trnová
Czech Republic
www.xvent.cz

