

QUICK INSTRUCTIONS FOR USE AND

Xflat heat recovery units – 200; COMFORT, COMFORT+ control

Quick Instructions guide you through quick installation of the product, but in no way replace the complete full manual. The complete operating instructions are available in the documents on our website www.xvent.cz or can be downloaded via QR code.



Check that there are no electrical or other wiring (e.g.: gas, water, etc.) at the installation point of the unit on the wall or ceiling indoors that could be disturbed during installation. Make sure that the mains power supply to which you want to connect the unit meets the unit's power requirements (rating plate).



Make sure that the installation of the unit does not compromise the statics of the building and meets all legislative safety. Before starting the installation, check the possibility of connecting to the sewer system for draining condensate from the unit.

1) Using the unit

The Xflat-200 unit is an air-conditioning device using ventilation technology with heat recovery (counterflow heat recovery exchanger) and humidity (enthalpy exchanger) with the possibility of automatic control using AQS air quality sensors (accessory) or permanent ventilation – manual mode. The unit has an intermittent ventilation mode - BOOST with use, for example: in the toilet, in the bathroom. The unit control also allows remote control ON/OFF using an external EXT1 contact, control via a superior BMS system (Modbus RTU protocol) or even control via a web application (Wifi module). The Xflat unit also allows the function of fan distribution for use, for example: in buildings with a furnace - fireplaces. The air output, BOOST mode run time and fan distribution are separately adjustable in the customer menu. The design of the unit allows, after removing the lid, to rotate any neck by 90° - the Multiflex system.

The unit can be used in areas with a maximum requirement for a nominal flow rate of approx. 200 m³/h (depending on the type) at a maximum disposition pressure of 200Pa.

The unit is only intended for horizontal or vertical wall and ceiling installation to ensure fresh air supply and exhaust air extraction. The unit allows switching between the right (factory setting) and left version using a switch on the control cover. The unit is equipped with constant flow technology (regardless of external pressure loss). The unit has swivel corners. The unit is designed for indoor covered and dry areas with a room temperature from +5 °C to +30 °C and a maximum relative humidity of 70%.



The supply temperature of the fresh air from the outside can be in the range from -20 °C to +40 °C (applies to the preheated version). If the supply air temperature is below -20 °C, the unit may automatically shut down to protect it from possible damage.

2) Technical parameters

Type Xflat		Xflat 200 - Comfort		Xflat 200 - Comfort+	
		XF1-020-ECS0HRXAC-0A0	XF1-020-ECS0ERXAC-0A0	XF1-020-ECS0HRXAC-1A0	XF1-020-ECS0ERXAC-1A0
Type of recovery exchanger		HRV - temperature	ERV - Temperature/Humidity	HRV - temperature	ERV - Temperature/Humidity
Bypass type		electronic	electronic	mechanical	mechanical
Nominal airflow*	m ³ /h	155 / 207			
Acoustic level**	dB(A)	31,4 / 35,1			
Weight***	kg	16		16,5	
Power supply	V / Hz	1 ~ 230 / 50-60			
Nominal input****	W	104 / 172 (181)			
Nominal current****	A	0,74 / 1,22 (1,29)			
Thermal efficiency	Heat	89,3 / 88	80,5 / 78	89,3 / 88	80,5 / 78
	Humidity	-	43 / 40	-	43 / 40
Electric safety		IP 20			
Energy class (ERP)*****		Cold climate A+, mid climate A, warm climate E / Cold climate A+, mid climate A+, warm climate E			

* Nominal airflow for 150/200 m³/h (power input, current) at external pressure drop of 200Pa,

** Sound pressure level in free space at a distance of 3m (Q2) - for an air output of 150/200 m³/h

*** Unit weight without packaging

**** Power consumption, current - for air flow 150/200 m³/h (max. possible power consumption, current)

***** Heat recovery efficiency stated at 70% of nominal flow according to EN 308 - for air output 150/200 m³/h

***** Energy efficiency class (ERP) - for air flow rate 150/200m³/h



Prohibited use of Xflat-200 drive

- The unit must not be used to extract burning, glowing substances, flammable or explosive gases, aggressive media, liquids.
- The unit must not be installed just below the electric. socket, ele. a box, flammable materials, for environments with an increased occurrence or risk of explosion, flammable substances, with increased dustiness and for environments with higher humidity, e.g.: bathrooms, swimming pools, saunas.

- Neither the manufacturer nor the supplier is liable for damage caused by improper use of the units. The risk is borne by the user.

3) Installing the Xflat-200 unit

- Minimal installation distances

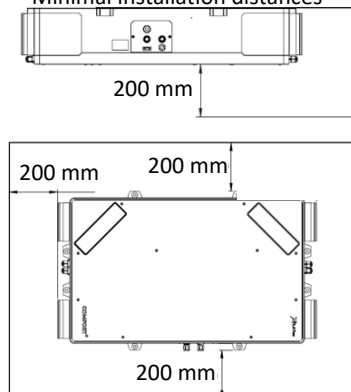

Installation Positions – VERTICAL ON

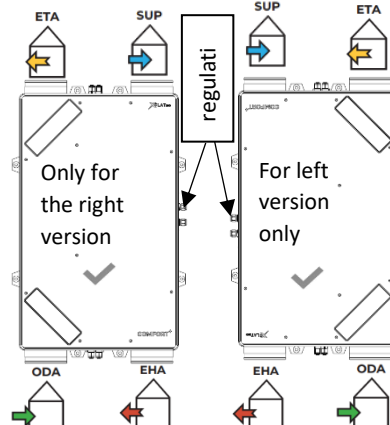

HORIZONTAL TO THE

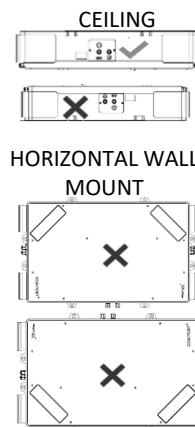

The heat recovery unit must be installed and put into operation in accordance with the general and locally applicable safety regulations, by a person with appropriate education, experience and knowledge of the relevant regulations, standards and possible risks and possible hazards, or by an appropriately trained service technician. **Failure to follow the installation procedure may result in damage to the unit, malfunction, possible harm to the user's health and property.**

- How to install Xflat drives

a) Remove the unit from the

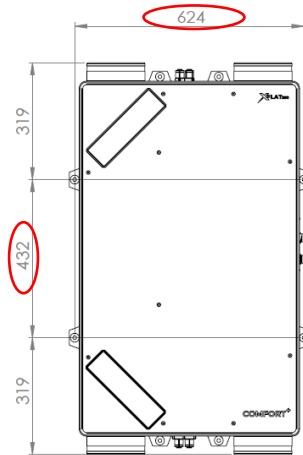
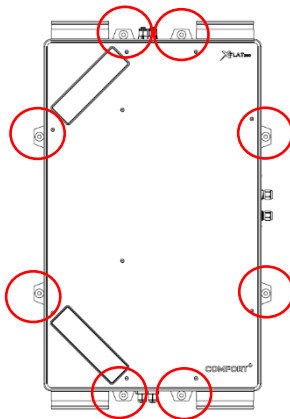
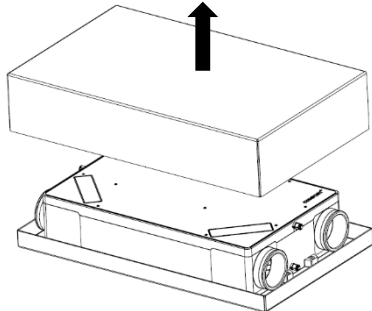

b) Choose the installation position with respect to the location of the condensate outlet, measure the anchoring holes according to the dimensions on the unit, drill and anchor the unit to the level using suitable screws. Do not tilt the unit into a slope.

Vertical wall mount – right version
– switch position "R"
Factory settings

Vertical Wall Mounted –
Left Version – switch
position "L"

To the ceiling – right version – switch
position "R" – green nut – Factory setting

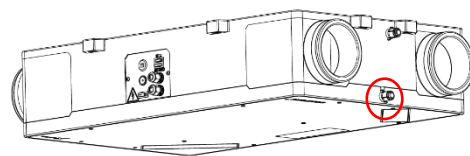
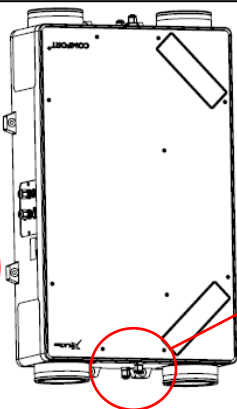
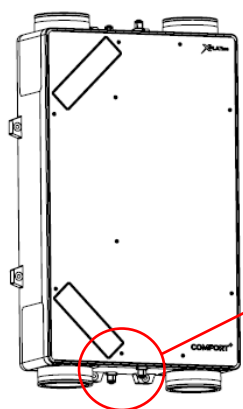

Ceiling-mounted – left version – switch
position "L" – blue nut

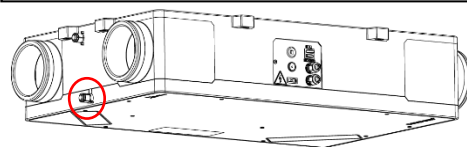

c) cut off the edge of the condensation outlet and remove the burrs

(d) Use the hose and straps to create a siphon

(e) Choose the correct position
of the siphon for connection to

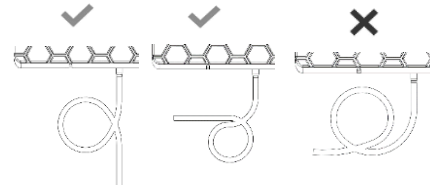
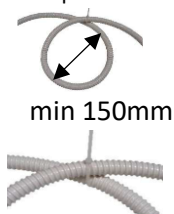
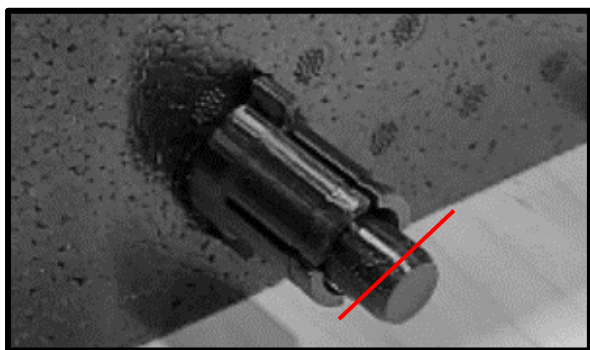

f) Water the siphon, connect the
hose to the drain neck of the unit
and secure it with a binding strap

(g) Connect the
siphon to the sewer
system

Socket designation – right
version - switch position "R"

Nozzle designation – left
version – switch position "L"

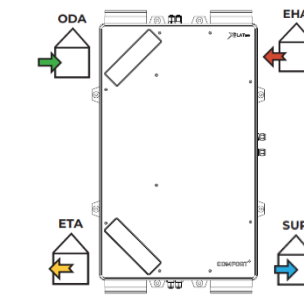
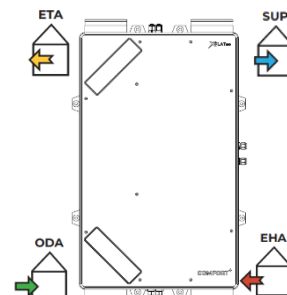
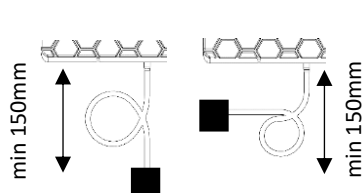
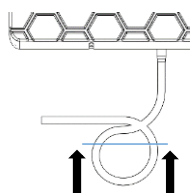

ATTENTION: if the air conditioning is used in a ventilated building for cooling in summer, it is necessary to connect the second condensate outlet – see the complete instructions



- Before starting the unit for the first time or after a longer shutdown, check the water level of the siphon. If you are making a bend on the hose, make sure that the bend radius is correct to avoid "breakage" of the hose. To extend the siphon hose, always choose a hose – a pipe of the same or larger diameter. Always choose a hose-pipe connector with the smallest possible reduction in the inner diameter.

- All pipe joints that are connected to the unit must be sufficiently sealed to prevent unwanted leaks and thus consequent problems, e.g.: condensation-connected pipes must be of the same diameter as the unit's connection necks. If the duct used is smaller in diameter, it can affect the air output of the unit and thus reduce the life of the fans

4) Installing the Xflat-200 driver

- The unit controller comes standard with a unit with a 10m cable, on one side the cable is connected to the controller and on the free end the cable has an RJ connector for easy connection to the unit.

A) Installation of the controller on the wall – standard length of communication cable 10m

- Open the controller box – the front of the box is connected to the back by magnets, use reasonable force to open it to avoid damaging the controller.

- Do not disconnect the cable from the controller

- Screw the rear metal part of the controller onto the wiring box with adequate fasteners

- **Secure the cable route between the unit and the controller so that it is stable and cannot be accidentally damaged, damaged or even interfered with from another source.**

B) Connecting the unit and controller

- Insert the free end of the communication cable with the RJ connector (male) into the RJ connector (female) on the cover plate of the unit regulation

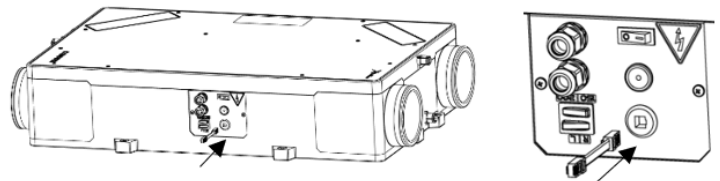

(a) Open the controller box

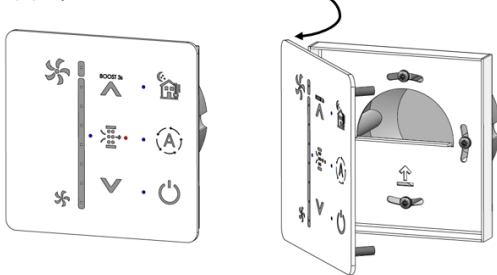

(b) Controller dimensions

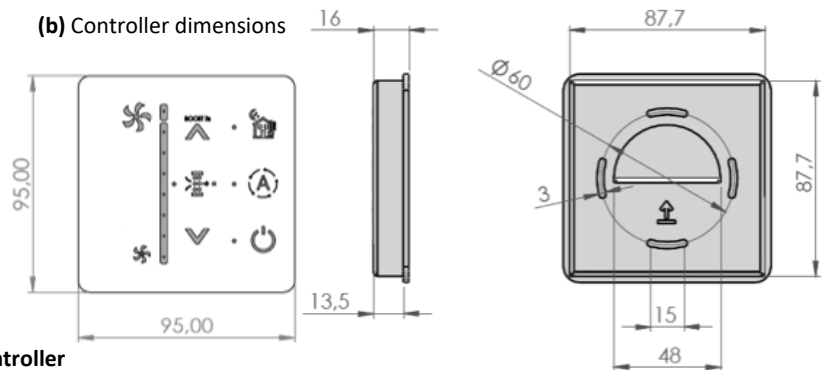

c) Disconnecting the communication cable from the controller

- If necessary, the connected end of the communication cable can be disconnected to the controller, e.g. when the cable is pulled through the construction cavity (protector).

- Spring-loaded terminals with manual wire locking are used for wire connection. A solid conductor (wire) must be installed in the terminals in the cross-sectional range from 0.2 to 0.75 mm².

- Before inserting the wire into the terminals, first press the lock on the terminal with a flathead screwdriver of an appropriate size (max width 1.5 mm). Then insert the wire, release the lock and check that the wire is properly locked by pulling lightly from the terminal. If you need to remove the wire from the terminal, the procedure is the same.

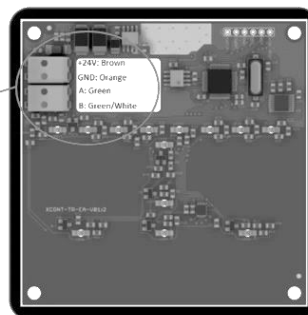
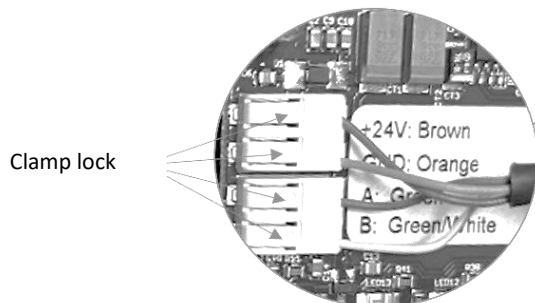

Use reasonable force to release the terminal lock to prevent damage to the terminal or PCB controller. The insulation on the individual conductors must be shaved in the range of 7 - 9 mm.

d) Installing the controller on the wall - external

- To install an external communication cable (the length of the standard cable is insufficient), secure the cable:

o 8-core UTP cable with RJ45 8/8 terminals
Preparing the communication cable towards the controller

Preparing the communication cable towards the unit – RJ

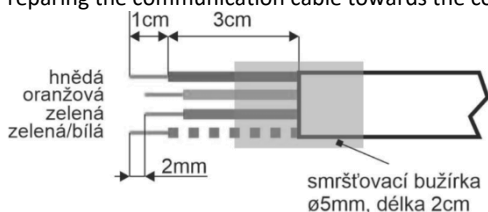

oranžová/bílá
oranžová
zelená/bílá
modrá
modrá/bílá
zelená
hnědá/bílá
hnědá

4) Electrical installation – connection to the mains

 - Before beginning any installation work, make sure that the conduit box or mains power receptacle to be used to connect the unit is fitted with a ground (green-yellow) wire or contact (pin)

- If you use the mains plug to connect the unit, it must remain accessible at all times so that the unit can be safely disconnected from the mains in the event of danger.

- The relevant current circuit must be protected in the power distribution system with a maximum of 16 A.

- The electrical connection of the unit to the network can only be carried out by persons qualified for this activity with a valid authorization and knowledge of the relevant standards and directives in the given country.

- This unit belongs to the product group with a type Y connection. If the power cord is damaged, it must be replaced by the manufacturer, its service centre or a similarly qualified person in order to prevent a hazardous situation from occurring

- The supply voltage to the unit 1~230V/50-60Hz must not be modified in any way, otherwise there is a risk of damage to the unit's electrical elements.

- Connecting the Xflat-200 unit to the mains

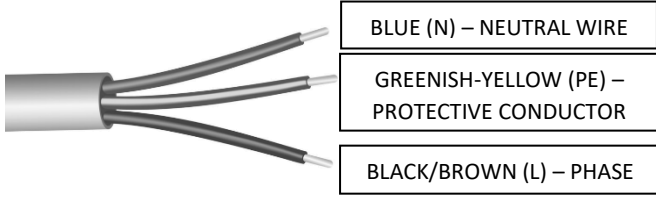

- Connecting the unit to the wiring box

- The supply cable is prepared by the manufacturer for connection to the wiring box.
- To connect the supply cable to the mains, use adequate interconnecting elements (e.g.: terminal block, spring terminals, etc...)

- Connecting the unit to a power outlet

- Supply cable can be fitted with a plug with a protective conductor (pin) – not included in delivery

⚡ The installation of the supply cable in the electrical installation box or the installation of the plug on the supply cable and subsequent connection to the mains must be carried out by a qualified person who has a valid authorization for this activity and

5) Regulation – electrical accessories for the Xflat - 200 unit

- For the correct operation of the unit (in manual mode), there is no need to connect anything else to it. It is therefore ready for immediate use after installation on the wall. To operate in automatic mode, you must connect a CO2 (NL-ECO-CO2) or RH (NL-ECO-RH) air quality sensor accessory

⚡ - Electrical accessory connection

Always turn off the unit on the controller and the main switch before connecting electrical accessories

- Connect the electrical accessories in the control box. Use the membrane multi penetration to connect accessories. To access the control box, proceed as follows:

a) loosen the bushing nuts

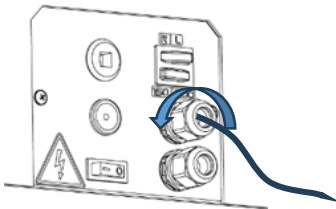

(b) Unscrew the locking screws of the control cover – remove the cover

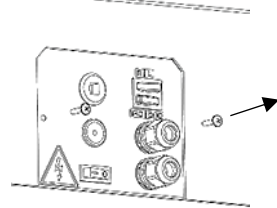

(c) Feed the cable through the membrane multi penetration of the

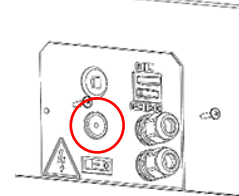

e) Plug the cable into the appropriate terminals in the motherboard according to the diagram

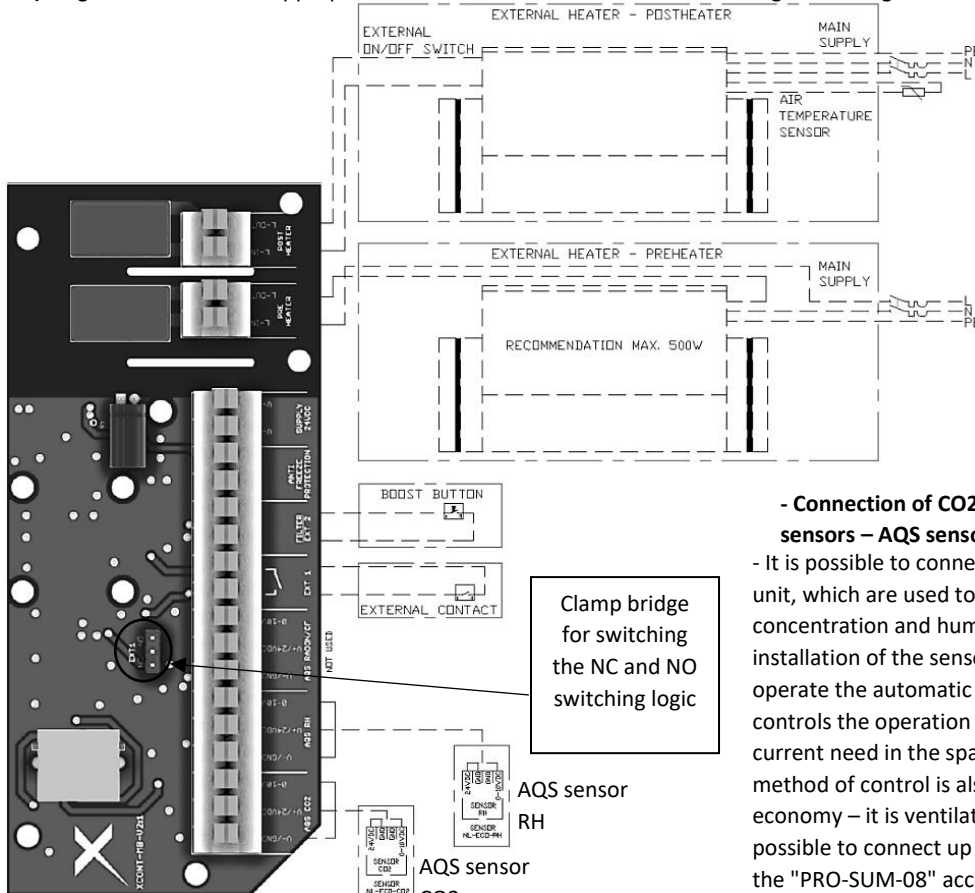

- Spring-cage terminals with manual conductor locking are used to connect the individual components. A licna type conductor (stranded wire with a ferrule) and a solid conductor (wire) can be installed in the clamps in the cross-section range from 0.5 to 1.5 mm², shaving length 10 mm. Before inserting the wire into the terminals, first press the orange locking button. Then insert the wire, release the lock and check that the wire is properly locked by pulling lightly from the terminal. If you need to remove the wire from the terminal, the procedure is the same. Choose the optimal conductor cross-section according to the length of the conductor route

- Connection of CO2 (NL-ECO-CO2) and RH (NL-ECO-RH) sensors – AQS sensors (AQS CO2; AQS RH)

- It is possible to connect 2x AQS sensors (1xCO2 and 1xRH) to the unit, which are used to measure the content of CO2 concentration and humidity - RH in the air at the place of installation of the sensors. Thanks to the sensors, it is possible to operate the automatic mode of the unit, which automatically controls the operation and air output of the unit according to the current need in the space where the sensors are installed. This method of control is also the most efficient in terms of operating economy – it is ventilated only as needed. If necessary, it is possible to connect up to 8 sensors of one type to the unit using the "PRO-SUM-08" accessory (1pc "PRO-SUM-08" = 8pcs CO2; 1pc "PRO-SUM-08" = 8pcs RH).

- Technical parameters of AQS sensors for connection to the unit

- Sensor power supply 24VDC
- Analog output 0- 10VDC
- Max sensor power 5W
- Analog input sensor resistance 100kΩ

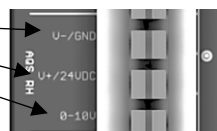

- Functionality of the unit for connecting AQS sensors

- The unit responds with continuous control to the ventilation demand caused by the sensor in real time
- switching concentration of the CO2 sensor is 800ppm, RH 65%
- Tripping concentration of the CO2 sensor is 700PPM, RH 60%

- External contact connection – EXT 1

- The unit regulation allows the connection of an external contact for remote switching on and off of the unit (remote ON/OFF control).
- The external contact is designed as potential-free, it can be switched e.g.: magnetic contact, remote switch, time relay

- Technical parameters of external contact EXT 1

- o Switching voltage 24 VDC / 5mA
- o The contact can change the switching logic by switching the bridging bridge to NC or NO (factory setting) switching logic.

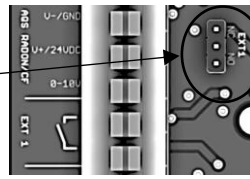

- Functionality of the unit when controlled by an external contact EXT 2

- External contact turns the unit on and off (the same functionality as the ON/OFF button on the controller) with logical termination or switching on of all running processes at the time of switching off, on.

- If the unit is turned on/off by an external contact, it may be turned off/on by the controller on the unit.

- External contact connection – EXT 2 - BOOST

- The unit control allows the connection of an external button (flap switch with automatic flap return – e.g.: bell button with return spring) to start the burst ventilation mode for a set period of time – BOOST (hereinafter referred to as BOOST) for use e.g.: in the bathroom

- Technical parameters of external contact EXT 2 - BOOST

- o Switching voltage 24 VDC / 5mA
- o External contact is designed to be potential-free
- o The factory setting is max. air output, running time 1min.



- BOOST mode functionality – EXT 2

- An external on/off switch activates the BOOST mode to the set air output and run time. When the BOOST run time ends, the unit returns to the previous mode.
- To end the BOOST mode prematurely, hold the button for approx. 2sec. The BOOST mode can also be called directly from the controller.

- Switching the nominal air output

- The unit control allows switching the nominal output of the unit at the EXT3 terminals in logic: clamp fitted with 150m3/h; (switch position "150"); 200m3/h (switch position "200" - factory setting)

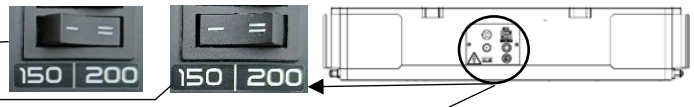

- Switching between right/left version of the unit

- The unit regulation allows switching between right and left versions by means of a switch in the logic: right version – position "R" - factory setting; left version – position "L"



- Connection of the unit to a superior BMS system and to control via the WifiModule web application

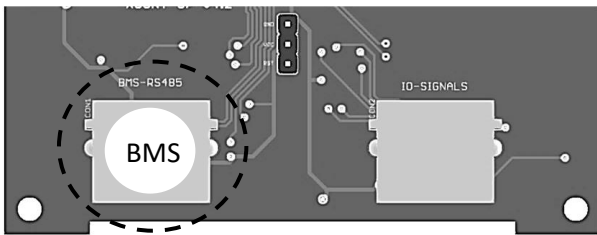

- The unit can be connected to a higher-level BMS system using the Modbus RTU communication protocol and to control via a web application using the "WifiModule" accessory.

- Connect the communication cable by the superior BMS system or WifiModule accessories to the BMS-RS485 connector in the controller. Provide the UTP communication cable with RS485 8/8 connectors. Connector wiring type – DIRECT.

- A description of the communication protocol is given in a separate document "D-502-xxx-Vxxx-xxx-MN-CENTRAL-MODBUS".

- Connection of an external electric preheater – PREHEATER

- It is possible to connect an external electric heater to the unit – preheater (see accessories "EK-PH-160-06-1f") with a maximum power of 1500W, voltage 1x230V.
- Recommended heater power min 400W to 600W
- The unit switches only the supply phase – potential (L-IN) to the heater (L-OUT).
- The preheating switching logic is subordinated to the temperature on the anti-frost sensor, which is located in the recuperative heat exchanger in the exhaust air branch.
 - o Switching temperature – 3°C (temperature on the frost sensor).
 - o Expansion temperature - 5°C – end of frost protection –
- If the preheating is not enough, other logics are triggered for preheating.

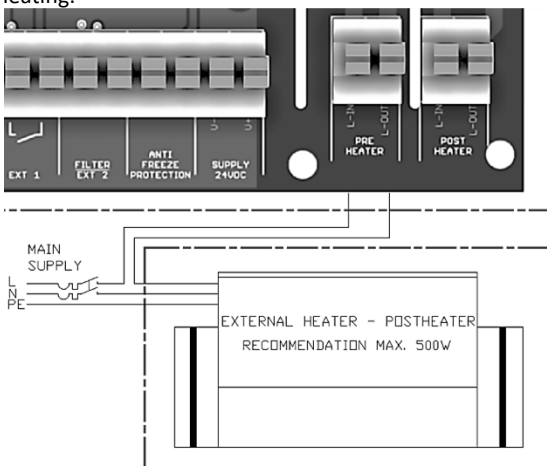

- Connection of an external electric heater – POSTHEATER

- It is possible to connect an external electric heater (see accessories "EK-AH-160-0,6-1f") with a maximum power of 1500W, voltage 1x230V.
- The unit switches only the supply phase – potential (L-IN) to the heater (L-OUT) in logic:
 - o If the unit is ventilating, the phase is switched – potential switched
 - o When the unit is stationary, the phase is switched – potential is open – the afterheating function is active – 3min
- The unit control cannot detect the presence / absence of additional heating, so the afterheating function is active all the time.

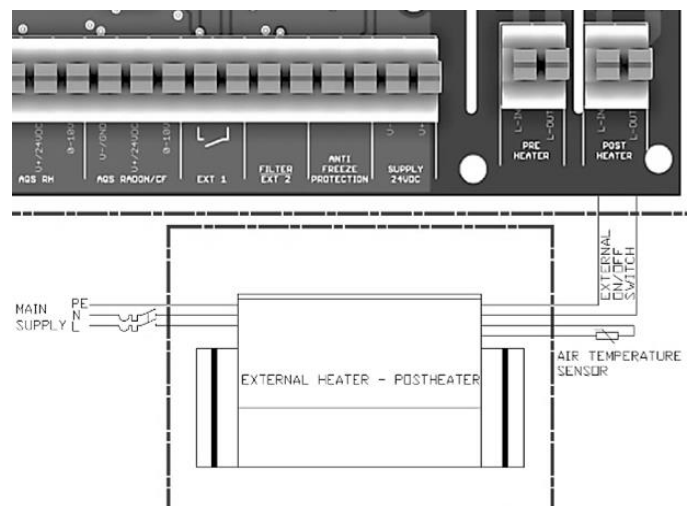



- Install the heater according to the heater manufacturer's instructions. The unit manufacturer is not liable for poor installation of preheating or reheating or for damage to property or health.
- The supply cabling for powering the heater must be solved by a separate supply including the switching phase controlled by the unit. in no case must the heater be powered from the unit.

- Block diagram of the Xflat – 200 unit; COMFORT and COMFORT+ control

