

OPERATING AND ASSEMBLY INSTRUCTIONS
CENTRAL RECUPERATION UNITS
XFLAT 200
COMFORT, COMFORT+ regulation

TABLE OF CONTENTS

1. General information	5
1.1. Introduction	5
1.2. Warnings and Symbols	5
1.3. Using the Xflat 200 Unit	6
1.3.1. Unit Designation	6
1.3.2. Prohibited environment, use, assembly of the Xflat 200 unit:	6
1.4. Transport, Delivery Control, and Storage	7
1.4.1. Transport	7
1.4.2. Delivery Inspection	7
1.4.3. Storage	7
1.5. Xflat 200 Unit Package Contents	7
1.6. Before Starting the Assembly	7
2. Technical parametrs	8
2.1. Basic part unit	8
2.1.1. Unit Body – Fitting (position 1)	9
2.1.2. Unit cover (position 2)	9
2.1.3. Connection throats - Swivel Corners (position 3.)	9
2.1.4. Supply cable (position 4)	9
2.1.5. Production label (position 5)	9
2.1.6. RJ connector (position 6)	9
2.1.7. Tapping Screw $\varnothing 4.2 \times 13$ (position 7)	9
2.1.8. Bolt M6x25 (position 8)	9
2.1.9. Filter caps (position 9)	9
2.1.10. Filters (position 10)	9
2.1.11. Fans (position 11)	9
2.1.12. Recuperator (position 12)	9
2.1.13. Regulation Box (position 13)	9
2.1.14. Condensate outlet (position 14)	9
2.1.15. Main switch (position 15)	9
2.1.16. Screw grommet (position 16)	9
2.1.17. Membrane multi-grommet (position 17)	9
2.1.18. Right/left unit version switch	9
2.1.19. Unit nominal air capacity switch	9
2.2. Main dimensions of the Xflat 200 unit	10
2.3. Technical parameters of Xflat 200 units	11
2.3.1. Basic Technical Parameters	11
2.3.2. Xflat - 200 Acoustic Data	12
2.3.3. Heat and Moisture Recovery Efficiency - Xflat - 200	13
- Nominal flow 150 m ³ /h	13
3. Unit Assembly	15
3.1. General information, recommendations, and safety when assembling the Xflat 200 unit	15
3.1.1. Electrical safety before the unit assembly	15
3.1.2. Unpacking the Xflat 200 Unit	15
3.1.3. Unit Location	16

3.1.3.1.	Location and operation of the unit in the area with a furnace (fire place)	16
3.1.3.2.	Unit Location and Operation in the Area with an Air Conditioning Unit	16
3.1.4.	Minimum Assembly Distances	16
3.1.5.	Permitted installation positions of the Xflat 200 unit according to the switch setting (position 18) of the unit version right/left ..	17
3.1.5.1.	The right version of the unit – switch switched to position “R” – factory setting	17
3.1.5.2.	Left version of the unit – switch switched to the "L" position	17
3.1.6.	Prohibited assembly positions of the Xflat 200 unit	17
3.2.	Xflat 200 Unit Assembly	18
3.2.1.	Mounting equipment required to assemble the Xflat 200 - general requirements	18
3.2.2.	Positioning, assembly of the unit on the wall or ceiling	18
3.2.3.	Mounting the unit controller	19
3.2.3.1.	Basic controller dimensions	19
3.2.3.2.	Assembly of the controller on the wall - standard length of the communication cable 10 m	19
3.2.3.3.	Connecting the unit and the controller	20
3.2.3.4.	Disconnecting the communication cable from the controller	20
3.2.3.5.	Assembling the controller on the wall - external communication cable	20
3.2.4.	Connection of condensate drain - siphon	22
3.2.4.1.	Condensate drains right-hand version of the unit – switch in position “R” – factory setting	22
3.2.4.2.	Condensate drain left-hand version of the unit - switch in position "L"	22
3.2.4.3.	Connecting the condensate drain to the siphon	22
3.2.5.	Connecting the air duct to the unit	24
3.3.	Electrical Assembly – Connection to the Mains	25
3.3.1.	General Information – Safety	25
3.3.2.	Connection to Mains	26
3.3.2.1.	Connection of the Unit to the Wiring Box	26
3.3.2.2.	Connecting the Unit to the Electrical Outlet	26
3.3.2.3.	Recommendations for protecting the Xflat 200 unit	26
3.3.3.	Display of Electrical Parameters	26
4.	Regulation	27
4.1.	General Information – Safety	27
4.2.	Setting up the unit - connecting accessories	27
4.2.1.	Regulation Approach	27
4.2.2.	Settings - switching the right left unit - EXT4	28
4.2.3.	Settings – switching the nominal output of the unit	28
4.2.4.	Connecting Electrical Accessories	29
4.2.4.1.	Connection of the CO2 (NL-ECO-CO2) and RH (NL-ECO-RH) sensors - AQS sensors (AQS CO2; AQS RH)	29
4.2.4.2.	Connecting multiple AQS sensors	30
4.2.4.3.	Unit functionality after connection of the AQS sensors	30
4.2.4.4.	External Contact Connection – (EXT 1)	30
4.2.4.4.1.	Technical Parameters of External Contact EXT1	30
4.2.4.4.2.	Functionality of the Unit when Controlled by External Contact EXT1	31
4.2.4.5.	External Contact Connection – BOOST (EXT2/FILTER)	31
4.2.4.5.1.	Technical Parameters of External Contact - BOOST	31
4.2.4.5.2.	BOOST regime functionality	31
4.2.4.6.	Connecting the unit to a higher-level BMS or web application using the Modbus RTU protocol	31
4.2.4.7.	Connecting the external electric preheater - (PREHEATER)	32

4.2.4.8.	Connecting an external electric postheater - (POSTHEATER)	33
4.3.	Block diagram of the Xflat 200 unit – Regulation COMFORT, COMFORT+	35
5.	Commissioning	36
5.1.	Prior to the first start, check:	36
5.2.	Activation – Basic Unit Commissioning.....	36
5.3.	Controller Operating Regimes	37
5.3.1.	Sleep Regime – Regular Operating Regime.....	37
5.3.2.	Control Regime – 1 click.....	37
5.3.3.	Unit Setting Regime – 2 clicks.....	37
5.4.	Unit Control Method.....	37
5.4.1.	Control Panel – Controller	37
5.4.2.	Description of the functions of the push-buttons and regulation	38
5.4.3.	Description of the ventilation power setting range.....	39
5.4.4.	Ventilation Output Settings	39
5.4.5.	Display of the LED Indicated Statuses on the Controller	39
5.4.6.	Hidden Regulation Functions	40
5.4.7.	Automatic Unit Control using AQS Sensors	40
5.5.	Customer Menu	41
5.5.1.	Service Menu Access	41
5.5.2.	Setting the air output for the BOOST regime - 1st screen	41
5.5.3.	BOOST regime run time setting - 2nd screen	42
5.5.4.	Fan distribution setting - 3rd screen	42
5.5.5.	Setting temperature conditions for mechanical automatic bypass (SET1/SET2) - 4th screen	43
6.	Replacing Filters	44
6.1.	Filter Removal.....	44
6.2.	Filter Inserting.....	45
6.3.	Reset filter countdown	45
7.	Regular Maintenance and Cleaning of Xflat Units	46
7.1.	Inspection - Cleaning the Unit’s Exterior.....	46
7.1.1.	Visual Inspection of the Unit Enclosure	46
7.1.2.	Visual Inspection of the Supply Cable	46
7.2.	Inspection - Cleaning of the unit interior	47
7.2.1.	Cleaning the Fan Chamber and Fans	48
7.2.2.	Visual Inspection and Cleaning of the Heat Recovery Exchanger.....	49
7.2.3.	Reassembly - sealing of the Xflat 200 unit	50
7.2.4.	Visual inspection - cleaning of the external preheater, reheater - if installed	50
8.	Servicing	50
8.1.	Error Messages – Troubleshooting Procedure	51
8.2.	Malfunction Persists	52
9.	Final Decommissioning, Dismantling, and Disposal.....	52
10.	Warranty	52
11.	In Conclusion	53

1. General information

1.1. Introduction

- This document “Operating and Assembly Instructions” is designed for the Xflat central heat recovery units (hereinafter the unit only). At the same time, it is superior to the brief manual placed directly on the unit, so-called “Quick Manual”.



- **Assembly and connection of the unit may only be performed by a trained person with the appropriate authorisation for the connection of electrical equipment who has the appropriate tools and resources at his disposal. All the instructions and recommendations provided in this manual must be observed during assembly**

- Detailed familiarisation with this document is important for the unit's correct and safe assembly and functioning. Failure to comply with the conditions set out in this document may lead to the unit's malfunction.
- Please, retain this unit assembly manual for future reference after reading it thoroughly.
- It is forbidden to interfere in any way with the unit's internal connection other than as specified in this manual. Due to the continuous development of our products, we reserve the right to change this manual without prior notice.
- Children and persons with reduced physical, sensory, or mental capabilities, or lack of experience and knowledge, may use the unit only under supervision or if they were instructed on the unit's use in a safe way and understand potential risks.
- Children may not play with the appliance.

1.2. Warnings and Symbols

- The following names and symbols shall be used in the operating instructions, on the packaging, and on the product for particularly important information:



Warning, pay attention to all the risk alerts and warnings, as well as preventive measure instructions.



Danger, observe all the warnings; there is a risk of electric shock or a situation, which can result in death or serious injury, if not prevented.



Reference to another section of the manual.



Caution – Read Operating Instructions prior to use



Protective conductor connection.



Notification of the correct position when handling and storing the packaging.



Notification of the need for protection against moisture. The product – packaging marked with this symbol must not be transported on open vehicles and stored in roofless buildings and on the ground without a pad.



Notification of the content – product's fragility and the need for careful handling of the packaged product.

FRAGILE
KEEP DRY

Notification of the need for protection against moisture and of the fragility of the product inside the packaging.

1.3. Using the Xflat 200 Unit

1.3.1. Unit Designation

- The Xflat 200 unit is an air handling unit using ventilation technology with heat recovery (counter-current heat exchanger – XF1-020-xxxxHRxxx-OA0) and humidity (enthalpic heat exchanger - XF1-020-xxxxERxxx-OA0) with the possibility of connecting an external pre-heater (not included in the unit) and an independent external air heater (not included in the unit).
- The unit can be ordered with regulation:
 - o Comfort - touch control - electronic bypass (XF1-020-ECS0xxXAC-OA0)
 - o Comfort + - touch control - mechanical bypass (XF1-020-ECS0xxXAC-1A0)
- The unit can be operated in two ventilation regimes:
 - o Manual - forced ventilation. The unit ventilates according to the output set by the user
 - o Automatic - ventilation according to air quality sensors (AQS). Air quality sensors CO₂ and RH can be connected to the unit (accessories “NL-ECO-CO2” and “NL-ECO-RH”), which allow the unit to ventilate only when necessary. If more sensors are required, up to 8 CO₂ and 8 RH sensors can be connected using the “PRO-SUM-08” accessory. The user only sets the power of the unit (flow rate) according to the required air exchange (number of people) in the ventilated and the unit ventilates according to the actual need.



- The unit can also be connected and controlled remotely:
 - o Through the BMS system using the modbus RTU communication protocol. Chapter 4.2.4.6.
 - o Via the web application using the “WifiModule” accessory. Addressed in separate Chapter 4.2.4.6.



- The unit can be used to connect the air supply from the right-hand side (right-hand version) or from the left-hand side (left-hand version). Switching between right/left version is done with a switch on the control cover (R/L) - the factory setting of the unit is right version. Addressed in separate Chapter 4.2.2.



- The unit allows switching between two nominal flow rates:
 - o 150 m³/h at disposition pressure of 200 Pa
 - o 200 m³/h at disposition pressure of 200 Pa (unit's factory setting)
- Switching the nominal flow rate of the unit is done using the switch on the control cover (150/200) - the factory setting of the unit is for a nominal flow rate of 200 m³/h. Addressed in separate Chapter 4.2.3.
- The unit is designed for vertical and horizontal wall and ceiling assemblies only).
- The unit is equipped with the “Mutiflex” system - 90° rotation of the connection throats
- The unit has constant flow technology - the flow does not decrease with increasing external pressure in the pipe (different pressure drop of individual air ducts). The unit still maintains the user's desired flow rate up to the maximum external pressure.
- The unit is designed for continuous operation with the possibility of using the manual operation regime (ventilates continuously) or the automatic operation regime (ventilates as needed – required by the air quality sensors – AQS).
- The unit is designed for indoor covered and dry areas with a room temperature of +5 °C to +30 °C and the maximum relative humidity of 70%, non-condensing.
- The maximum working altitude of the unit is 2,000 m above sea level.



- **The temperature of supplied fresh air from the outside may be between -20 °C and +40 °C (applies to the version with preheating). If the temperature of the supplied air is lower than -20 °C, the unit may be switched off automatically in order to protect it from possible damage.**

1.3.2. Prohibited environment, use, assembly of the Xflat 200 unit:



- **Exhausting burning or glowing substances!**
- **Exhausting readily flammable or explosive gases,**
- **Exhausting aggressive media,**
- **Exhausting liquids of any kind,**
- **In an environment with an increased incidence or risk of explosion, flammable substances, and increased dust and/or air containing other harmful impurities,**
- **In an environment with higher condensation humidity, such as: bathrooms, swimming pools, saunas ...**
- **The unit must not be installed just below the electrical socket or wiring box,**

- Neither the manufacturer nor the supplier is liable for damage caused by improper use of the units (e.g.: drying out of new buildings). The user bears the risk.

1.4. Transport, Delivery Control, and Storage

1.4.1. Transport

- During transport, keep the product in the position indicated by the symbol on the packaging.
- The packaging must not be loaded with a weight higher than that permitted by the manufacturer.
- The packaging must not be exposed to ambient effects.
- The transport air temperature must range between -25 to 55 °C.
- The transport relative humidity must range between 10 % and 90 % non-condensing.
- **Use adequate tools to prevent damage to the goods and damage to the health and safety of persons.**
- In the case of further transport without original packaging or with changed original packaging, it must be ensured that the equipment is optimally secured and protected against damage.



1.4.2. Delivery Inspection

- Before starting the assembly and before unpacking the unit from the box, it is necessary to check for any signs of packaging damage. If the packaging is damaged, write a record of the damage and contact your carrier, please.
- Check if you have received the product actually ordered by you. After unpacking, check that the unit and other components are in order. Please, report any discrepancy with the order to the supplier immediately. If an order complaint is not made immediately after delivery, it will not be considered later.

1.4.3. Storage

- If you do not plan to install the unit immediately after purchase, it must be stored in an indoor, non-condensing environment at temperatures ranging between +5 to +40 °C. If the product is transported at temperatures below 0 °C, it must be put into the working environment where it will be installed for at least 2 hours after unpacking.

1.5. Xflat 200 Unit Package Contents

- | | |
|--|----|
| - Xflat 200 unit | 1x |
| - Siphon hose \varnothing 18/14- 2000 mm for condensate drainage | 1x |
| - Tie strap 2,5x120 | 2x |
| - Quick manual + Safety data sheet | 1x |
| - Serial plate | 1x |
| - Energy label | 1x |
| - Pads | 8x |
| - Round throat seal | 4x |
| - Control panel with 10 m communication cable | 1x |

1.6. Before Starting the Assembly

- Before starting the assembly, we recommend attaching the serial plate (by default, supplied with the package) to the operating documentation (e.g.: equipment operating book, etc.), which is subsequently kept for a later maintenance records and servicing.
- **Check that there are no electrical or other lines (e.g. gas, water, etc.) at the point of assembly of the unit on the wall that could be damaged during assembly.**
- **Make sure that the assembly of the unit, including openings in the wall, wall (depending on the chosen assembly position) for the passage of the connection pipe, does not endanger the statics of the building and meets all the legislative requirements for safety.**
- Check the solution for draining the unit's condensate into the sewer system or in another way that ensures smooth condensate drainage



2. Technical parametrs

2.1. Basic part unit

Fig. 1

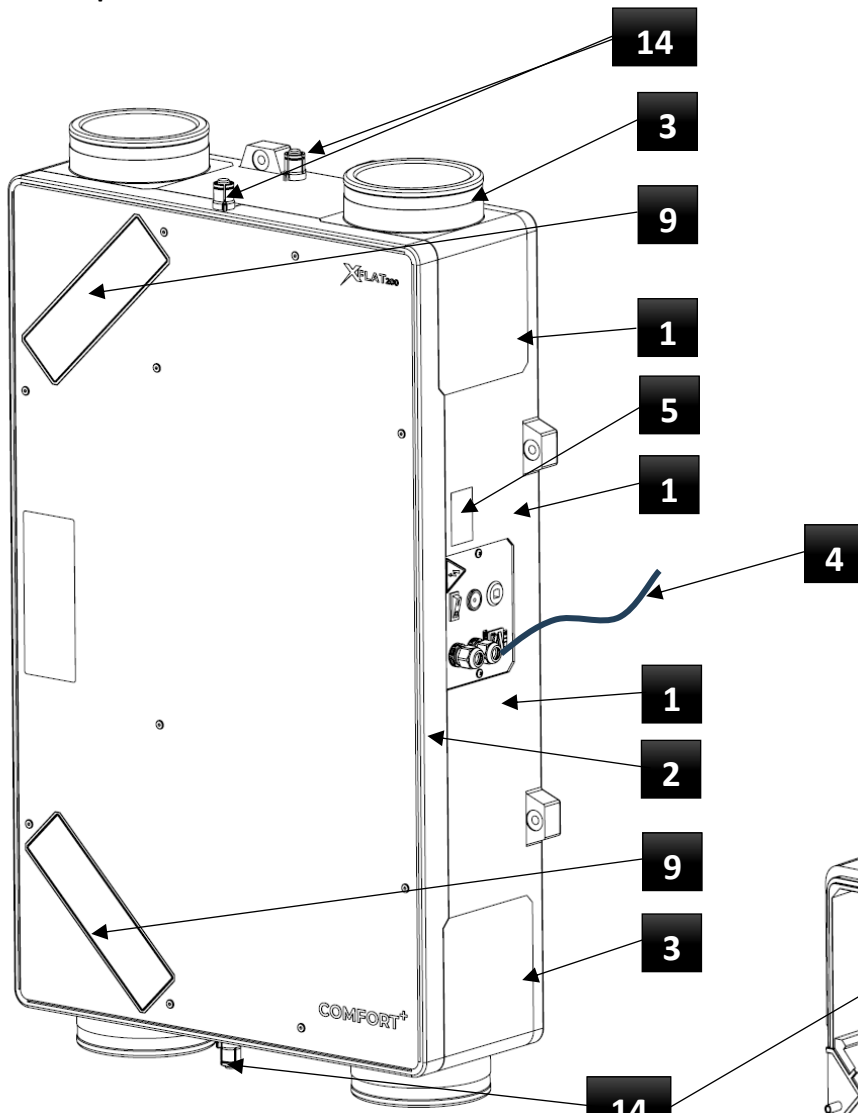
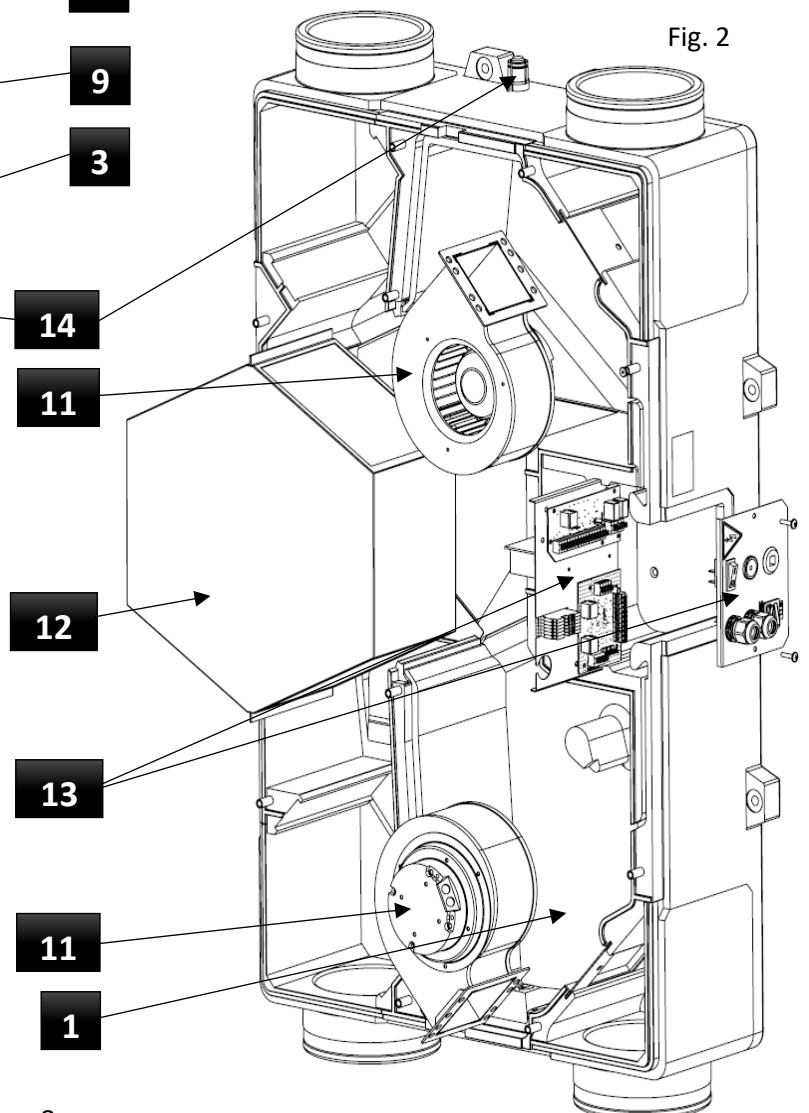

Fig. 2



Regulation detail

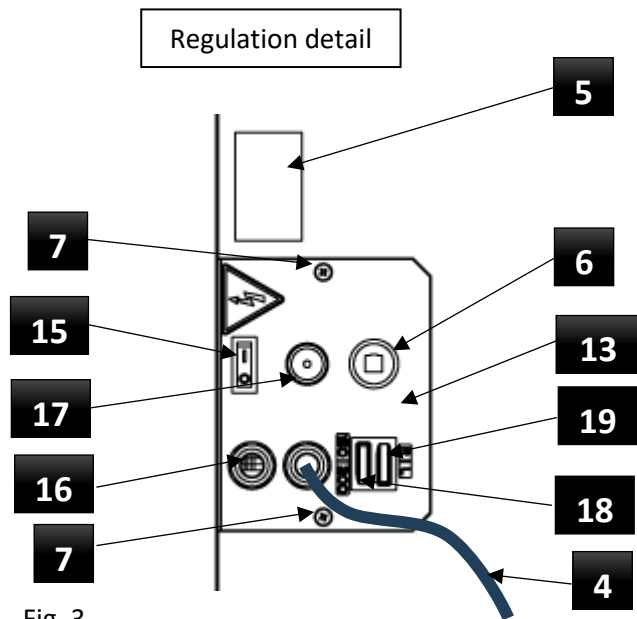

Fig. 3

2.1.1. Unit Body – Fitting (position 1)

- The body of the unit is made of black pressed EPP plastic (expanded polypropylene). It ensures the accuracy and repeatability of the assembly of components. The material itself is an advanced technical material with a unique combination of properties, such as strength at low weight, rebound elasticity, thermal insulation, chemical resistance, sound insulation, and recyclability.

2.1.2. Unit cover (position 2)

- The unit cover is made of black pressed EPP plastic (expanded polypropylene).

2.1.3. Connection throats - Swivel Corners (position 3.)

- The $\varnothing 130/\varnothing 160$ mm (inner/outer diameter) connection throats are made of EPP material. To increase the variability of the connection, it is possible to rotate the throat by 90° after opening the lid, thus allowing a direct connection of the pipe to the unit without the need for an elbow (the 90° rotation has no effect on the advertised ventilation parameters).

2.1.4. Supply cable (position 4)

- It connects the unit and the connection point from the mains. Cable length approx. 1 m. The CYSY 3x1.5 mm² cable type with stripped and marked ends of 50 mm.

2.1.5. Production label (position 5)

- Displays the electrical and other technical parameters of the unit.

2.1.6. RJ connector (position 6)

- The RJ connector is used to connect the controller to the unit.

2.1.7. Tapping Screw $\varnothing 4.2 \times 13$ (position 7)

- Tapping screw (2 pcs) attaches the regulation cover plate. Head type pozidrive size 1.

2.1.8. Bolt M6x25 (position 8)

- Galvanized flat head hexagon socket head cap screw M6x25 (10 pcs) size 2.

2.1.9. Filter caps (position 9)

- Filter caps are used to seal the filters in the unit cover. They are made of black pressed EPP plastic (expanded polypropylene).

2.1.10. Filters (position 10)

- M5 filters (ISO COARSE 70%) are included in the delivery. F7 filters (ISO ePM1 60%) can be supplied upon request. Evaluation of filters per ČSN EN ISO 16890

2.1.11. Fans (position 11)

- The plastic radiant fan with EC motor from leading European manufacturers ensures smooth operation, minimal power consumption, and long service life of the unit.

2.1.12. Recuperator (position 12)

- The counterflow recuperator ensures heat recovery with maximum efficiency (XF1-020-ECxxHR...). In the version with the enthalpy exchanger (XF1-020-ECxxER...), it also allows the transfer of moisture back into the ventilated space.

2.1.13. Regulation Box (position 13)

- It ensures interconnection of the individual components and also serves for the customer's connection.

2.1.14. Condensate outlet (position 14)

- Plastic condensate drain made of ABS material. It is used to drain condensate from the unit.

2.1.15. Main switch (position 15)

- The 1-pole main switch is used to connect/disconnect the unit from the mains.

2.1.16. Screw grommet (position 16)

- It is designed for the communication cable penetration (e.g.: UTP) to connect the unit to the parent BMS system and the supply cable. As standard, the cables are routed through grommets.

2.1.17. Membrane multi-grommet (position 17)

- The multi-grommet is used to connect external accessories to the unit while maintaining the IP rating

2.1.18. Right/left unit version switch

- Switching between right (marked on unit R - factory setting) and left (marked on unit L) version

2.1.19. Unit nominal air capacity switch

- Switching between two air capacities 150m³/h and 200m³/h (factory setting)

2.2. Main dimensions of the Xflat 200 unit

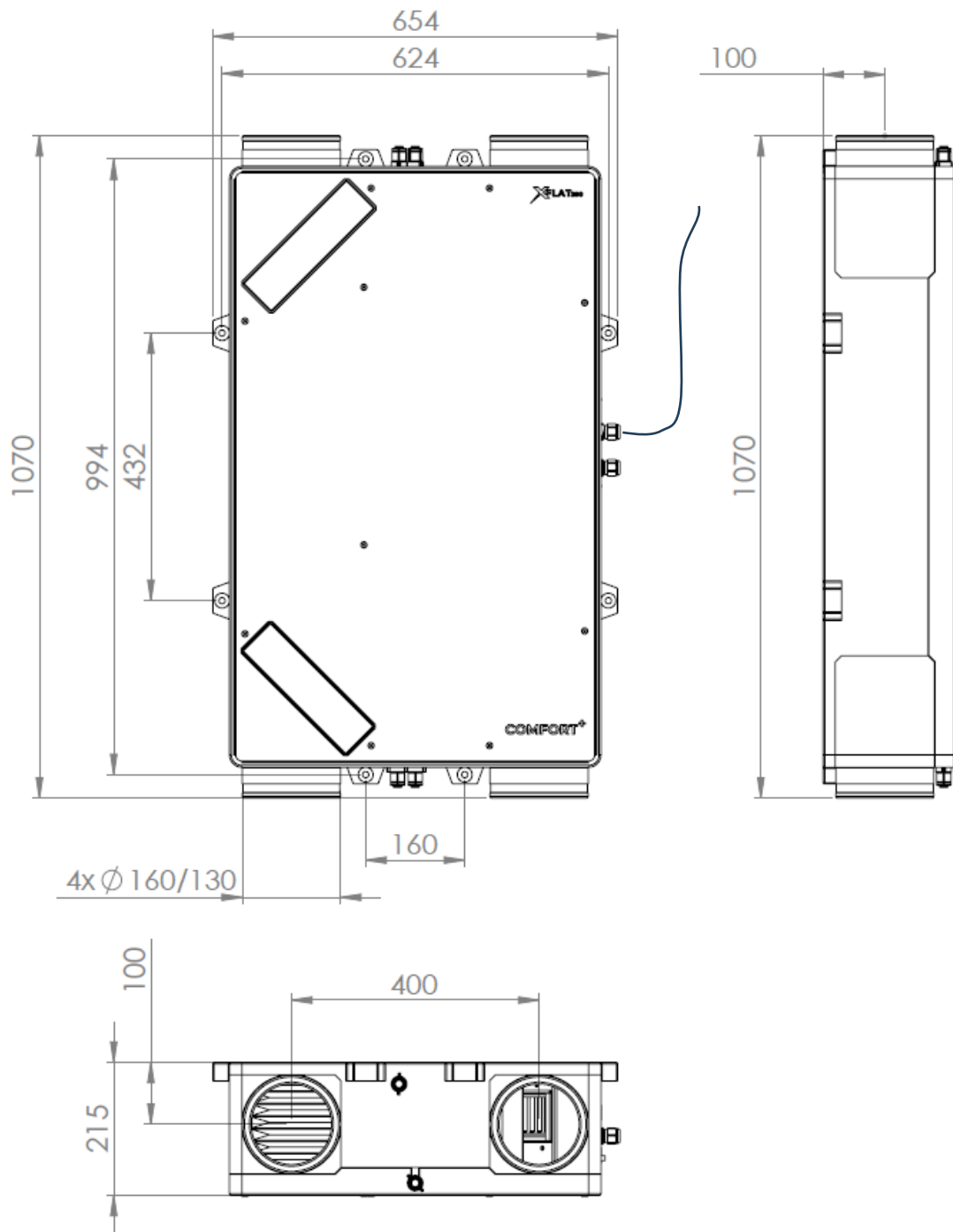

Fig. 4

2.3. Technical parameters of Xflat 200 units

2.3.1. Basic Technical Parameters

- Basic Technical Parameters - Xflat 200

Tab. 1

Type Xflat		Xflat 200 - Comfort		Xflat 200 - Comfort+	
		XF1-020-ECS0HRXAC-0A0	XF1-020-ECS0ERXAC-0A0	XF1-020-ECS0HRXAC-1A0	XF1-020-ECS0ERXAC-1A0
Type of recovery exchanger		HRV - temperature	ERV - Temperature/Humidity	HRV - temperature	ERV - Temperature/Humidity
Bypass type		Electronic	Electronic	Mechanical	Mechanical
Nominal airflow*	m ³ /hour	155/207			
Acoustic level**	dB(A)	31.4/35.1			
Weight***	kg	16		16,5	
Power supply	V/Hz	1 ~ 230 / 50-60			
Nominal input****	W	104 / 172 (181)			
Nominal current*****	A	0.74 / 1.22 (1.29)			
Thermal efficiency *****	Heat	89.3/88	80.5/78	89.3/88	80.5/78
	Humidity	-	43/40	-	43/40
Electric safety	IP	20			
Energy class (ERP)*****	-	Cold climate A+, mid climate A, warm climate E / Cold climate A+, mid climate A+, warm climate E			

* Nominal airflow for 150/200 m3/h (power input, current) at external pressure drop of 200Pa,

** Sound pressure level in free space at a distance of 3m (Q2) - for an air output of 150/200 m3/h

*** Unit weight without packaging

**** Power consumption, current - for air flow 150/200 m3/h (max. possible power consumption, current)

***** Heat recovery efficiency stated at 70% of nominal flow according to EN 308 - for air output 150/200 m3/h

***** Energy efficiency class (ERP) - for air flow rate 150/200 m3/h

- Performance Characteristics of the Unit - Xflat 200

Performance characteristics of the XFLAT 200 unit
for nominal flow - 150 m3/h - HRV / ERV

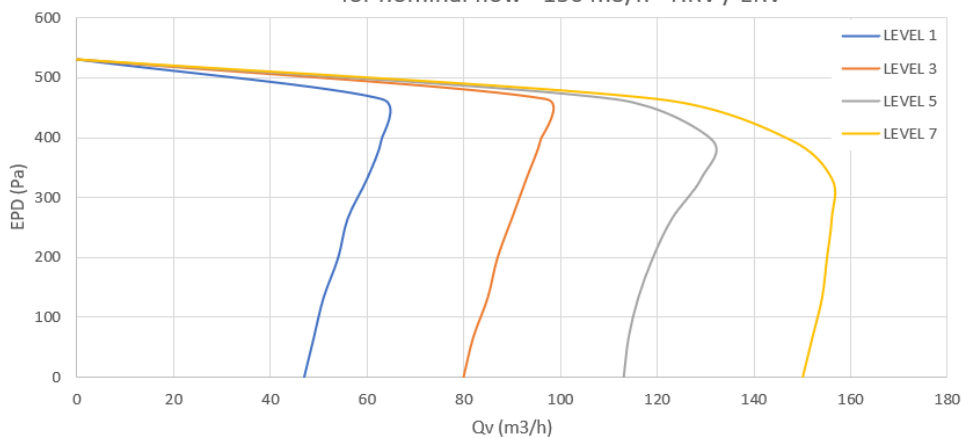

Chart. 1

Performance characteristics of the XFLAT 200 unit
for nominal flow - 200 m3/h - HRV / ERV

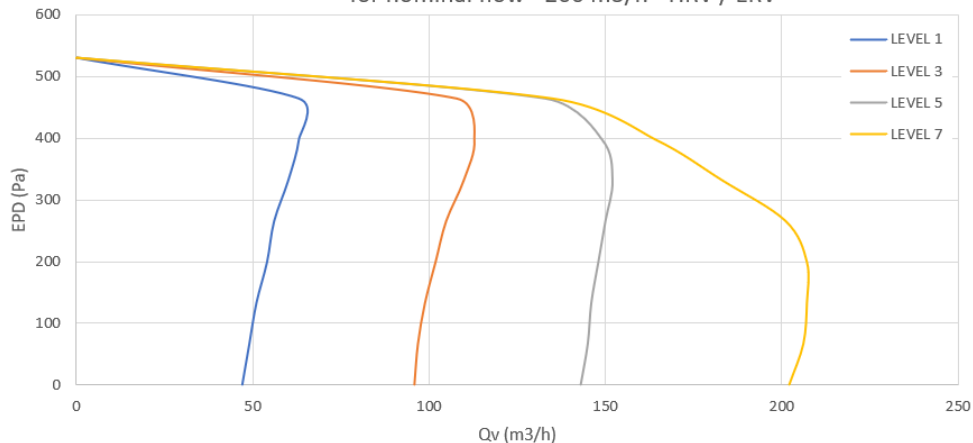

Chart. 2

EC Declaration of Conformity – the current and full version of the EC Declaration of Conformity can be found on our website www.xvent.cz in the “Download Documents” section for the Xflat product

2.3.2. Xflat - 200 Acoustic Data

- Nominal Flow 150 m³/h

- Unit radiates to the interior (inside the room)

Tab. 2

Air output level	Air output	Sound power level LWA [dB (A)]									Sound pressure level in the open field on the reflection plane	
		63 Hz	125 Hz	250 Hz	500 Hz	1 kHz	2 kHz	4 kHz	8 kHz	L _{WA}	1.5 m	3 m
LED on the controller	(m ³ /h)	(dBA)	(dBA)	(dBA)	(dBA)	(dBA)	(dBA)	(dBA)	(dBA)	(dBA)	LPA (dBA)	LPA (dBA)
1.	49	-	12,1	23,6	23,8	22,3	15,0	13,2	12,5	31,7	<20	<20
4.	102	17,3	26,5	34,1	30,4	38,6	28,5	22,4	14,4	44,0	30,6	22,7
7. - Nominal*	155	26,5	35,5	44,3	39,3	44,1	40,3	35,4	25,9	52,7	39,3	31,4

* Nominal flow rate is the same as BOOST mode - intensive ventilation for a set period of time (ventilation intensity and ventilation time can be set in the customer menu)

- Unit radiates into the duct - nominal air output

Tab. 3

Connecting throats	Sound power level LWA [dB (A)]									
	63 Hz	125 Hz	250 Hz	500 Hz	1 kHz	2 kHz	4 kHz	8 kHz	L _{WA}	
	(dBA)	(dBA)	(dBA)	(dBA)	(dBA)	(dBA)	(dBA)	(dBA)	(dBA)	(dBA)
ODA	32,4	43,8	39,2	37,5	35,9	25,4	19,8	15,8	54,9	
SUP	47,9	51,6	56,4	55,1	52,0	51,9	49,7	45,7	66,8	
ETA	32,4	42,0	45,1	37,8	37,0	28,8	21,7	16,5	55,0	
EHA	48,1	52,5	56,1	52,9	55,2	51,4	50,3	46,4	67,2	

- Nominal Flow 200 m³/h

- Unit radiates to the interior (inside the room)

Tab. 4

Air output level	Air output	Sound power level LWA [dB (A)]									Sound pressure level in the open field on the reflection plane	
		63 Hz	125 Hz	250 Hz	500 Hz	1 kHz	2 kHz	4 kHz	8 kHz	L _{WA}	1.5 m	3 m
LED on the controller	(m ³ /h)	(dBA)	(dBA)	(dBA)	(dBA)	(dBA)	(dBA)	(dBA)	(dBA)	(dBA)	LPA (dBA)	LPA (dBA)
1.	48	-	11,9	23,3	23,5	22,0	14,8	12,9	12,3	31,4	<20	<20
4.	123	17,6	27,3	36,3	31,9	40,0	30,6	24,5	15,4	45,7	32,3	24,4
7. - Nominal	207	30,5	38,7	47,7	42,7	47,5	45,8	40,0	31,0	56,5	43,0	35,1

* Nominal flow rate is the same as BOOST mode - intensive ventilation for a set period of time (ventilation intensity and ventilation time can be set in the customer menu)

- Unit radiates into the duct - nominal air output

Tab. 5

Connecting throats	Sound power level LWA [dB (A)]									
	63 Hz	125 Hz	250 Hz	500 Hz	1 kHz	2 kHz	4 kHz	8 kHz	L _{WA}	
	(dBA)	(dBA)	(dBA)	(dBA)	(dBA)	(dBA)	(dBA)	(dBA)	(dBA)	(dBA)
ODA	37,1	47,0	42,6	40,8	38,7	29,5	25,3	19,8	57,6	
SUP	50,0	54,3	59,5	58,9	55,4	58,1	54,4	50,8	70,1	
ETA	36,0	44,6	48,0	41,4	39,4	33,4	26,2	21,0	57,7	
EHA	52,1	56,1	58,9	55,9	58,2	56,7	53,9	51,0	70,1	

2.3.3. Heat and Moisture Recovery Efficiency - Xflat - 200

Tab. 6

- **Nominal flow 150 m³/h**

Business name		Xflat200								
Unit type		XF1-020-ECS0HRXAx-xA0				XF1-020-ECS0ERXAx-xA0				
Nominal output		155 m ³ /h				155 m ³ /h				
Type of recuperator		HRV - temperature				ERV - temperature/humidity				
		Flow rate (m ³ /h)	Temperature % efficiency (EN308)	Current (A)	Power supply (W)	Flow rate (m ³ /h)	Temperature % efficiency (EN308)	Humidity efficiency % (EN308)	Current (A)	Power supply (W)
Air output level	1.	49	92	0,12	13	49	87,4	47,2	0,12	13
	2.	68	90,6	0,15	18	68	84,7	44,9	0,1	18
	3.	83	90	0,18	23	83	82,8	43,2	0,18	23
	4.	102	89,35	0,26	35	102	80,8	41,2	0,26	35
	5.	120	88,8	0,36	51	120	79,2	39,4	0,36	51
	6.	138	88,1	0,51	72	138	77,9	37,6	0,51	72
	7. - nominal	155	87,5	0,74	104	155	76,8	36,1	0,74	104
	8. BOOST*	155	87,5	0,74	104	155	76,8	36,1	0,7	104

* BOOST mode - intensive ventilation for a set period of time (ventilation intensity and ventilation time can be set in the customer menu)

EFFICIENCY DIAGRAM - HRV - XF1-020-ECS0HRXAx-xA0

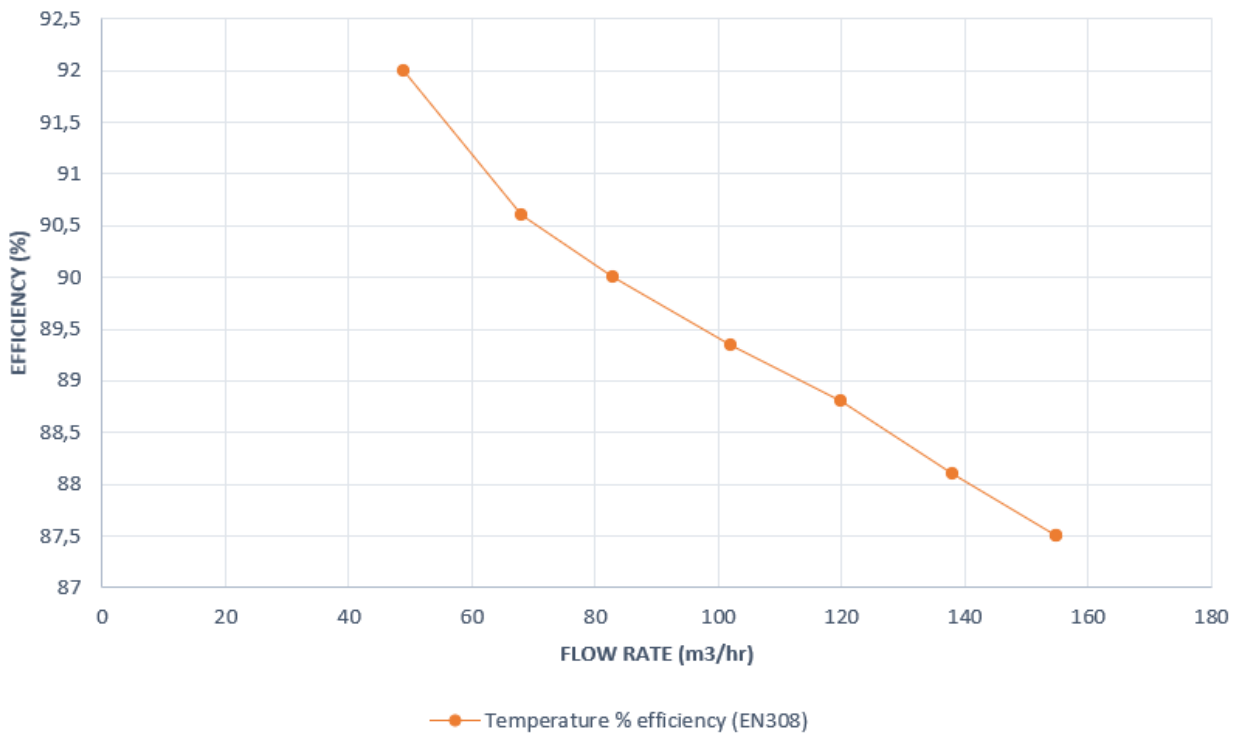

EFFICIENCY DIAGRAM - ERV - XF1-020-ECS0ERXAx-xA0

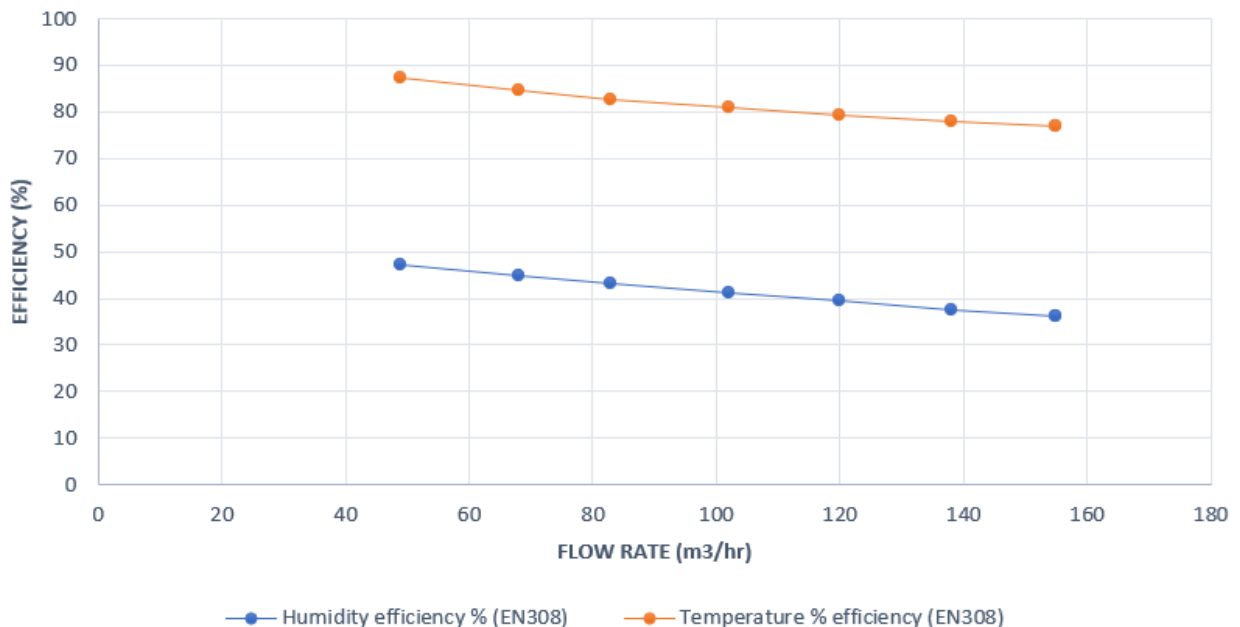

- Nominal flow 200 m³/h

Tab. 7

Business name		Xflat200								
Unit type		XF1-020-ECS0HRXAx-xA0				XF1-020-ECS0ERXAx-xA0				
Nominal output		207 m ³ /h				207 m ³ /h				
Type of recuperator		HRV - temperature				ERV - temperature/humidity				
		Flow rate (m ³ /h)	Temperature % efficiency (EN308)	Current (A)	Power supply (W)	Flow rate (m ³ /h)	Temperature % efficiency (EN308)	Humidity efficiency % (EN308)	Current (A)	Power supply (W)
Air output level	1.	48	92	0,11	12	48	87,4	47,2	0,11	12
	2.	73	90,1	0,15	18	73	84	44,3	0,1	18
	3.	95	89,5	0,20	26	95	81,5	42	0,20	26
	4.	123	88,4	0,31	43	123	79	39,1	0,31	43
	5.	146	87,7	0,47	66	146	77,3	37	0,47	66
	6.	181	86,6	0,89	126	181	75,4	33,8	0,89	126
	7. - nominal	207	85,9	1,22	173	207	74,2	31,6	1,22	173
	8. BOOST*	207	85,9	1,22	173	207	74,2	31,6	1,2	173

* BOOST mode - intensive ventilation for a set period of time (ventilation intensity and ventilation time can be set in the customer menu)

EFFICIENCY DIAGRAM - HRV - XF1-020-ECS0HRXAx-xA0

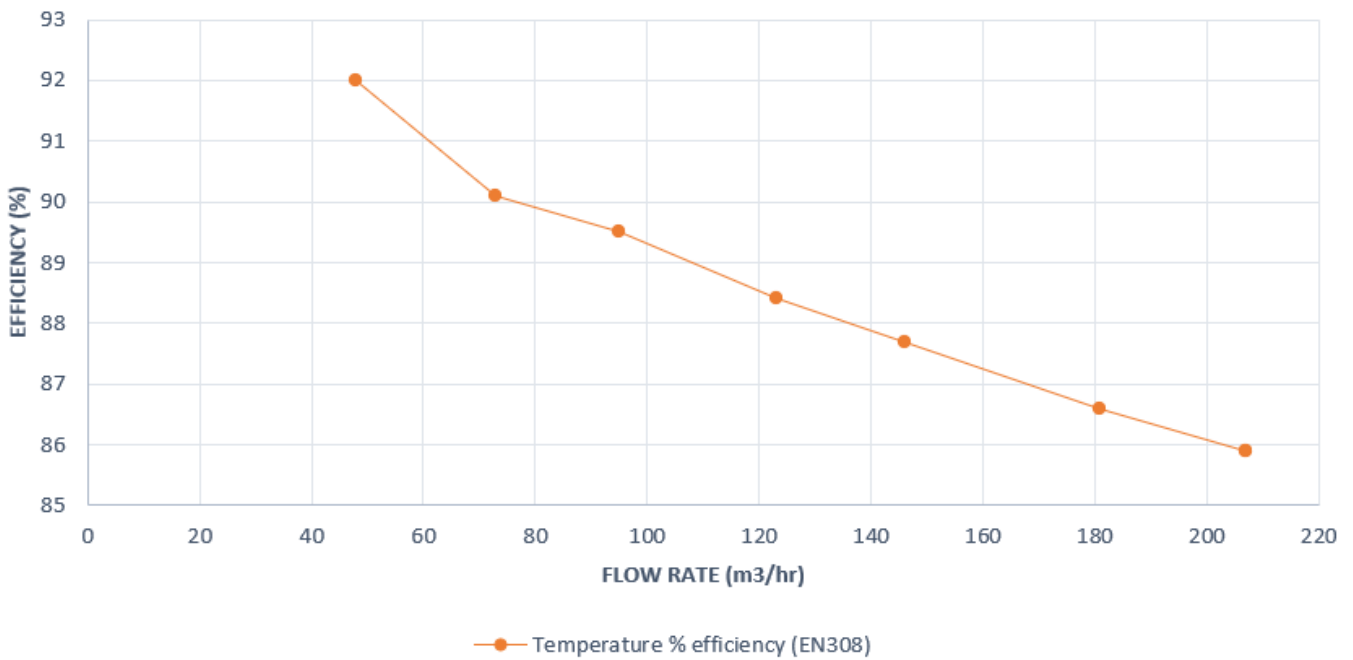

EFFICIENCY DIAGRAM - ERV - XF1-020-ECS0ERXAx-xA0

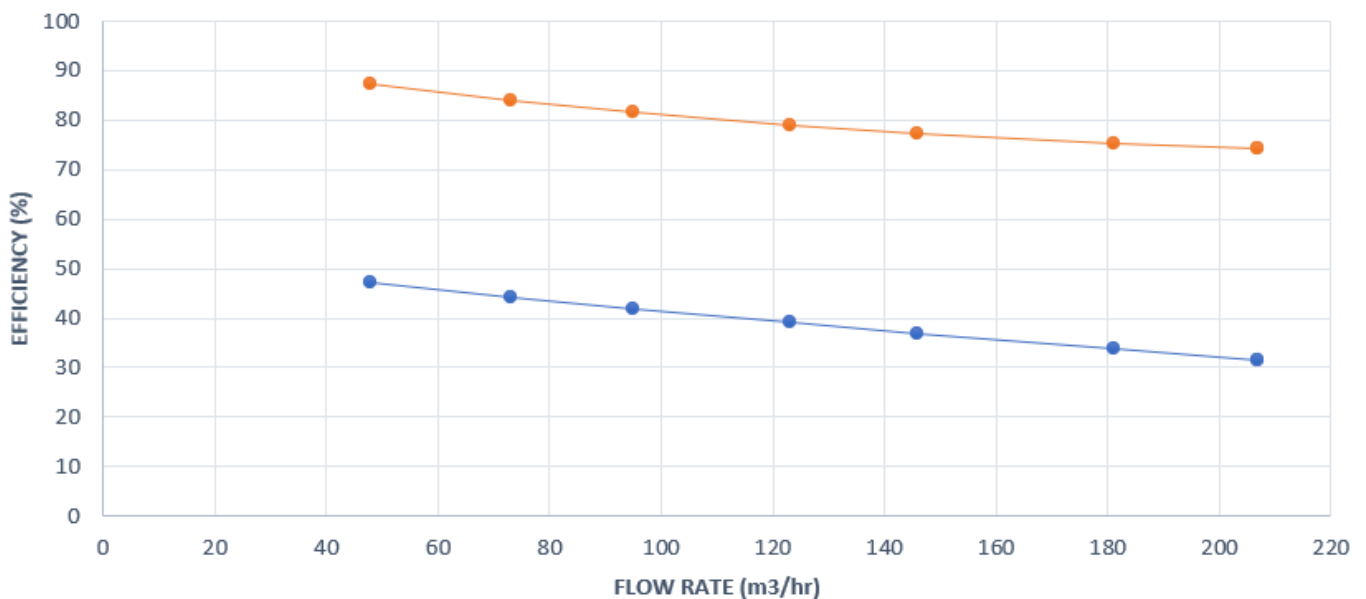

3. Unit Assembly

3.1. General information, recommendations, and safety when assembling the Xflat 200 unit

3.1.1. Electrical safety before the unit assembly



- Before starting any assembly work, make sure that the wiring box or mains socket that you want to use to connect the unit is equipped with a protective (green-yellow) conductor or contact (pin).
- If you use a wiring box to electrically connect the unit, you must turn off the power and secure the power supply against accidental turn on.



Check that the electrical connection point (wiring box, outlet) meets the unit's power supply requirements (voltage, current, etc.) specified on the unit's serial plate. The electrical quantities necessary for the unit's operation can be found in Section 3.3.3. Display of Electrical Parameters

3.1.2. Unpacking the Xflat 200 Unit

- Always unpack the unit in a sufficiently large area to allow for removing the unit from the packaging.
- Never unpack the entire unit from the packaging, the unpacking of the unit must be gradual, as specified in this manual according to the assembly work in progress (protection of the unit from damage and dust generated during assembly)

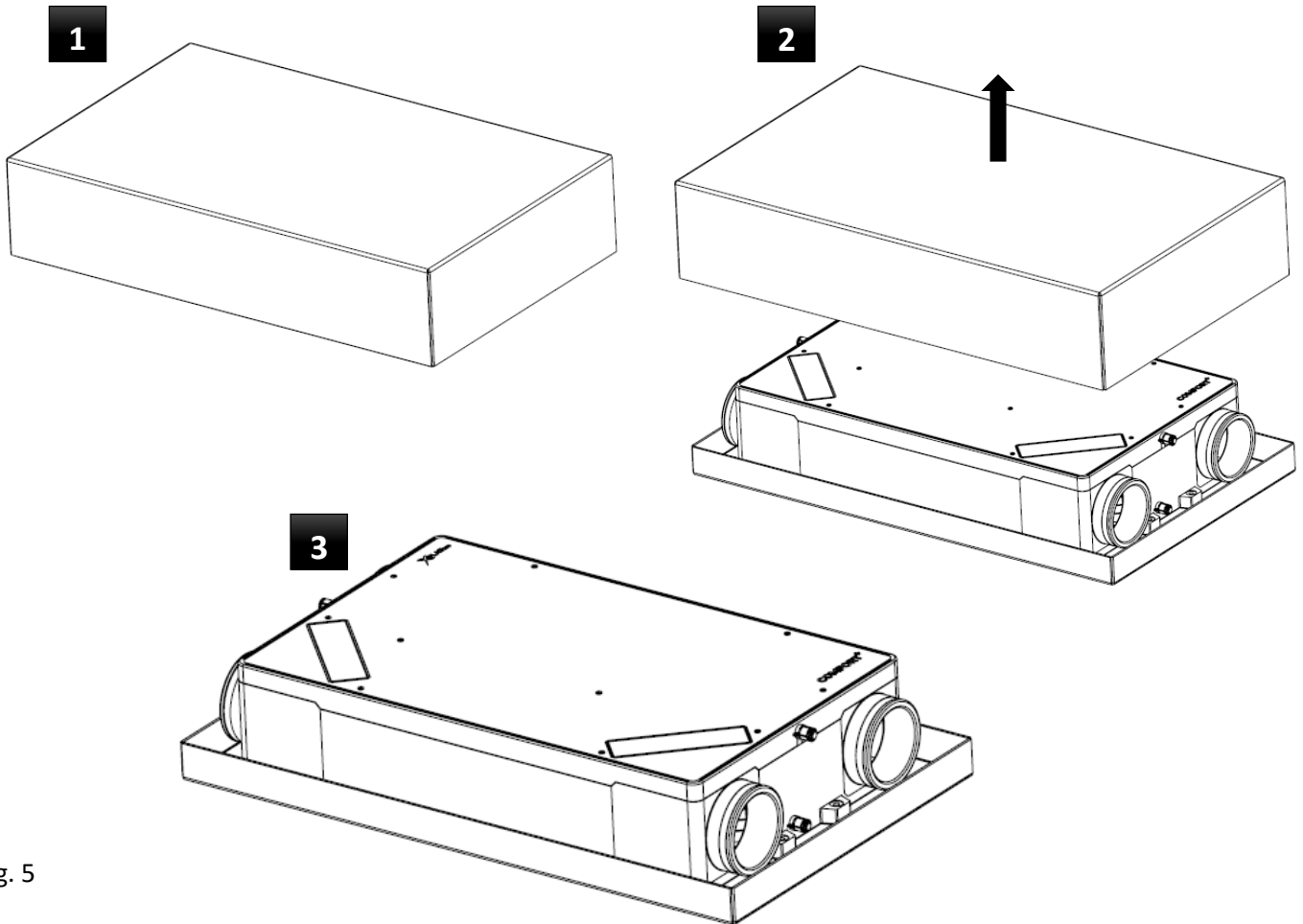
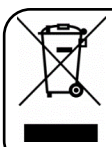

Fig. 5



Please, return all the not needed packaging to the appropriate recycling points where they will be disposed of professionally. Only packaging recycled in this way can be reused properly and returned to utility.



3.1.3. Unit Location



- When selecting a location for the assembly of the unit, always consider the layout of the building within the overall HVAC system (e.g.: location of dampers, supply and exhaust ducts, etc..). Consult an HVAC designer or a person knowledgeable in the field for the proper design of the entire HVAC system. The manufacturer is in no way responsible for the design of the ventilation system.

- The unit is to be installed in indoor covered and dry areas with a room temperature of +5 °C to +30 °C and with maximum relative humidity of 70% non-condensing.



- Consider the location of the unit indoor away from surrounding objects in relation to the recommended clearances from the unit (e.g.: filter changes, opening the unit - servicing) as given in Chapter 3.1.4.

- Check your options for connecting the condensate outlet to the waste pipe.

3.1.3.1. Location and operation of the unit in the area with a furnace (fire place)

- If the air ducts are located in rooms with a furnace, you can set the fan distribution in the customer menu (more air is supplied than exhausted). The fan balancing cannot replace the separate air supply to the heater in any way due to the possibility of controlling by AQS sensors.
- For proper operation of the furnace and the unit, consult the location with the chimney sweep. Otherwise, the unit may malfunction.

3.1.3.2. Unit Location and Operation in the Area with an Air Conditioning Unit

- When operating the unit during the summer months and using the air conditioner in a ventilated area, condensation may form inside the unit in the opposite supply branch.
- For trouble-free operation, we recommend installing a unit equipped with an enthalpy exchanger (XF1-020-ECS0ERXAx-xA0).

3.1.4. Minimum Assembly Distances

- Distances from fixed objects:

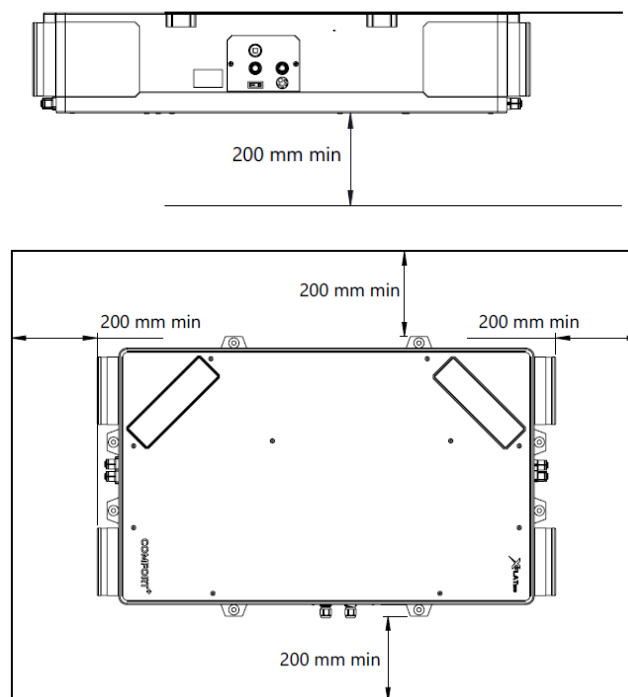

Fig. 6

- The unit must be installed and adjusted (right/left version switch – position 18.) in such a way that the direction of air flow through the unit itself is identical to the air flow in the air handling system.
- Failure to observe the specified clearances may not work properly and may damage the fan, increase noise, or prevent service access to the unit.

3.1.5. Permitted installation positions of the Xflat 200 unit according to the switch setting (position 18) of the unit version right/left

3.1.5.1. The right version of the unit – switch switched to position “R” – factory setting

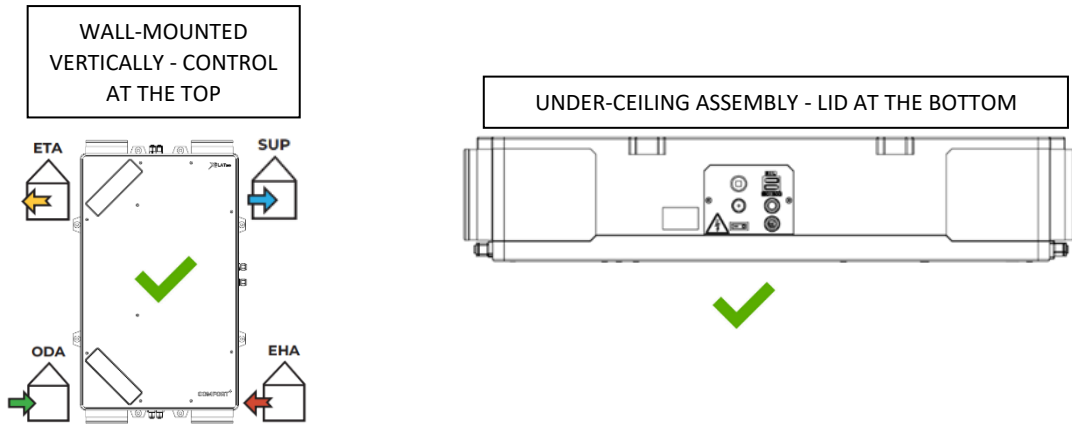

Fig. 7

3.1.5.2. Left version of the unit – switch switched to the "L" position

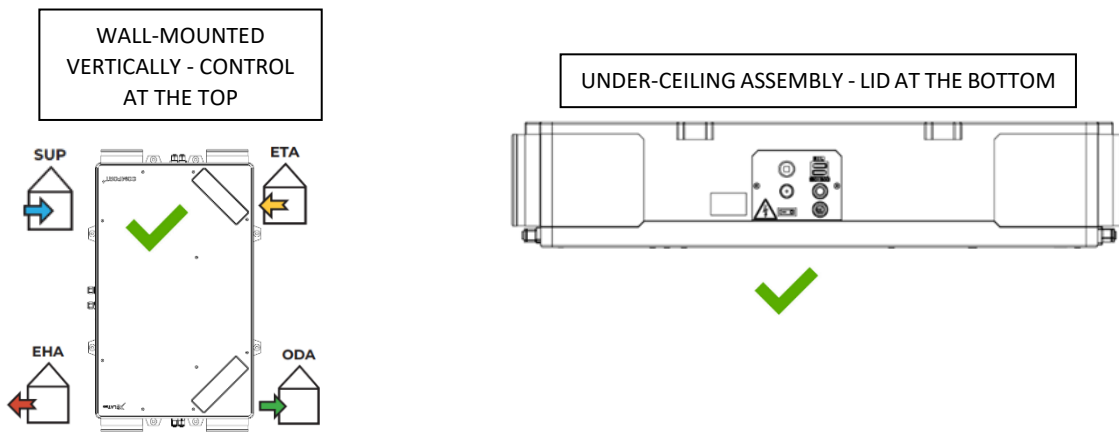

Fig. 8



- Any other position is prohibited
- The unit must always be accessible from the front (lid side) for access to the filters and for servicing. If the unit is placed under a wall, ceiling (bricked up) the wall, ceiling must be provided with an inspection hole for access to the unit.

3.1.6. Prohibited assembly positions of the Xflat 200 unit

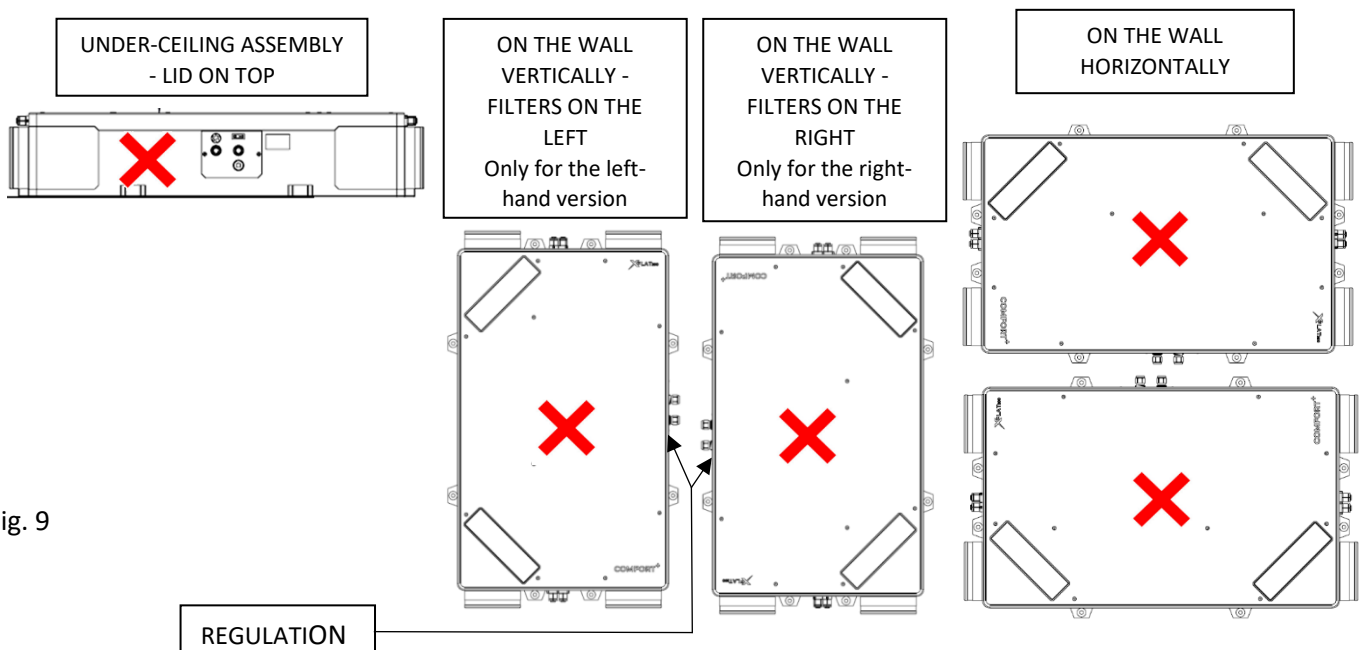

Fig. 9

3.2. Xflat 200 Unit Assembly

- The unit must be operated in enclosed and dry areas with room temperature ranging between +5 °C and +30 °C.
- The recovery unit must be installed in accordance with the general and local safety regulations.
- The recovery unit may be installed, connected, commissioned, and repaired by a person with adequate education, experience, and knowledge of applicable regulations, standards, and potential risks and hazards, or by a properly trained service technician.
- **Failure to follow the assembly procedure may result in the unit's damage or malfunction, or potential harm to the health and property of the user.**
- **Take special care when draining the condensate using a condensation tray (not a part of the supply) into the sewerage piping. The unit manufacturer accepts no liability for damage caused by incorrect assembly of the condensation tray, drain piping, and other peripherals required for their operation.**



3.2.1. Mounting equipment required to assemble the Xflat 200 - general requirements

- Prepare the auxiliary assembly material for the assembly of the unit:
 - o Anchoring elements (e.g.: dowels, dowel screws) 6 - 8 pcs
- Select the anchoring material according to the wall or ceiling construction, the weight of the unit, and the weight of the connected peripherals.



The unit variant weights are given in item 2.3.1. "Basic technical parameters"

The unit dimensions are given in item 2.2. "Basic dimensions of the Xflat 200 unit"

3.2.2. Positioning, assembly of the unit on the wall or ceiling

- Select the appropriate anchoring material (not included) according to the composition of the wall, ceiling. To use the unit's suspension system, choose a screw with max. Ø8mm
- **The wall or ceiling to which you anchor the unit must always be sufficiently strong and cohesive. If necessary, contact a specialist in the field - structural engineer.**
- Use a spirit level to measure the anchor holes for attaching the unit. Alternatively, place the unit against a wall or ceiling and use a spirit level to set it level.
- Draw the mounting holes for anchoring the unit.

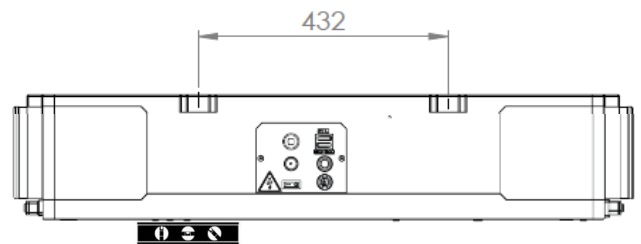
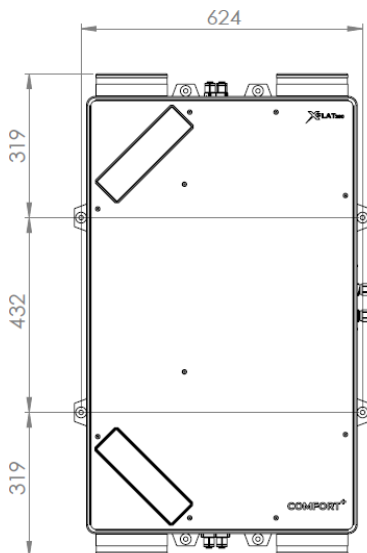

Fig. 10

- Drill holes for anchoring, fix with suitable anchoring material (dowels) using washers on individual feet and screw the unit in. Consider using oval holes to anchor the unit in the anchor footings.
- Tighten the anchor bolts adequately to secure the unit against any undesired movement - falling.
- **Make sure the unit is set correctly LEVEL using a spirit level, NEVER TILT THE UNIT in any direction.**



3.2.3. Mounting the unit controller

- The controller is supplied as standard with the unit and a 10m long communication cable. The free side of the cable is equipped with a non-removable RJ45 8/8 connector. The other side of the communication cable is plugged into the controller. The controller is designed for wall assembly
- **The RJ connector must be protected against damage throughout the assembly of both the unit and the controller. If it is necessary to pull the communication cable through a building cavity (e.g.: through a protective sleeve), take care to protect the RJ connector against damage, or disconnect the communication cable on the controller side - see Chapter 3.2.3.4.**
- Preparations of communication peripherals may only be carried out by persons qualified for this activity with valid authorization and knowledge of the relevant standards and guidelines in the country concerned.



3.2.3.1. Basic controller dimensions

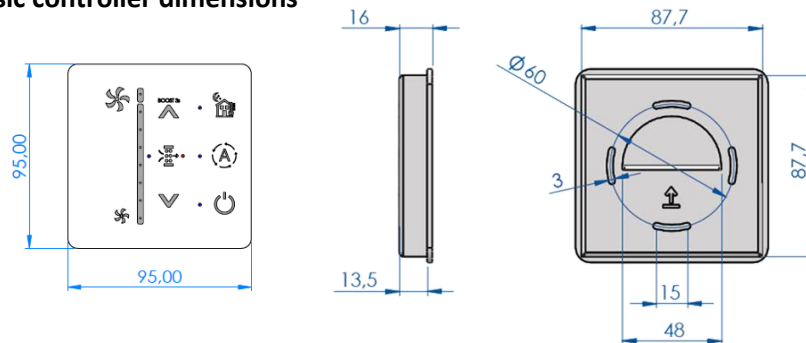

Fig. 11

3.2.3.2. Assembly of the controller on the wall - standard length of the communication cable 10 m

- Open the controller box - the front of the box is connected to the rear by magnets, use reasonable force to open the box to avoid damaging the controller.

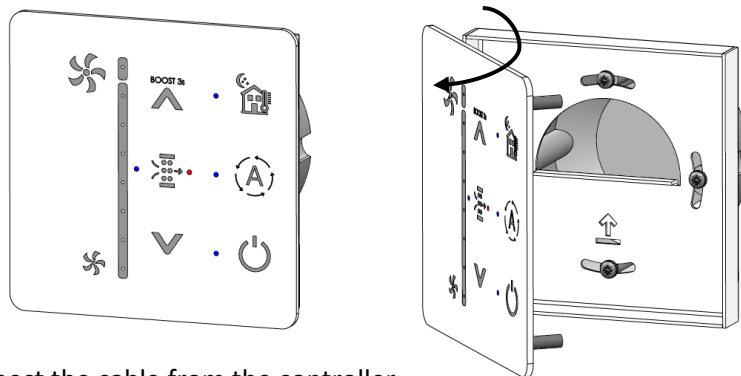

Fig. 12

- Do not disconnect the cable from the controller
- Screw the rear metal part of the controller to the wiring box with adequate fasteners.

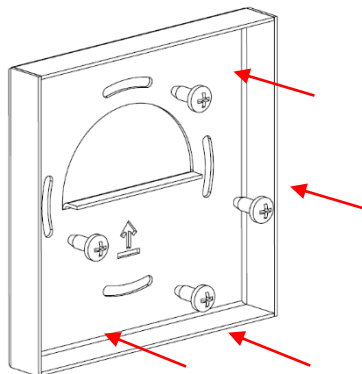

Fig. 13

- **Secure the cable route between the unit and the controller so that it is stable and cannot be accidentally damaged, damaged or even possibly jammed from another source.**
- **Connect the free communication cable with RJ connector to the unit - see Chapter 3.2.3.3.**



3.2.3.3. Connecting the unit and the controller

- Insert the free end of the communication cable with RJ connector (male) into the RJ connector (female) on the cover plate of the control unit

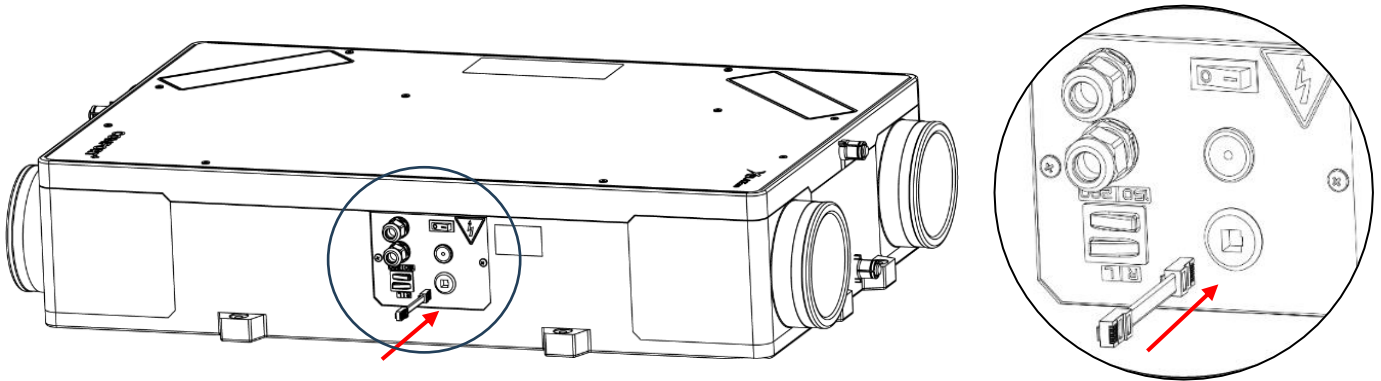
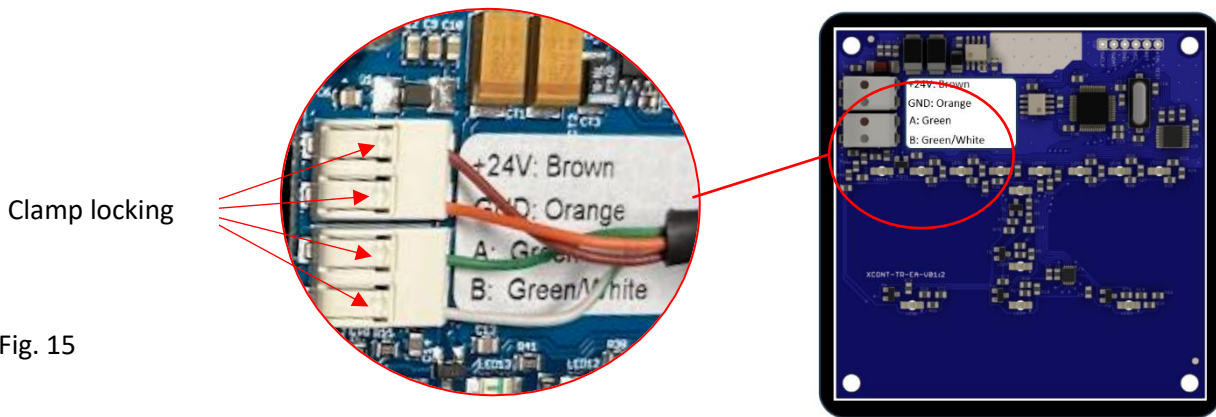

Fig. 14

3.2.3.4. Disconnecting the communication cable from the controller

- If necessary, the connected end of the communication cable can be disconnected from the controller, e.g.: when the cable is pulled through a construction cavity (protector).
- Spring clamps with manual wire locking are used for conductor connection. A conductor with a solid conductor (wire) in the cross-section range from 0.2 to 0.75 mm² must be installed in the terminals.
- Before inserting the conductor into the terminals, first, with a flat screwdriver of appropriate size (max. width 1.5 mm), squeeze the lock on the terminal. Then insert the conductor, release the lock and check that the conductor is properly secured by pulling lightly on the clamp. If the conductor needs to be removed from the terminal, the procedure is the same.



Clamp locking

Fig. 15



- Use adequate force to release the clamp lock to prevent damage to the clamp or the DPS controller. The insulation stripping on individual conductors must be in the range of 7 - 9 mm.

3.2.3.5. Assembling the controller on the wall - external communication cable

- The communication cable to connect the unit and the controller may be part of the construction preparation or the standard cable length may be insufficient.
- Make sure to secure the cable for assembly:
 - o 8-core UTP cable with RJ45 8/8 terminals
 - o The maximum length of the communication cable between the unit and the controller is 50 m.
- Prepare the end of the communication cable to which you will connect the controller - strip it:

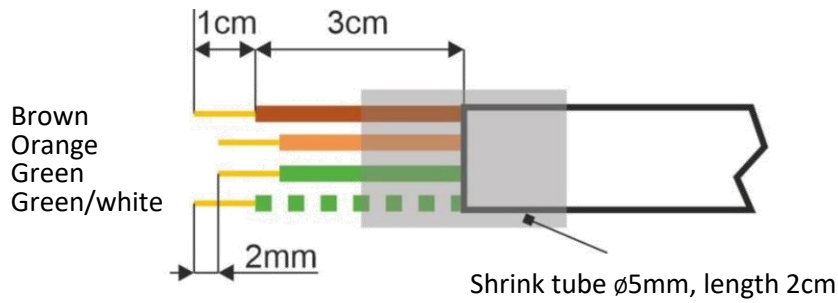

Fig. 16

- Open the controller box - the front of the box is connected to the rear by magnets, use reasonable force to open the box to avoid damaging the controller.

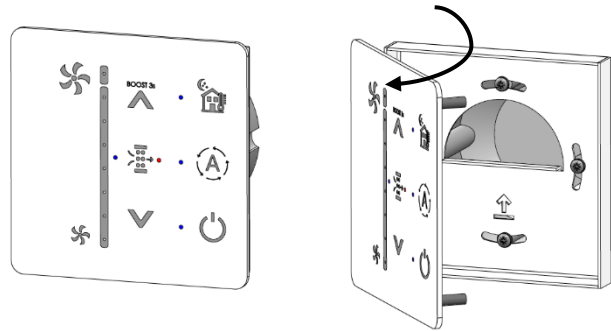

Fig. 17



Disconnect the already connected cables from the terminal block of the controller - according to item 3.2.3.4.

- Pull the prepared - stripped communication cable through the semicircular hole at the back of the controller and screw it to the wiring box (fasteners not included).

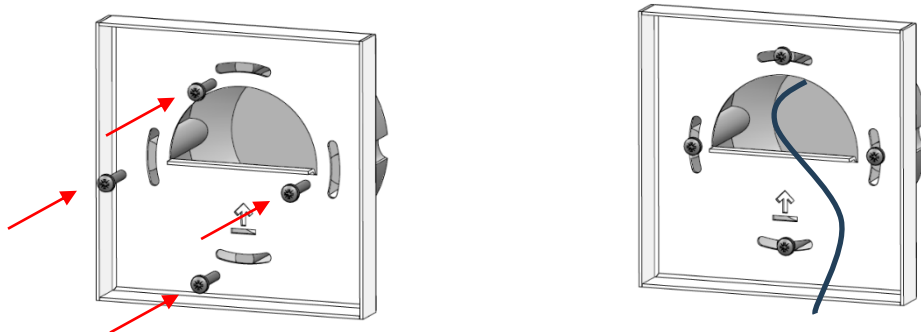

Fig. 18



Connect the prepared communication cable according to item 3.2.3.4 - the opposite procedure
Fit the front part of the controller onto the rear metal part

- Attach the other end of the communication cable - RJ45 8/8 connectors to the unit



Fig. 19



Connect the end of the communication cable to the unit according to item 3.2.3.3.

3.2.4. Connection of condensate drain - siphon

- The unit must always be fitted with a siphon (included in the delivery) with a connection to the sewer system.
- Always check the watering of the siphon and the condensate drainage before starting up for the first time or after shutting down the unit (the unit has been switched off for a long time).
- The unit is equipped with a condensate drain for each approved position and version (right/left). There are a total of 3 condensate drains on the unit for each version. The outlets are plugged as standard.

3.2.4.1. Condensate drains right-hand version of the unit – switch in position “R” – factory setting

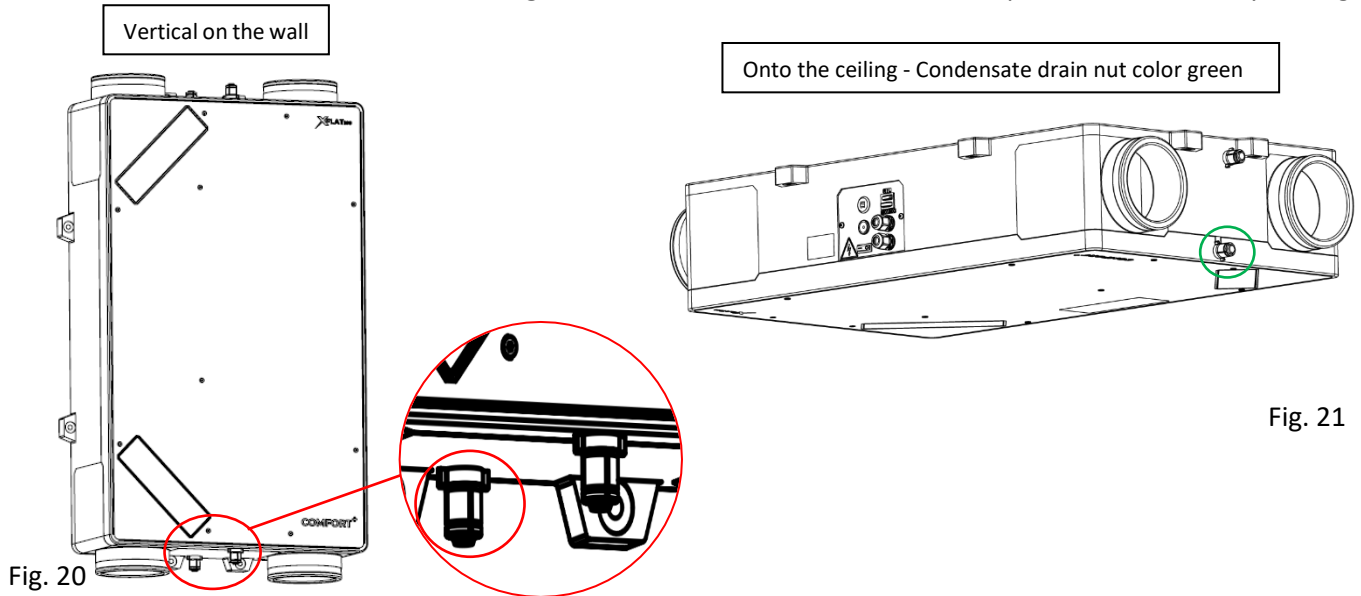

3.2.4.2. Condensate drain left-hand version of the unit - switch in position "L"

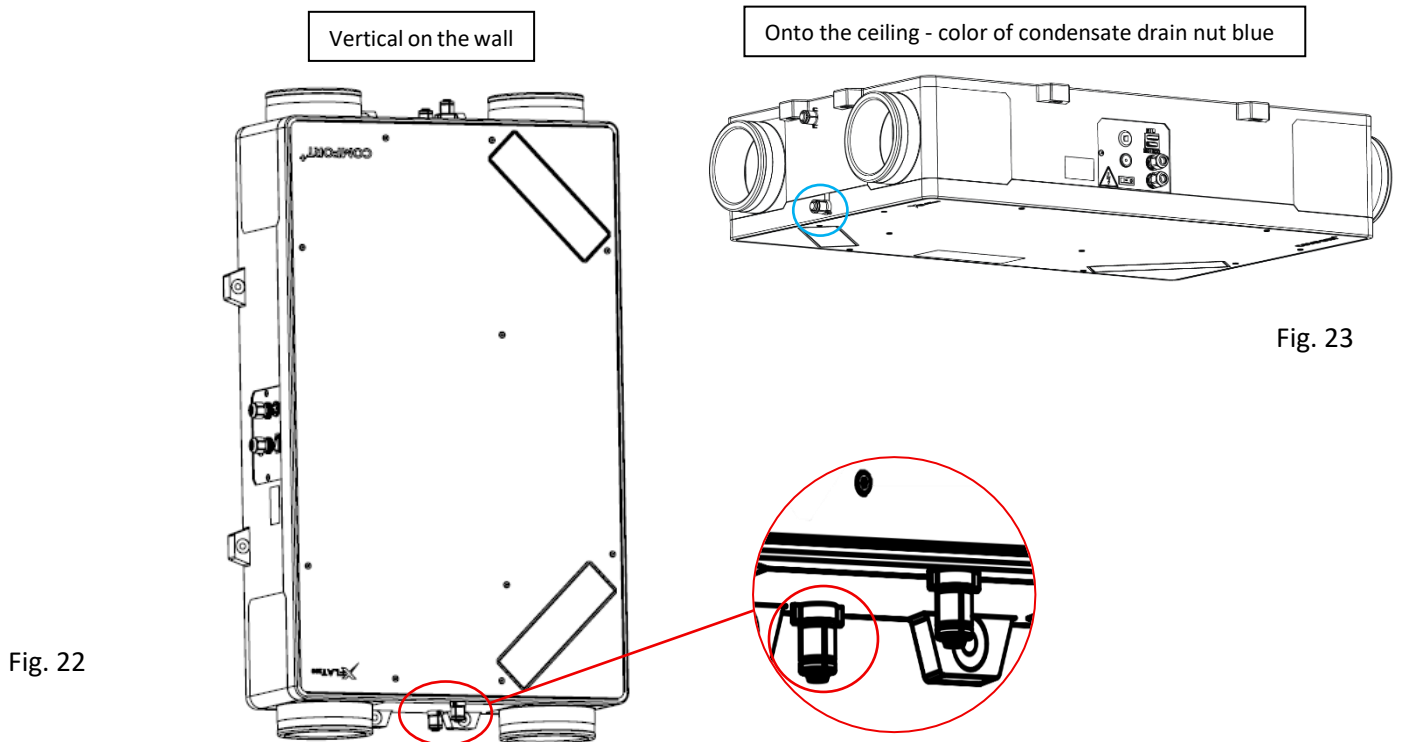

- The siphon must always be watered, well connected and sealed to the unit drain, otherwise there is a risk of condensate not draining from the unit and thus condensate accumulating in the unit with a possible overflow of the condensate tray. This can subsequently lead to property damage.

3.2.4.3. Connecting the condensate drain to the siphon



Select the appropriate condensate outlet according to the assembly position and the unit version. Correct determination of the condensate outlet should be carried out according to items 3.2.4.1., 3.2.4.2.

- Cut the end of the condensate throat 5 mm long

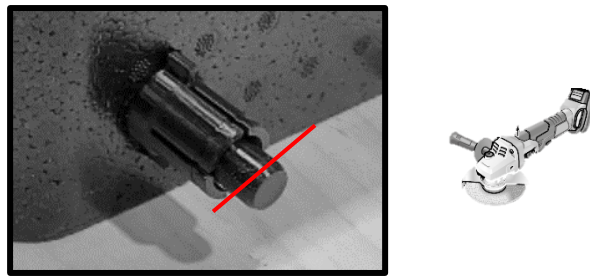
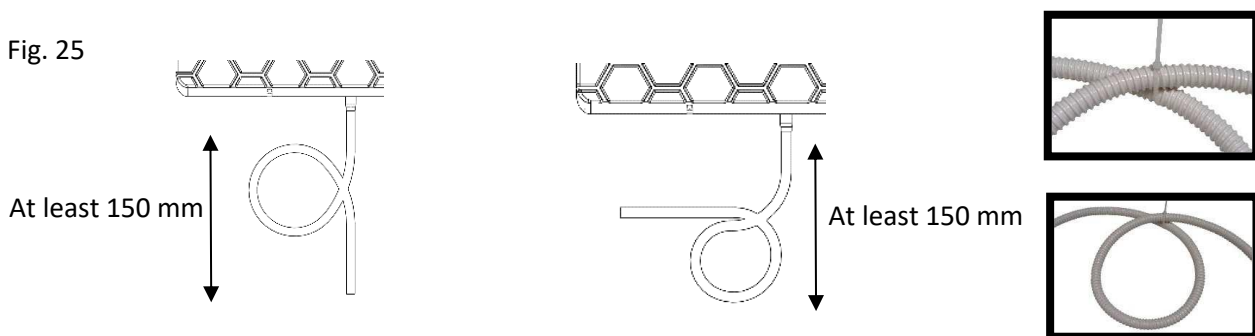

Fig. 24

- Remove the PVC siphon hose \varnothing 18/14 - 2 m and 2 pcs of 2.5x120 mm tie strap from the unit package
- Approximately halfway along the siphon hose, create a 150mm diameter loop.
- Secure the loop with 1 piece of tie strap, against arbitrary movement, but at the same time so as not to deform (break) the siphon hose

Fig. 25



- **Pay particular attention to maintaining a loop diameter of 150 mm and using adequate force when tightening the tie strap. If these requirements are not met, there is a risk of condensate not draining from the unit and thus condensate accumulating in the unit with a possible overflow of the condensate pan. This can subsequently lead to damage to the user's property and health.**
- Water the siphon - pour water into the siphon from the drain connection side of the unit until water flows out the other side of the siphon.
- Fit the fabricated siphon to the main drain
- Orient the formed siphon loop so that it functions as a water trap.

Fig. 26

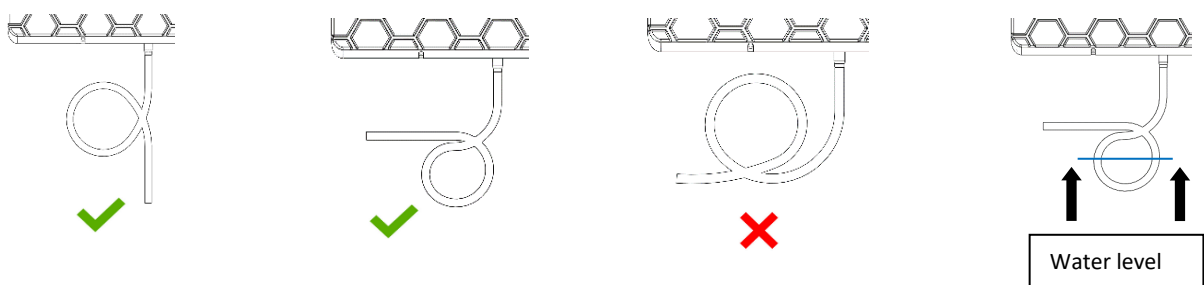

- **When creating a bend - elbow on the siphon hose, make sure to keep the correct bend radius of the hose to avoid "breaking" the hose and consequently choking the hose and preventing condensate drainage.**
- Secure the formed siphon with a second 2.5 x 120 mm tie strap (included) to the main drain located on the unit.

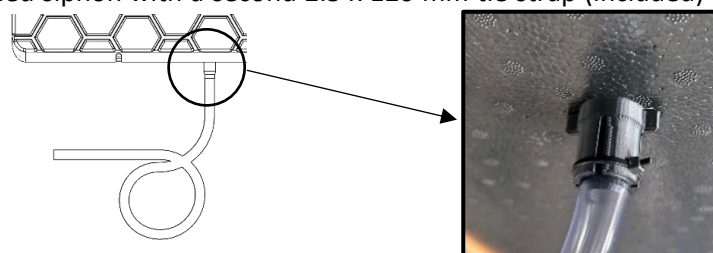

Fig. 27

- Adjust the other end of the siphon hose in length and connect - secure into the sewer system, keeping the minimum height difference between the siphon hose and the sewer connection.

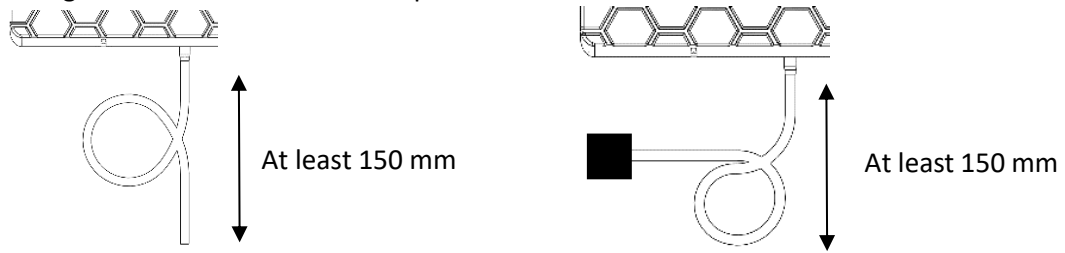

Fig. 28



- **Extension of the siphon hose is only permissible beyond the hose loop created. Extend with a hose of the same or larger diameter using a hose connector. Always ensure the smallest possible reduction of the inner diameter with the hose coupling.**

3.2.5. Connecting the air duct to the unit

- To connect the air duct to the unit, use the four spigots located on the outline of the unit
- You can use both 130 mm inner throat diameter and 160 mm outer throat diameter to connect the pipe.
- The unit necks allow the connection of pipes both in the axis of the unit (factory setting) and perpendicular to the unit - so called MULTIFLEX.
 - o Turning the throat perpendicular to the unit significantly reduces the building requirements at the assembly site
 - o Every throat can be turned separately, regardless of the number of throats in the axis and the number of throats perpendicular to the unit
 - o Turning the throats perpendicular to the unit has no effect on the flow rate or the reduction of external pressure drop

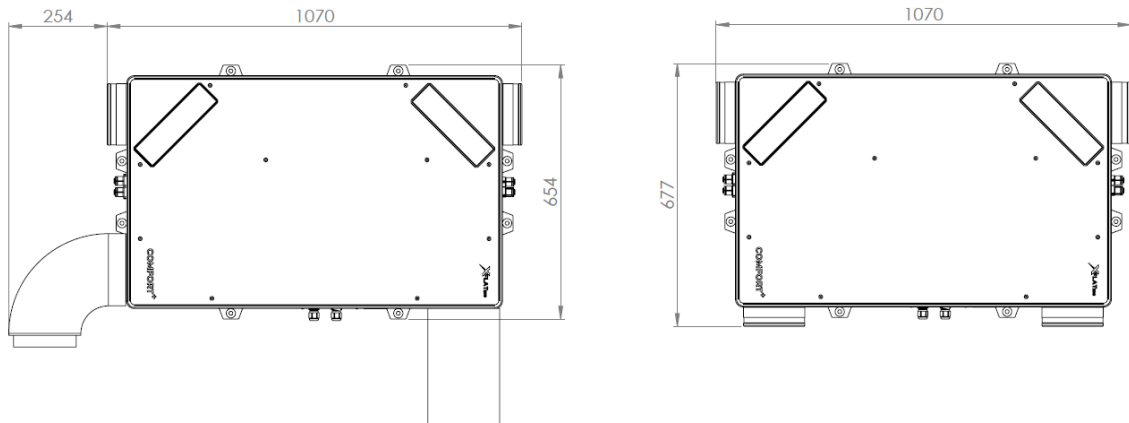

Fig. 29

- To turn the throat perpendicular to the unit, proceed as follows:

1.	Unscrew the 10x M6x25 bolt on the lid	2.	Remove the lid - gradually around the perimeter	3.	Pull out the throat you wish to turn
-----------	---------------------------------------	-----------	---	-----------	--------------------------------------

Fig. 30

4. Turn the throat perpendicular and push it into the groove

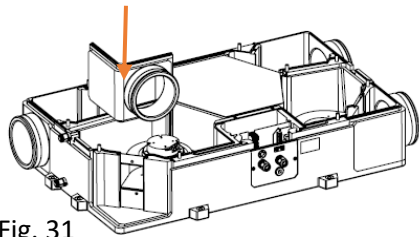
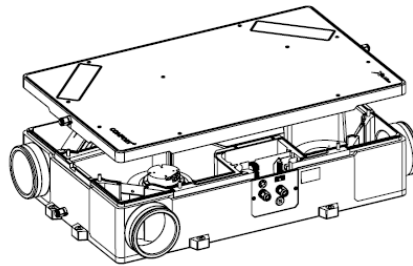

Fig. 31

- Push the pipe all the way onto the throat
- Seal the joints with aluminium tape or connecting sleeves to prevent vibration transmission.
- Insulate the connected pipe with thermal insulation material (rock wool, butyl rubber, etc...)
- Pull the pipe insulation all the way through the throat to the unit and secure against arbitrary movement. This prevents the formation of a thermal bridge at the connection point.

5. Put on the lid - push gradually around the perimeter of the lid



6. Secure the lid with 10x M6x30 bolts.

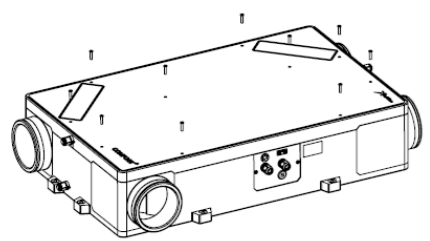
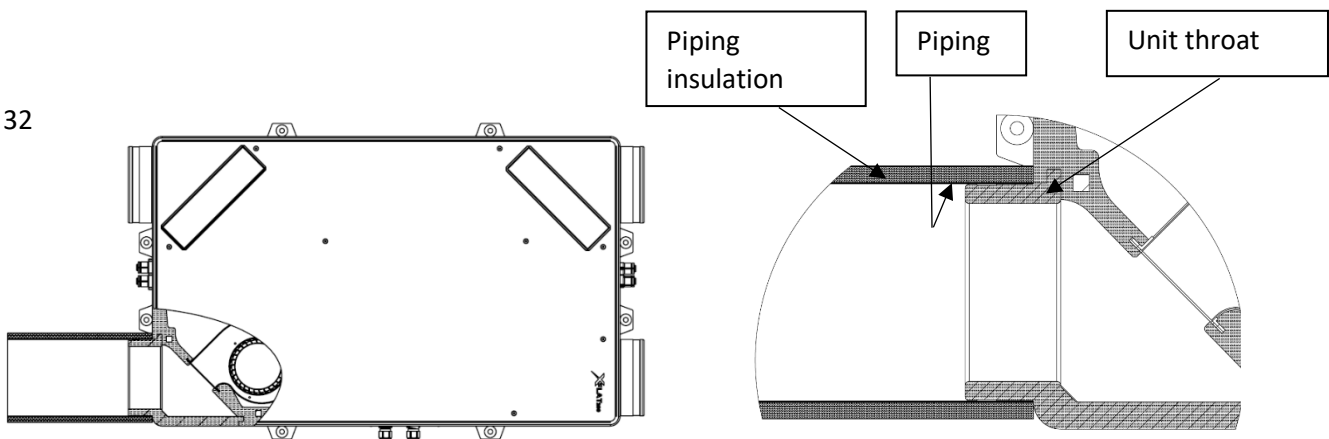

Fig. 32



- All the piping that is connected to the unit must be sufficiently sealed to prevent unwanted leaks and subsequent problems such as condensation.

3.3. Electrical Assembly – Connection to the Mains

3.3.1. General Information – Safety



- Before starting all the assembly works, make sure that the wiring box or mains power outlet that you want to use to connect the unit is equipped with a protective (green-yellow) conductor or contact (pin).
- If you use a mains plug to connect the unit, it must always remain accessible so that the unit can be safely disconnected from the mains in the event of danger.



- Check that the power supply meets the requirements for power supply of the unit (voltage, current, frequency, etc.) specified on the unit's serial plate. Section 3.3.3. Displaying the Electrical Parameters.
- The relevant current circuit must be protected in the electric power distribution system by the maximum of 16 A.
- The electrical cable to be connected to the mains must not be broken.
- Local electrical regulations must always be respected.
- Electrical connection of the unit to the mains may only be carried out by persons qualified for this activity with a valid authorisation and knowledge of relevant standards and directives in the country.
- Before starting any assembly work, it is necessary to switch off the power supply. During the assembly, the switch must be secured against being switched on again by an unauthorised person. The switch must have the minimum contact spacing of 3 mm.
- A two-pole disconnecting means (circuit breaker) must be connected to the unit's supply.
- It is forbidden to interfere in any way with the internal connection of the unit, unauthorised interventions in the unit may lead to loss of warranty servicing claims

- This unit belongs to the product group with type Y connection. If the supply cord is damaged, it must be replaced by the manufacturer, its service centre, or similarly qualified person to avoid dangerous situations.
- The unit is classified as protection class 1 category of appliances in terms of protection against electric shock.
- The unit supply voltage of 1~230V/50-60Hz may not be modified in any way; otherwise, there is a risk of damaging the electrical elements of the unit.

3.3.2. Connection to Mains

- The unit is equipped with a separate strand-type supply cable (stranded wire). The stripping of the cables to the individual conductors is 50 mm. The individual conductors are equipped with crimped terminals.
- The power supply cable length of 1 m may be shortened by a qualified person as needed.
- The individual conductors are colour-coded
 - o brown/black – Phase conductor – L
 - o blue – Neutral conductor – N
 - o green-yellow – Protective conductor – PE

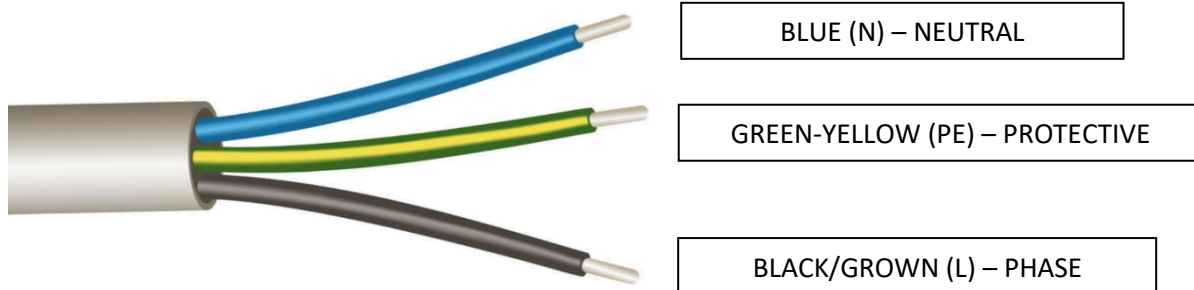

Fig. 33

3.3.2.1. Connection of the Unit to the Wiring Box

- The power supply cable is prepared by the manufacturer for connection to the wiring box.
- Use adequate connecting elements (e.g. terminal plates, spring terminals, etc.) to connect the power supply cable to the mains.
- **The assembly of the power supply cable in the wiring box and connection to the mains must be carried out by a qualified person who has a valid authorisation for this activity and knowledge of the relevant standards and directives in the given country.**



3.3.2.2. Connecting the Unit to the Electrical Outlet

- The supply cable can be equipped with a fork with a protective conductor (pin) – not included in the delivery.
- **Connection – assembly of a plug on the supply cable must be performed by a qualified person who has a valid authorisation for this activity and knowledge of the relevant standards and directives in the given country.**



3.3.2.3. Recommendations for protecting the Xflat 200 unit

- It is recommended to protect the unit with a 1-phase (1x230V) circuit-breaker with the current value of 6 A. The correct value of the protection element must be designed by an electrical expert taking into account the conditions at the assembly site, e.g.: (cable length)

3.3.3. Display of Electrical Parameters

- All of the unit's electrical parameters are provided on the serial plate

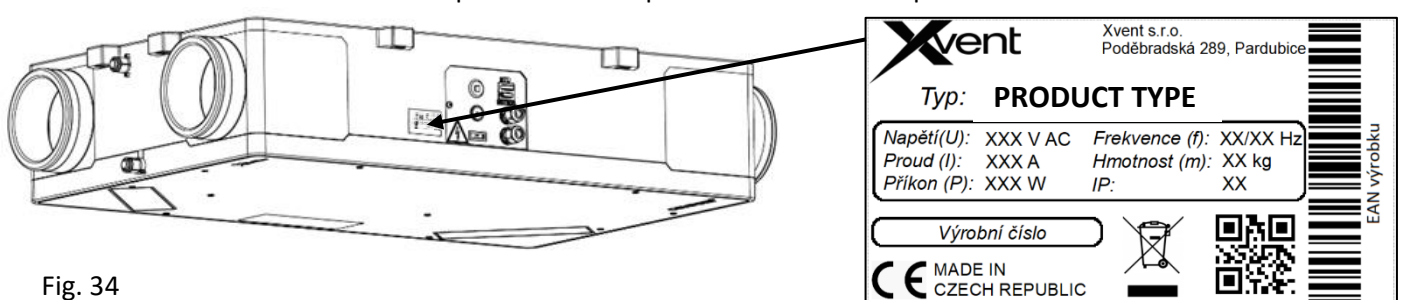

Fig. 34

4. Regulation

4.1. General Information – Safety

- For proper operation of the unit (in the manual regime) nothing else needs to be connected to it. It is, therefore, ready for its immediate use after assembly. To operate in the automatic regime, you must connect the CO2 (NL-ECO-CO2) or RH (NL-ECO-RH) air quality sensor accessory.



- **Always turn off the unit at the control panel and main switch before entering the control in any way (position 15).**

4.2. Setting up the unit - connecting accessories

4.2.1. Regulation Approach

- Set the unit and its electrical accessories in the regulation box.
 - o Loosen the 2x flat head screw 5x20 that secures the cover plate of the regulation box.
 - o Loosen the grommet nuts from the supply and communication cable
 - o Remove the cover plate of the regulation box
 - o Connect the necessary electrical accessories
 - o Spring terminals with manual wire locking are used to connect the individual components. A strand-type conductor (stranded wire) and a solid conductor (wire) in the cross-section range from 0.5 to 1.5 mm² can be installed in the terminals.
 - o Before inserting the conductor into the terminals, first press the locking orange push-button. Then retract the conductor, release the lock, and slightly pull it out of the terminal to verify that the conductor is properly secured. If the conductor needs to be removed from the terminal, the procedure is the same.

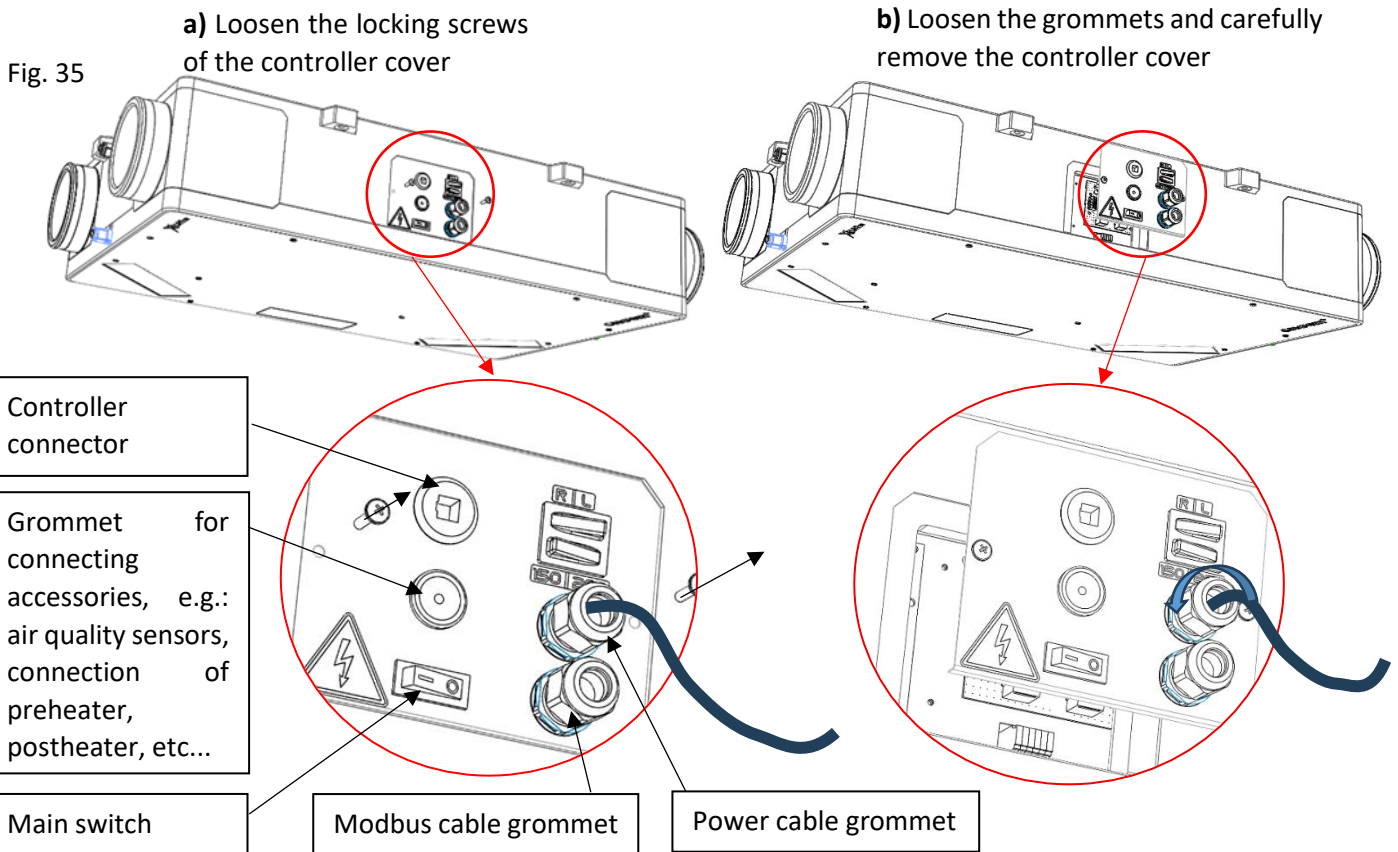

- Use the membrane multi-pass for connecting the accessories. Always select the individual grommets according to the size of the cable you will use for connecting accessories.



- The communication cable for connection of the unit to the higher-level Modbus system is connected directly to the unit control to the main control board - RJ connector with a plug and BMS sticker see Chapter 4.2.4.6



- The optimum cross-section of the conductor must be selected according to the actual length of the conductor route; however, the maximum diameter of the conductor may be 1.5 mm².
- All the conductors shall be connected to terminals with adequate force to prevent damage to them or damage to the electrical board. The insulation stripping on the individual conductors must be 10 mm. For strand conductors, the terminal must be crimped (socket).



- The regulation is normally integrated into the body of the unit and in any case must not be handled in any other way than as specified in this manual.

4.2.2. Settings - switching the right left unit - EXT4



- The unit regulation allows switching between right and left-hand versions
- The orientation of the throats for the right or left version of the unit is dealt with in separate Chapter 3.1.5.
- The version setting is done by switching the switch (position 18) to the following position:
 - o Position "R" – right version – factory setting
 - o Position "L" – left version

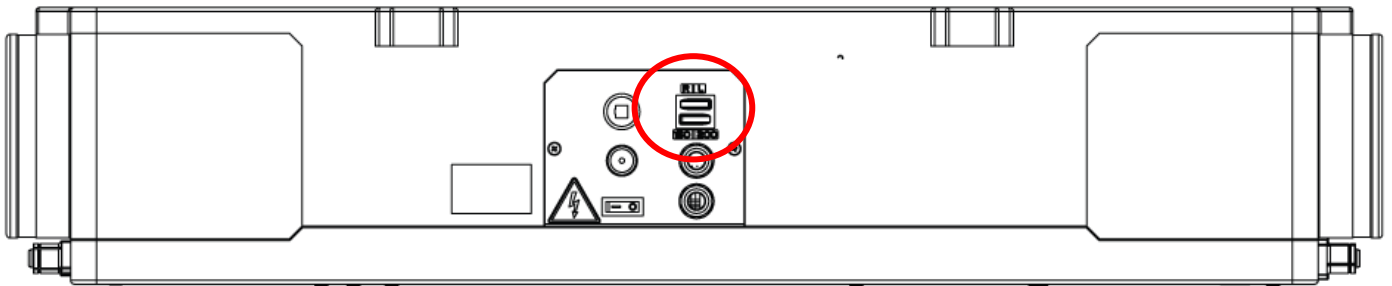

Right version - factory settings

Left version



Obr. 36

4.2.3. Settings – switching the nominal output of the unit

- The unit has a switching of the nominal air output of 150m³/h and 200m³/h
- The required air output is set by switching the switch (position 19) to the following position:
 - o Position "150" – nominal air output 150m³/h
 - o Position "200" – nominal air output 200m³/h – factory setting

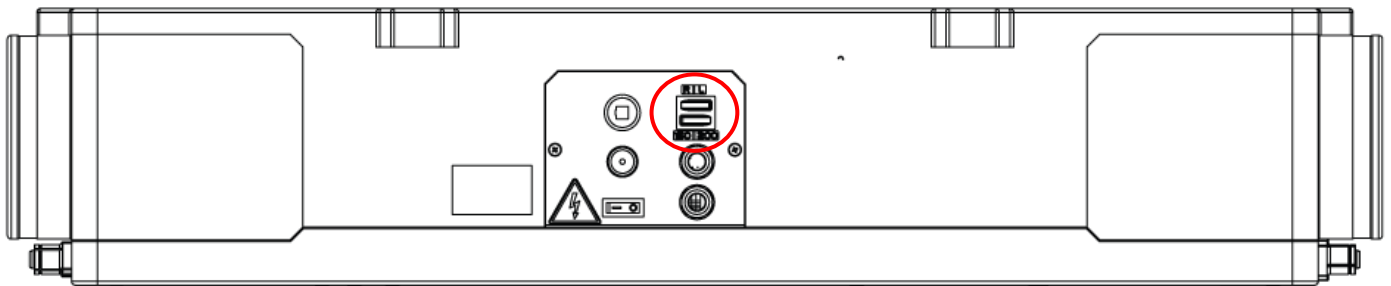

Nominal air flow 150 m³/h

Nominal air flow 200m³/h – factory setting



Fig. 37

4.2.4. Connecting Electrical Accessories

- Location of terminals in the control unit for connection of electrical accessories

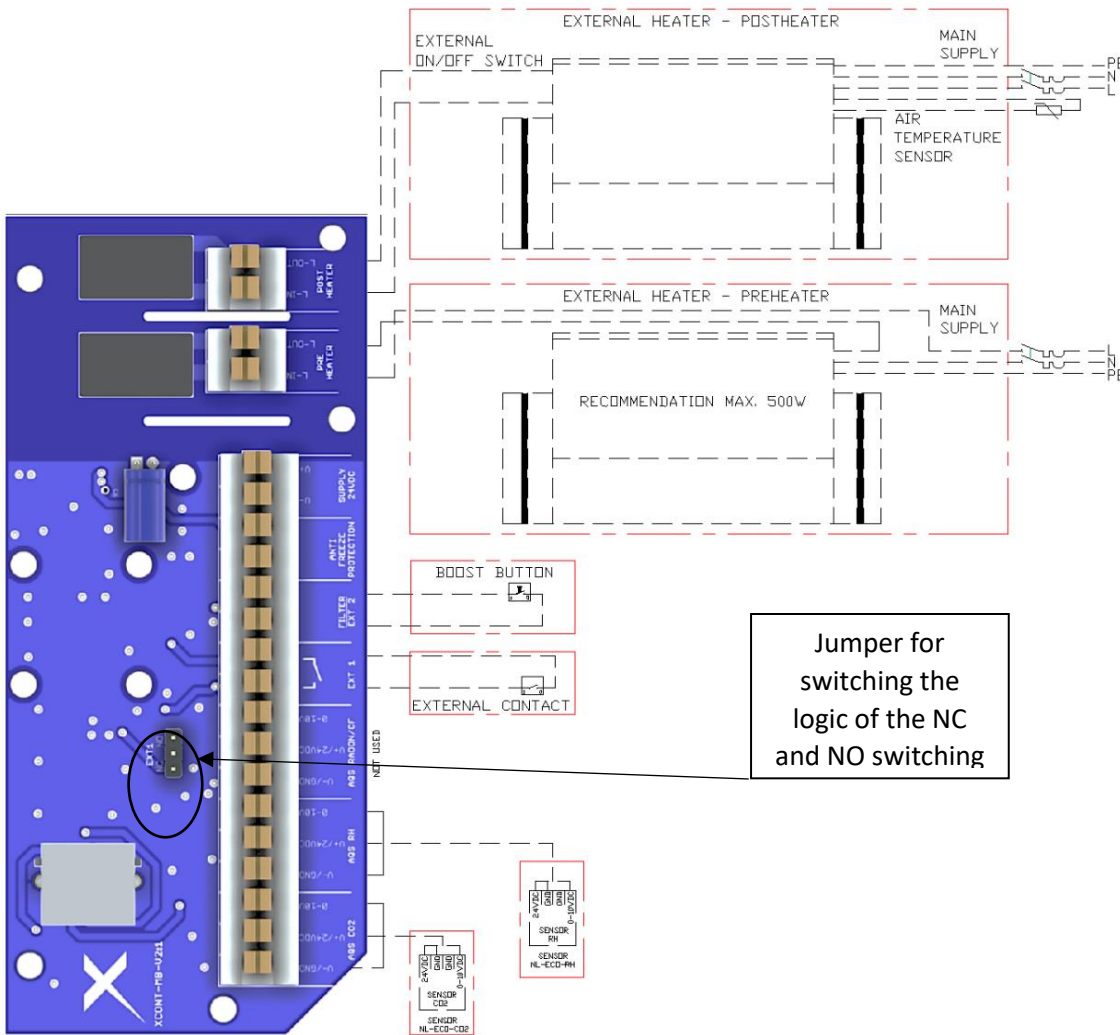

Fig. 38

4.2.4.1. Connection of the CO2 (NL-ECO-CO2) and RH (NL-ECO-RH) sensors - AQS sensors (AQS CO2; AQS RH)

- It is possible to connect 2x AQS sensors (1xCO₂ and 1xRH) to the unit, which are used to measure the CO₂ and RH concentration in the air at the place where the sensors are installed. Thanks to the sensors, it is possible to operate the automatic regime of the unit, which automatically controls the operation and air output of the unit according to the actual demand in the space where the sensors are installed. This method of control is also the most efficient in terms of operating economy - it is ventilated only as the need arises.

Technical parameters of the AQS sensors for connection to the unit

- o 24 VDC sensor power supply
- o 0- 10VDC analog output
- o Max. sensor power consumption 5 W
- o Analog sensor input resistance 100kΩ
- o

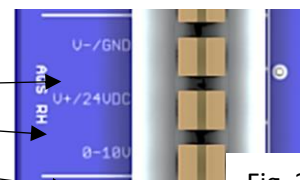

Fig. 39



- **The power supply GND is shared with the GND of the analog input. If the connection is not carried out correctly, there is a risk of destroying the control board**

4.2.4.2. Connecting multiple AQS sensors

- Connecting more sensors than 1x CO₂ and 1x RH is possible using the “PRO-SUM-08” accessory.
- With this accessory, you can connect up to 8 sensors of one variable to one input on the control board (1 pc “PRO-SUM-08” = 8 pcs CO₂; 1 pc “PRO-SUM-08” = 8 pcs RH)
- Only sensors from one variable must be connected to one “PRO-SUM-08” accessory.

4.2.4.3. Unit functionality after connection of the AQS sensors

- If you wish to control the unit using the AQS sensors, activate the automatic regime function – push-button 4.
- The unit responds by continually controlling the need for real-time ventilation triggered by sensors:
 - o When the concentration of the monitored substances is reached, ventilation shall be switched on with the minimum flow rate:
 - CO₂ – 800 ppm,
 - RH – 65%.
 - o If the reduction of the concentration of the monitored substances in the room is not achieved, the unit controller increases the flow up to the maximum flow value set by the user.
 - o The unit controller will start to decrease the flow rate continuously again while reducing the concentration.
 - o The aim of the regulation – ventilation, is to find the ideal degree of ventilation (flow rate) depending on the concentration of the monitored substance in the ventilation room. For this reason, the unit may ventilate for a long time until it reaches safe limits of concentration or complete ventilation of the substance being monitored.
 - o When the concentration is reduced to a specified value, ventilation is switched off and the unit is switched to the standby regime:
 - CO₂ – 700 ppm,
 - RH – 60%.
- If there is a requirement for ventilation from several sensors, the controller gives priority to a sensor with a higher ventilation requirement.
- The AQS sensor ventilation switching level settings can be changed in the parent BMS (Modbus RTU).

4.2.4.4. External Contact Connection – (EXT 1)

- Unit control allows for connection of external contact for remote switching on and off of the unit (remote control ON/OFF).
- External contact is designed as potential-free and can be switched on e.g.:
 - o Using magnetic door contact (a contact used in security systems). The contact can be installed, for example, on the window. When the window is opened, the unit stops, and then restarts when the window is closed.
 - o Using a remote switch. In the facility, the electrical appliances are switched off by one push-button (the total stop system). The unit may be included in this system via this contact.
 - o Using a time relay. The unit may be switched on/off by a time relay located in the switchboard.

4.2.4.4.1. Technical Parameters of External Contact EXT1

- o Switching voltage 24 VDC / 5 mA.
- The contact may change the switching logic by connecting the jumper to the NC or NO switching logic (factory settings).

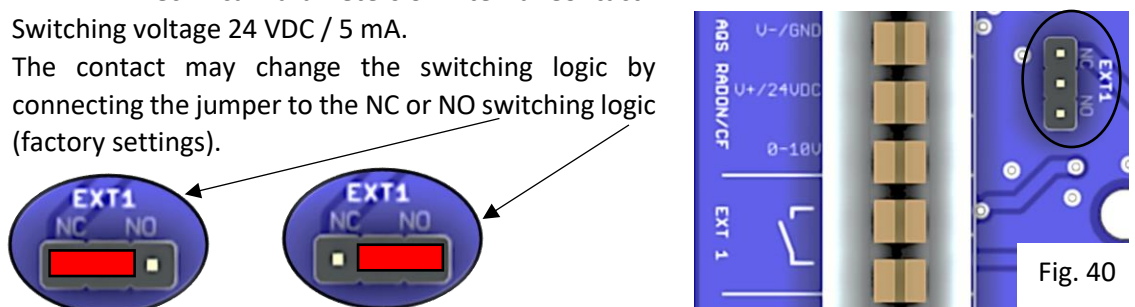

4.2.4.4.2. Functionality of the Unit when Controlled by External Contact EXT1

- External contact switches the unit on and off (the same functionality as on the ON/OFF push-button controller) with logical termination or activation of all running processes at the time of switching off, on.
- If the unit is switched on/off by an external contact, it can be switched off/on by the controller on the unit.
- An example of the external contact functioning – a timer is used as an external contact:
 - o EXT1 activates the unit at the given time (in the morning) – the unit operates according to the user settings,
 - o during operation, the unit is switched off by the controller on the unit – the unit switches off,
 - o EXT1 switches the unit off at a given time (in the evening) – the unit remains switched off,
 - o EXT1 activates the unit at the given time (the following morning) – the unit works according to the user settings.



- **If you want to prevent control of the unit by unauthorised persons and you want to control the unit by external contact, we recommend that after setting the unit parameters, you activate a child lock, which prevents access to unauthorised persons (the unit cannot be switched off on the unit controller). This ensures that the unit is switched on/off only via an external switch.**

4.2.4.5. External Contact Connection – BOOST (EXT2/FILTER)

- The unit regulation allows the connection of an external push-button (flap switch with automatic flap return - e.g.: bell push-button with return spring) to start the shock ventilation regime for a set period of time - BOOST (hereinafter referred to as BOOST)
- The BOOST regime is designed for shock ventilation for a certain period of time in rooms with an immediate need for ventilation e.g.: bathroom, toilet etc..
- The ongoing BOOST regime is signalled on the unit controller by flashing the 8LED diode - see Chapter 5.4.2.



4.2.4.5.1. Technical Parameters of External Contact - BOOST

- The external contact is designed as potential-free
- Switched voltage 24 VDC / 5 mA.

4.2.4.5.2. BOOST regime functionality

- When the push-button (damper switch with automatic damper return) is pressed, the BOOST regime is activated
 - o The BOOST regime is activated and the unit starts at the set air output and running time.
 - o After the set BOOST regime running time is over, the unit returns to its previous regime.
- If you wish to exit BOOST regime before the set run time.
 - o Hold the push-button for approx. 2 s.
 - o The BOOST regime is automatically ended, and the unit returns to its previous regime.
- BOOST regime factory setting:
 - o Air output in the BOOST regime - max air output of the unit
 - o Duration of the BOOST regime - 1 min



Fig. 41



- The air output and duration of the BOOST regime is adjustable in the customer menu, see Chapter 5.5.
- If necessary, it is also possible to start the BOOST regime directly at the unit controller, see Chapter 5.4.2.

4.2.4.6. Connecting the unit to a higher-level BMS or web application using the Modbus RTU protocol

- The unit is equipped with the possibility of connecting to the parent BMS system (hereinafter referred to as BMS) or to the control using a web application and wifi module (hereinafter referred to as WifiModule - separate accessory).
- The connection of the unit to the parent BMS must be carried out by a competent, knowledgeable person.

- Connection of the WifiModule and subsequent control of the web application must be performed by a person with at least basic knowledge of PC technology and web browsers.
- Connection of the unit to the BMS and to the WifiModule must be made using a UTP cable with RJ45 8/8 connectors. The RJ connectors on the UTP cable must be wired as a direct connection (both connectors are wired the same way)
- Use the "XCONT-HUB" accessory to connect multiple units and then control them using the BMS. Addressed by the separate "XCONT-HUB" accessory manual
- Pull the connection cable into the control through the large grommet in the control housing - see item 4.2.1.
- Plug the connection cable into the RJ connector marked BMS-RS485



View of the PCB in the unit regulation - connection of the connector for control by BMS-RS485

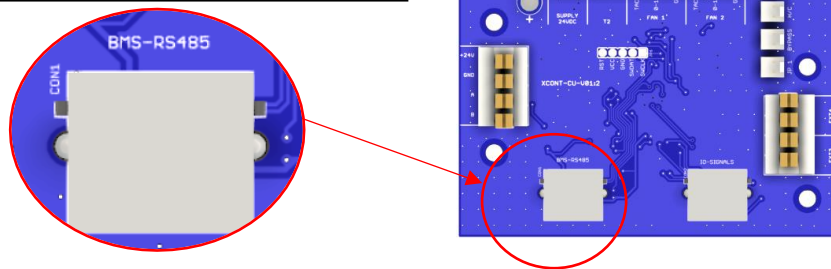

Fig. 42



- Communication of the unit with the parent BMS system is solved by the Modbus RTU communication protocol. Protocol description is addressed in the separate user manual "D-502-xxx-Vxxx-xxx-MN-CENTRAL-MODBUS"

4.2.4.7. Connecting the external electric preheater - (PREHEATER)

- The unit can be connected to an external electric heater – preheater (accessory EK-PH-160-06-1f) with the maximum output of 1,500 W, voltage 1x230 V.
- Recommended heater power min. 400 W to 600 W
- The unit switches only the supply phase - potential (L-IN) to the heater (L-OUT).
- The logic of the preheat switching is subordinated to the temperature on the antifreeze sensor.
- If the preheating is not sufficient to defrost the heat exchanger, additional antifreeze logic is triggered in addition to the activated preheating.
- The unit's controller cannot detect the presence of an external preheater, so it assumes it is always connected. In case the external preheating is not connected, the heat exchanger is protected against freezing by other frost protection logic.
- We recommend using the heater without regulation with direct connection to the regulation unit with safety thermostats. The heater control is replaced by a unit control with ON/OFF switching and expansion type (100% power / 0% power).
- For trouble-free and long-lasting operation of the external preheater, we recommend using a box in front of the filter to catch coarse dirt.
- **The supply wiring for the preheater must be a separate supply, including the switched phase controlled by the unit, under no circumstances must the preheater be powered from the unit.**



Fig. 43



- **Sample wiring diagram:**

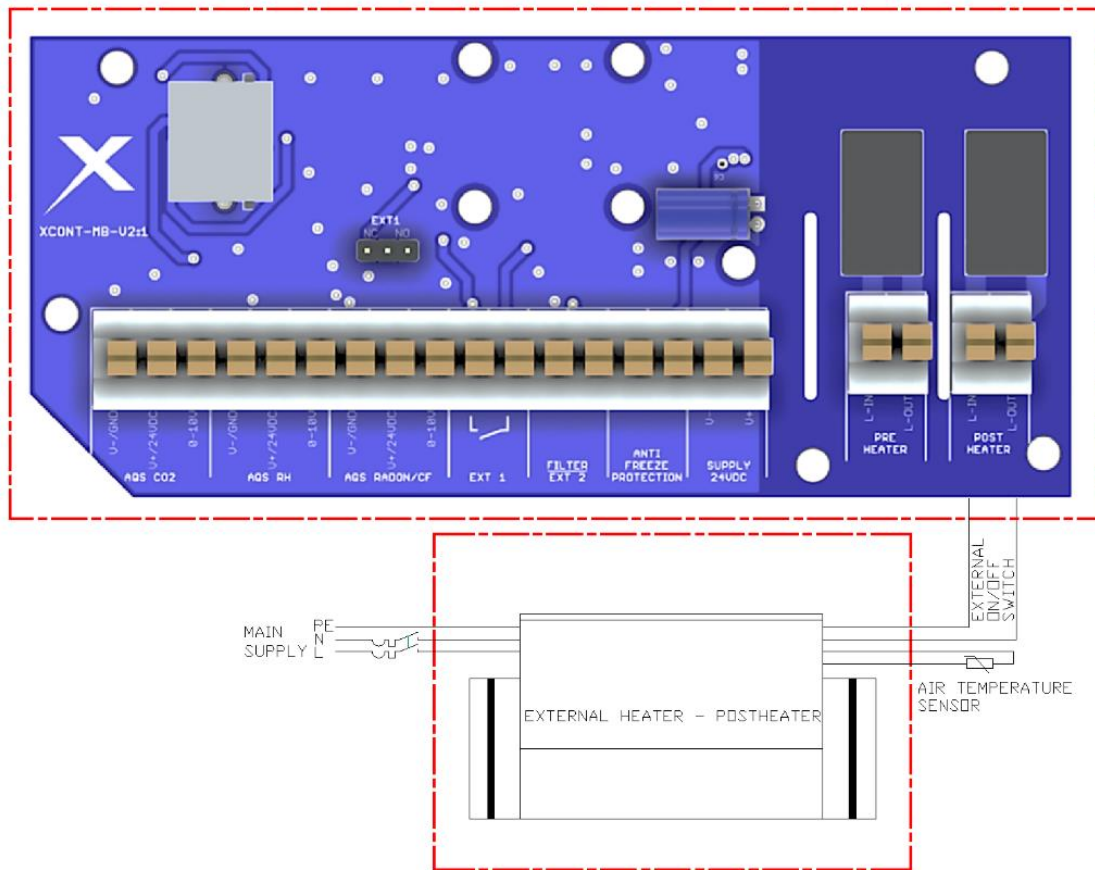

Fig. 44



- **Install the heater - preheater according to the heater manufacturer's instructions, e.g.: flow direction, distance from the unit, heater position, distance of temperature sensor from the heater, etc..**
 - **If the heater manufacturer requires a minimum piping velocity for proper heater operation, this must be addressed by a separate component (e.g.: differential pressure sensor). Under no circumstances shall the unit be used for this purpose.**
- In no event shall the manufacturer of the unit be liable for improper assembly, malfunction or damage caused by the heater.**

4.2.4.8. Connecting an external electric postheater - (POSTHEATER)

- The unit can be connected to an external electric heater (hereafter the postheater only) - (accessory EK-AH-160-0,6-1f)
- The max power of the postheater is 1,500 W, voltage 1x230 V.
- The unit switches only the supply phase - potential (L-IN) to the postheater (L-OUT) with this logic:
 - o If the unit is ventilating the phase is switched - the potential is switched
 - o If the unit is stationary, the switched phase - potential is open
 - o If the unit is ventilating, but the ventilation request is terminated (AQS control - automatic regime).
 - The unit disconnects the switched phase
 - The power of the unit's fans is reduced to the minimum and the after-cooling regime runs for 3 min
 - The after-cooling regime is indicated by a flashing LED on the controller above the ON/OFF push-button
- The unit's control cannot detect the presence of an external heater, so it assumes it is always connected. The result is that whenever the fans are switched off (either by user request or AQS sensors), the after-cooling function is triggered.



Fig. 45

- We recommend using a heater with a channel sensor (for temperature control) and control via an external contact from the unit
- **The supply wiring for the postheater must be a separate supply, including the switched phase controlled by the unit, under no circumstances must the postheater be powered from the unit.**
- **Sample wiring diagram:**

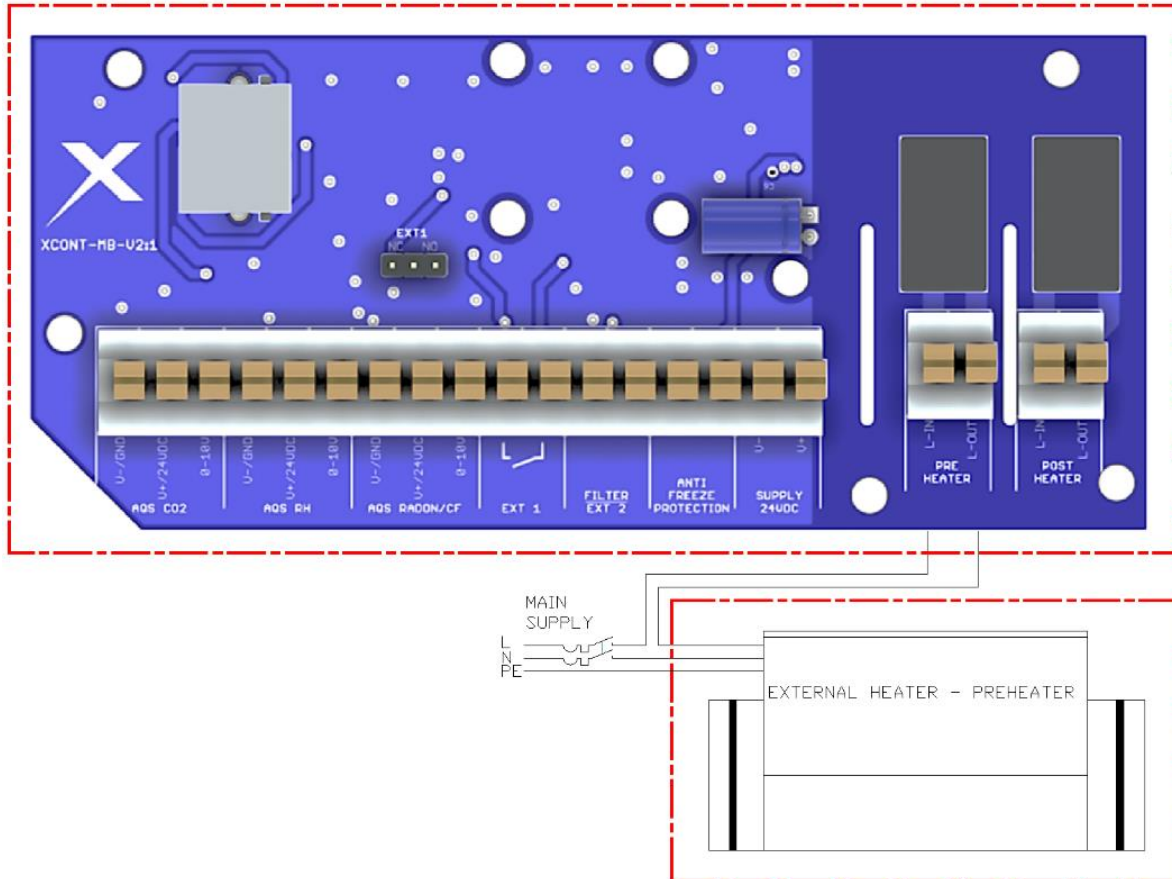

Fig. 46



- **Install the heater - reheater according to the heater manufacturer's instructions, e.g.: flow direction, distance from the unit, heater position, distance of temperature sensor from the heater, etc..**
- **If the heater manufacturer requires a minimum piping velocity for proper heater operation, this must be addressed by a separate component (e.g.: differential pressure sensor). Under no circumstances shall the unit be used for this purpose.**
- **In no event shall the manufacturer of the unit be liable for improper assembly, malfunction or damage caused by the heater.**

4.3. Block diagram of the Xflat 200 unit – Regulation COMFORT, COMFORT+

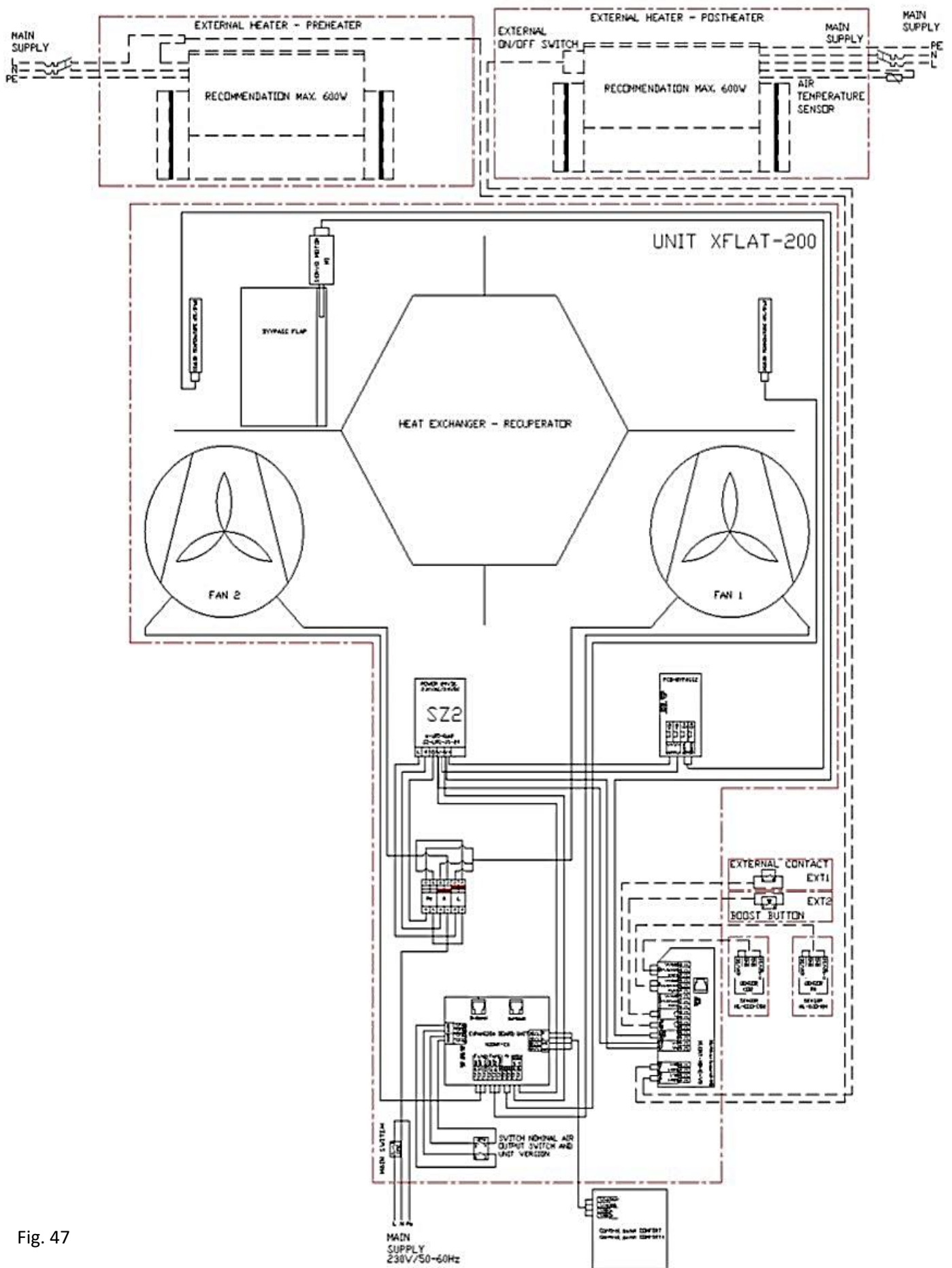

Fig. 47

5. Commissioning

5.1. Prior to the first start, check:



- That all the assembly works have been duly completed as indicated in Chapter 3,
- Whether the power supply cable of the unit is properly connected to the mains,
- Whether the connected electrical accessories are correctly wired,
- Whether the condensation trap is watered, and the condensate outlet is connected to the sewer system,
- Whether the unit contains clean filters.

5.2. Activation – Basic Unit Commissioning



- **The basic unit commissioning is used to verify the functionality of the unit after completion of the assembly.**

Further options and details on unit settings are provided in the following Sections.

1. Switch the main switch from position 0 (OFF) to position 1 (ON) and wait until:
 - All the LEDs on the controller flash 3 times.
 - All the status LEDs flash.
 - The LEDs stop flashing - controller is loaded - you can continue
 - The controller is loaded only when power is connected to the unit.

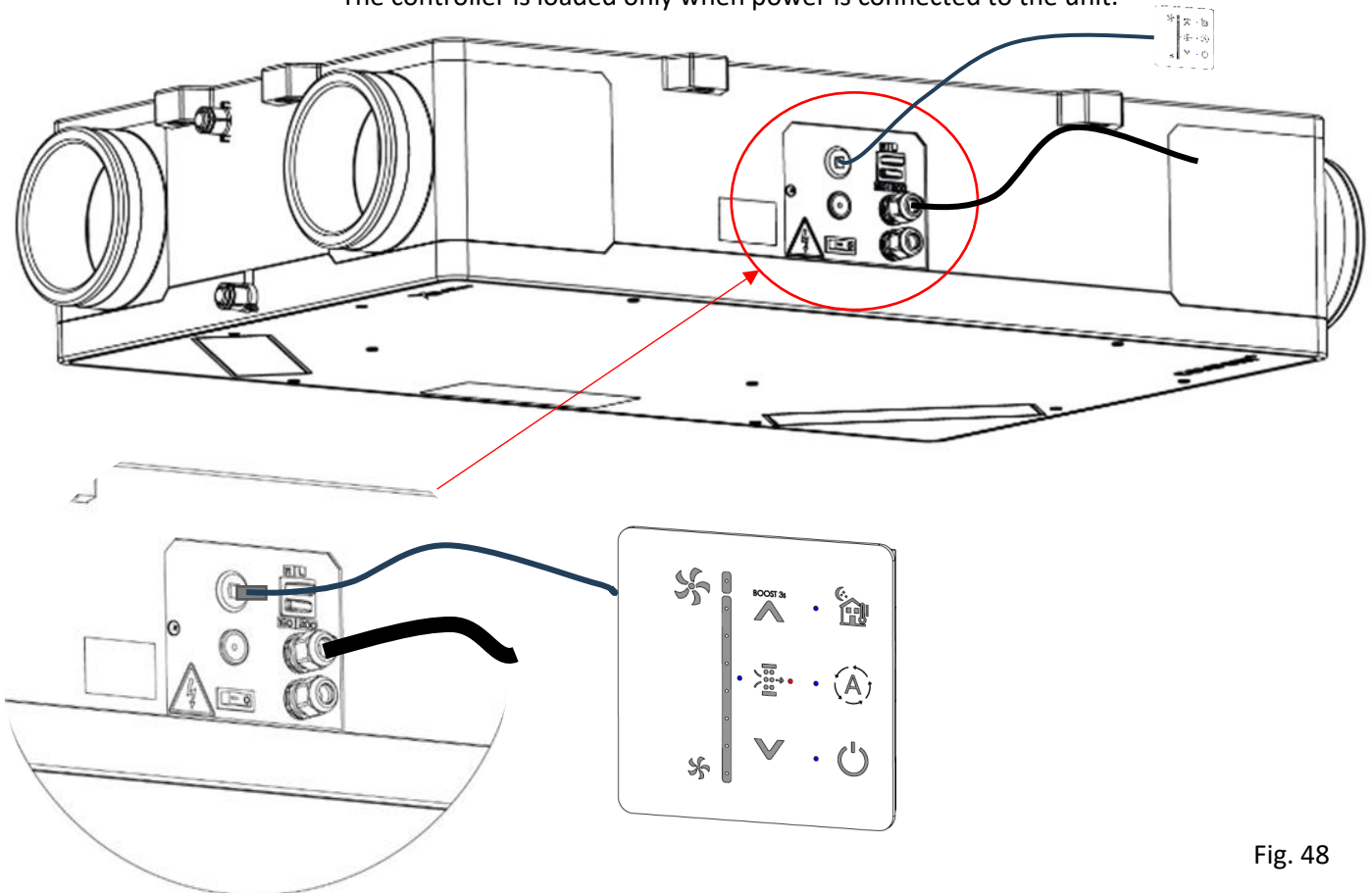

Fig. 48



2. Hold down the ON/OFF push-button for approx. 3 s until the blue status LED above it lights up. Unit is switched on
3. The unit is factory set to 4th ventilation level, which is used to verify the basic functionality of the unit.
4. Check the unit's operation - for example: by hearing,
5. The unit is operational.
6. Now, you can perform further unit settings according to your requirements.



If you have already connected the AQS air quality sensors when you first start the unit, the automatic regime LED will flash - sensor calibration is in progress (approx. 5 s). The fans can take up to 20 s to start up from their idle state.

5.3. Controller Operating Regimes

- The controller operates in 3 display regimes.

5.3.1. Sleep Regime – Regular Operating Regime

- Only the operating state is displayed – the unit is on and the LED on/off of the unit is on (push-button 2). The unit is fully functional, running according to user settings.

5.3.2. Control Regime – 1 click

- When any push-button is clicked, the active functions and settings of the unit (ventilation power) are displayed on the controller. The display is lit for approx. 4 s, then the controller returns to the sleep regime.
- The functions that can be started from this regime are listed in Table 17. Description of the Xflat 200 control functions.

5.3.3. Unit Setting Regime – 2 clicks

- The setting or activation of some functions is only possible from this regime.
- The setting regime is activated by clicking on the push-button, for which the function is to be changed. The plus and minus push-button is for activation - power setting ventilation (flashing LED in the fan pictogram)
- The functions that can be started from this regime are listed in Table 7. Description of the functions of the push-buttons and controls of the Xflat 200 units.

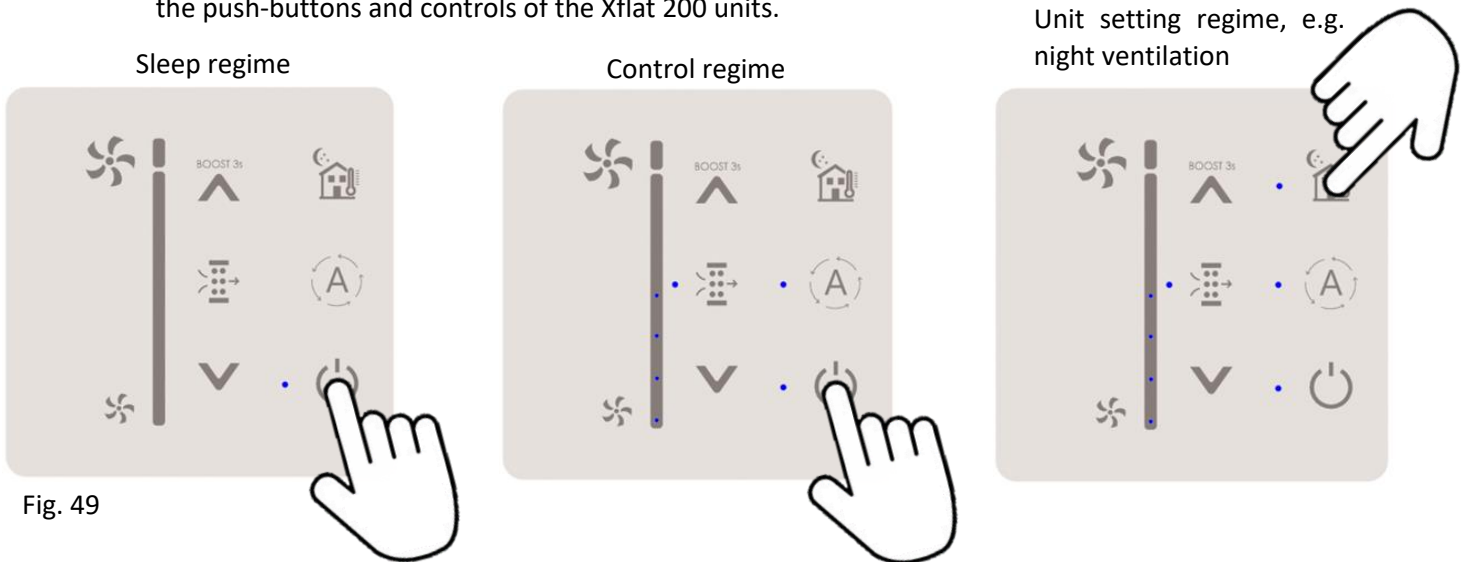

Fig. 49

5.4. Unit Control Method

5.4.1. Control Panel – Controller

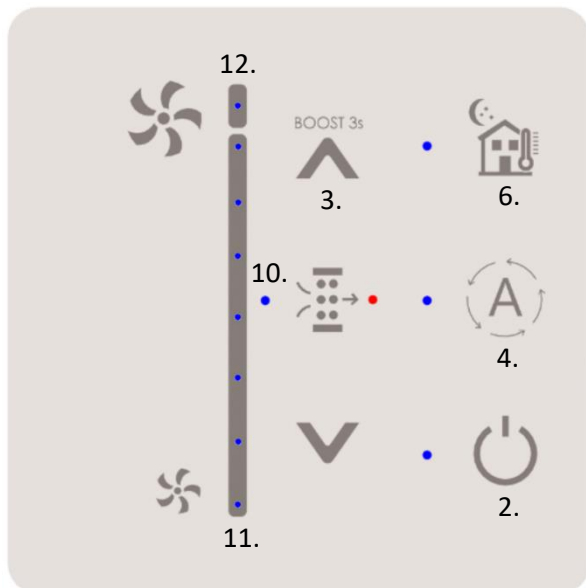



Fig. 50

5.4.2. Description of the functions of the push-buttons and regulation

Tab. 8

Control description number	Symbol	Button/Indication	Button description	Active in mode / number of			Function	Note
				Dormant 0x	Control 1x	Settings 2x		
1.		Button	Reduction of ventilation output	⊗	⊗	⊙	<ul style="list-style-type: none"> - Switches from the control regime to the ventilation output setting regime - Press the button to reduce the desired level by one step on the ventilation output setting scale 	
2.		Button	Unit switching on (signalling)/switching off ON/OFF	⊙	⊙	⊗	<ul style="list-style-type: none"> - By holding the button for 3 seconds, switch the unit on (LED lights up) or off - if the LED flashes after the unit is switched off, the heating is cooled down. Once finished, it will turn off 	
3.		Toggle function button	Start of intensive ventilation - BOOST	⊗	⊙	⊗	<ul style="list-style-type: none"> - Press the button for 3sec to start intensive ventilation for 1 min. To switch it off before 10 minutes pass, press the button again for 3 seconds, and the ventilation returns to the pre-start regime. 	<ul style="list-style-type: none"> - The function start indication is flashing diode 12. - The air output for intensive ventilation and the running time in the boost regime is set in the customer menu 5.5.
			Increasing the level of ventilation output	⊗	⊗	⊙	<ul style="list-style-type: none"> - Switches from control regime to the ventilation output setting regime - Press the button to increase the demand on the ventilation output setting scale 	
4.		Status indication button	Switching between automatic mode (signalling) and manual mode	⊗	⊙	⊙	<ul style="list-style-type: none"> - The factory setting is the manual regime, request for continuous ventilation - ventilation is operated at user request, ignores requests from AQS sensors - indicator light is not lit - Press to activate automatic mode, ventilation on demand - ventilation is operated according to the AQS sensor requests (if connected) - the light is on 	<ul style="list-style-type: none"> - If you activate the automatic regime, and the light at the button flashes 3 times and returns to the manual regime - no AQS sensors are attached
5.		Status indication	Filter clogged indication	⊗	⊗	⊗	<ul style="list-style-type: none"> - The clogged filter indication is triggered after approx. 6 months of unit operation (only if the unit is ventilating). - The indication is expressed by a flashing red LED. 	<ul style="list-style-type: none"> - Replace and reset the filter according to Section 6.
6.		Double-function status indication push-button	Night cooling - on (signalling)/off	⊗	⊙	⊙	<ul style="list-style-type: none"> - Unit with electronic bypass (XF1-020-ECS0xxXAx-0A0) - Press the push-button to start the night cooling function. Night cooling is used to cool the ventilated area in the summer with night cold air. The function is active for 8 hours from pressing the button. - The intensity of the supplied air can be changed even when the function is activated. When the function is completed, the values return to the settings before the function started. - Unit with mechanical bypass (XF1-020-ECS0xxXAC-1A0) - - press the button to start the automatic opening/closing function of the mechanical bypass, according to the set temperature conditions (factory settings - SET1). Once the temperature conditions are reached, the mechanical bypass opens or closes automatically. 	<ul style="list-style-type: none"> - It is recommended to activate the function after 10 p.m. During the summer months, the air is coldest around 5 a.m. The possibility of setting temperature conditions is described in Chapter 5.5.5.
			Child lock	⊙	⊙	⊙	<ul style="list-style-type: none"> - protection against manipulation by unauthorised persons. It is activated/deactivated by pressing the button for more than 6 sec. Activation/deactivation is indicated by 3 flashes of all the status LEDs 	
10.		Status indication	Ventilation operation status diode	⊗	⊙	⊙	<ul style="list-style-type: none"> - In the control regime, the diode is lit - unit is ventilating - In the setting regime, the diode flashes - you are in the required ventilation output setting regime - Ventilation can be switched off. In the setup regime, reduce output (push-button 1) until the last LED on the scale goes out. 	<ul style="list-style-type: none"> You can use the fan shutdown e.g.: in the summer - you do not wish to ventilate normally, but you wish to turn on night cooling to cool down the building that the unit serves

5.4.3. Description of the ventilation power setting range

Tab. 9

Control description on number	Symbol	Display description	Note
11.		Indication of 7 ventilation levels. The LEDs are switched on and off gradually, as required by the user	The setting values are provided in Table 19.
12.		Signalling by flashing LED for 1 min - intensive ventilation function started - can be adjusted in the customer menu	If the intensive ventilation function is activated, the entire range for setting the ventilation level is also lit

- Unit output settings

Tab. 10

Displayed LED on the controller range	Nominal flow 150 m ³ /h	Nominal flow 200 m ³ /h
	m ³ /h*	m ³ /h*
1.	49	48
2.	68	73
3.	83	95
4.	102	123
5.	120	146
6.	138	181
7.	155	207
8. - BOOST*	155	207

* Air outputs are given at the external pressure drop of 200 Pa per the nominal flow (stage 7)

** BOOST regime - maximum intense ventilation for a set period of time (ventilation intensity and ventilation time can be set in the customer menu)

5.4.4. Ventilation Output Settings

- In the regular regime, double-click on push-button 1 or 2 or 3 to enter the settings regime – LED 10 flashes (fan pictogram).
 - As long as LED 10 flashes (approx. 4 s), set the required degree of ventilation according to Table 19 or according to your request with push-buttons 1 or 3: If necessary, consult an HVAC professional for the correct ventilation performance setting.
 - If you did not manage to complete the settings (LED 10 stopped flashing), repeat the procedure.
- After setting the request, the newly set value is automatically saved (approx. within 4 s) and the controller switches to the regular regime.

5.4.5. Display of the LED Indicated Statuses on the Controller

- The LED signalling on the controller is the same for all unit types.

Blue LED range diode - ventilation level - 11; 12

- Lit - shows the selected ventilation level
- LED 1; 2; 3; 4 flashing - supply fan failure
- LED 5; 6; 7; 8 flashing - exhaust fan failure
- LED 3; 4; 5; 6 flashing - "anti-freeze" sensor failure

Status LED - fan - 10.

Blue

- lit - fan operation
- flashing - in the fan power setting mode

Blue LED status diode - summer mode - 6.

- lit - function activated
- Flashes 3 times - function inactive - poor ambient conditions

Blue LED status diode - automatic (AQS) / manual (depending on the user) - 4.

- lit - automatic mode ON (AQS)
- Flashing - reading a number
- Flashes 3 times and then goes out - no sensor (AQS)

Blue LED status diode - ON/OFF

- lit - the unit controller - ON
- flashes – cooling mode after switching off the control

Red LED status diode - filter clogging - 5.

- flashing - indicates filter clogging

Common functions for all the blue status diodes - 3 flashes for activation and deactivation of the "child lock" function

- 1 flash for indicating that the "child lock" function is active
- 3 flashes when starting the BOOST function - cannot be activated - low outdoor temperature

Fig. 51

5.4.6. Hidden Regulation Functions

- The control behaviour includes automatic processes that ensure optimal operation of the unit with emphasis on the maximum service life and efficiency of the operation. These processes are part of the manufacturer's factory setup and know-how. The user cannot change them. As a result of these automatic processes, the behaviour of the unit may be different from that assumed by the user.
- These are mainly automatic processes:
 - unit preheating control – switches only when necessary,
 - anti-freeze logics triggering – measures against recuperator freezing,
 - minimum preheating, heating operation time – protective function,
 - cooling after switching off pre-heating, heating – protective function against overheating of the exchanger,
 - Unit control using the AQS sensors - automatic functionality according to ventilation needs,

5.4.7. Automatic Unit Control using AQS Sensors



- AQS sensors for sensing the CO₂ concentration in the room and RH humidity sensors can be connected to the unit using accessories, see Chapter 4.2.2.
- After connecting the AQS sensors to the unit, activate the automatic regime function - button 4.
- The unit responds by continually controlling the need for real-time ventilation triggered by sensors:
 - When the concentration of the monitored substances is reached, ventilation shall be switched on with the minimum flow rate:
 - CO₂ – 800 ppm,
 - RH – 65%.
 - If the reduction of the concentration of the monitored substances in the room is not achieved, the unit controller increases the flow up to the maximum flow value set by the user.
 - The unit controller will start to decrease the flow rate continuously again while reducing the concentration.
 - The aim of the regulation – ventilation, is to find the ideal degree of ventilation (flow rate) depending on the concentration of the monitored substance in the ventilation room. For this reason, the unit may ventilate for a long time until it reaches safe limits of concentration or complete ventilation of the substance being monitored.
 - When the concentration is reduced to a specified value, ventilation is switched off and the unit is switched to the standby regime:
 - CO₂ – 700 ppm,
 - RH – 60%.
 - If there is a requirement for ventilation from several sensors, the controller gives priority to a sensor with a higher ventilation requirement.

5.5. Customer Menu

5.5.1. Service Menu Access



- The unit is connected to its power supply - the main switch is on (position I)
- The controller has been loaded - see Chapter 5.2. – item 1)
- The controller is switched off - if necessary, switch it off (the ON/OFF push-button must not be lit or flashing - 2.) - the unit is switched off by the controller



- Press key 1. “reducing fan output level” for 6 s.
- After 6 s, the entire fan setting scale flashes once - you are in the customer menu.



- The automatic display time of the customer menu is 15 s from the last activity. After this time, the adjusted values are saved, and the controller is switched off. Repeat the previous steps to re-enter the customer menu.

Fig. 52

5.5.2. Setting the air output for the BOOST regime - 1st screen

- After entering the customer menu, the air output setting scale 11.; 12. immediately displays the set air output for the BOOST regime
 - o The BOOST regime factory setting is at maximum air output - all the LEDs are lit to indicate fan output
- The air output is adjusted using push-button 1 (decrease) and push-button 3 (increase). The display on the scale is always two LEDs at a time



Fig. 53

- BOOST regime air output setting level

Tab. 11

Nominal power of the unit m ³ /h	Displayed LED on the controller range			
	1+2 m ³ /h*	3+4 m ³ /h*	5+6 m ³ /h*	7+8 m ³ /h*
150	102	120	138	155
200	123	146	181	207

* Air outputs are given at an external pressure drop of 200 Pa per the nominal flow rate
Highlighted values - factory settings

- To save the set values, leave the controller idle (approx. 15 s) until it switches off.

5.5.3. BOOST regime run time setting - 2nd screen

- After entering the customer menu, press push-button 4, where the LED lights up
- The LED at push-button 4 will flash - you are in the BOOST regime
- On the air output setting scale 11.; 12. you will see the set BOOST running time
 - o The factory setting is 1min - 1 and 2 LEDs are lit
- Set the running time using push-button 1 (decrease) and push-button 3 (increase).

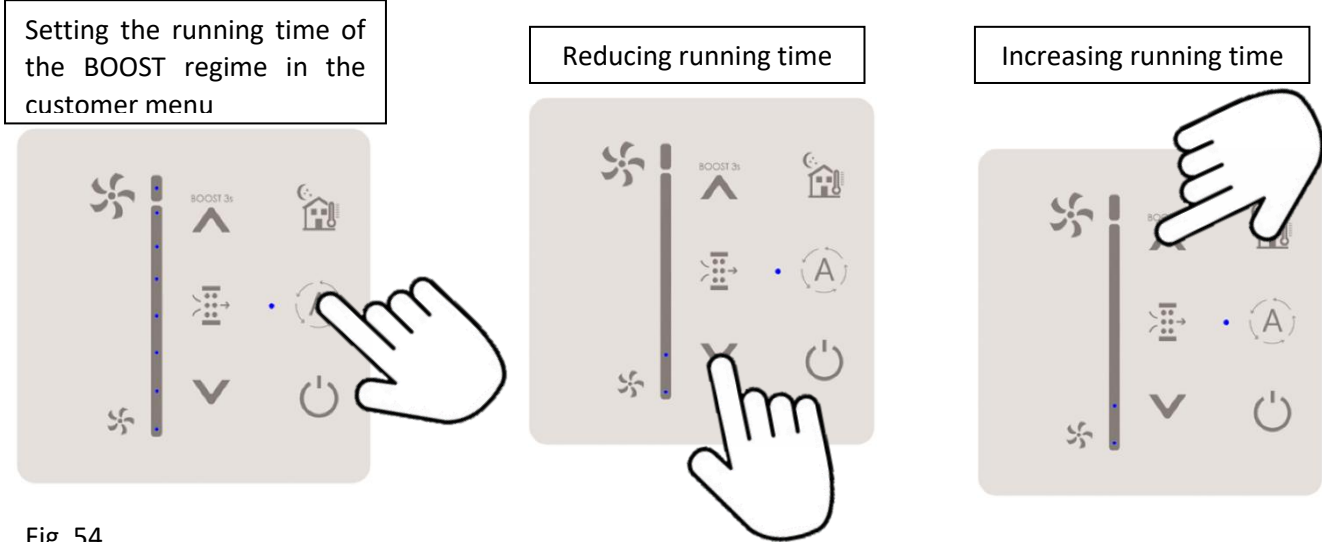

Fig. 54

- Options for setting the running time in the BOOST regime

Tab. 12

Displayed LED on the controller range	1.	2.	3.	4.
Running time in the BOOST regime	0,5 min	1 min	2 min	4 min
Displayed LED on the controller range	5.	6.	7.	8.
Running time in the BOOST regime	7 min	10 min	15 min	20 min

Highlighted value - factory setting



- **If the unit is connected to a parent BMS and the BOOST running time is set to a different time than can be set on the unit controller, the nearest LED to which the set time in the BMS is rounded flashes.**
- To save the set values, leave the controller idle (approx. 15 s) until it switches off.

5.5.4. Fan distribution setting - 3rd screen

- The fan distribution setting is used to increase the air output of the supply air. This means that the building served by the unit is pressurized (more air is supplied than exhausted).



- **Consult a specialist in the field of ventilation (designer) for the correct setting of the fan distribution (overpressure), and consult a chimney sweep if used in rooms with a fireplace.**
- **Incorrect fan distribution settings can result in reduced comfort in the building, improper operation of the unit and thus reduced unit life.**



- Press button 6 after you enter the customer menu.
- The LED on push-button 6 lights up - you are in the fan distribution setting mode
- On the air power setting scale 11.; 12, there you will see the fan distribution settings
 - o Factory setting is equal pressure - 0 fan distribution - 1 LED diode is lit

- Set the fan distribution with button 1 (decrease) and push-button 3 (increase).

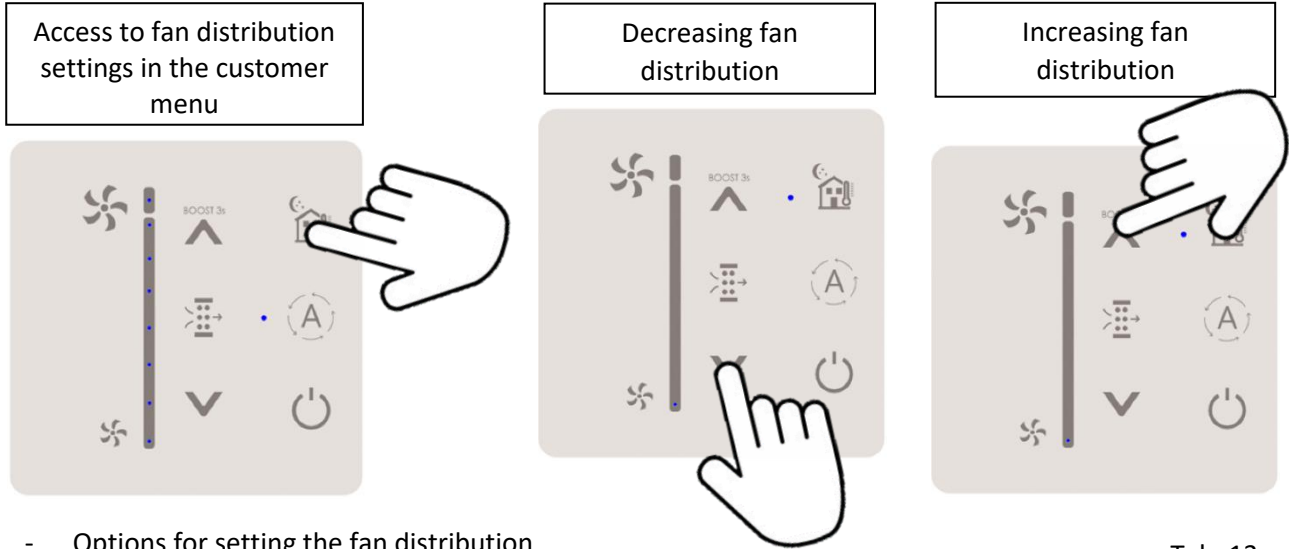

Fig. 55

- Options for setting the fan distribution

Tab. 13

Displayed LED on the controller range	1.	2.	3.	4.
% fan distribution	0% - equal pressure	5 %	10 %	15 %
Displayed LED on the controller range	5.	6.	7.	8.
% fan distribution	20 %	25 %	30 %	35 %

Highlighted value - factory setting



- To return to the BOOST regime settings, press push-button 4.
- To save the set values, leave the controller idle (approx. 15 s) until it switches off.

5.5.5. Setting temperature conditions for mechanical automatic bypass (SET1/SET2) - 4th screen



- Used to set the opening/closing temperature conditions of the mechanical bypass on the Comfort+ (XF1-020-ECS0xxXAS-1A0) unit with regulation
- Temperatures in each temperature condition mean: supply air temperature from the exterior (outdoor environment) / supply air temperature from the interior (indoor environment)
- Press push-button 6 twice after you enter the customer menu.
- LED at push-button 6 flashes - you are in the mode of setting the temperature conditions for opening/closing the mechanical bypass
- On the air output setting scale 11.; 12. you will see the set temperature condition
 - o Factory setting is SET1 (19°C/22°C) - 1 LED is lit
- Set the temperature condition using push-buttons 1 (decrease) and push-button 3 (increase).

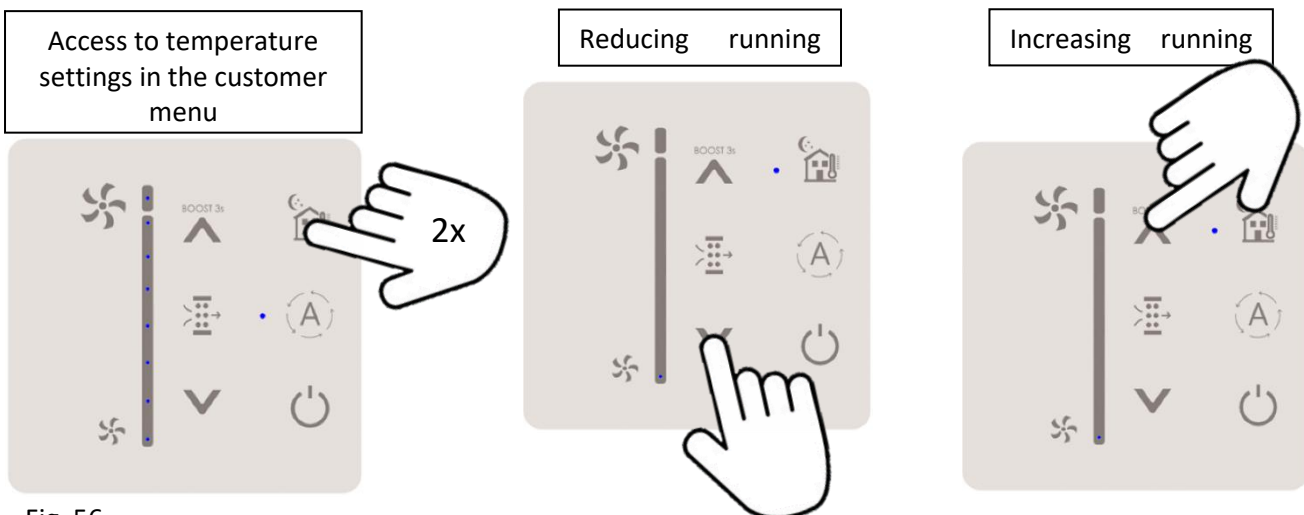

Fig. 56
Version 002 – GBR (25.05.2025)

- Temperature Setting Options

Setting minimum temperature conditions for bypass start-up	Displayed LED on the controller range	
	1	2
Fashion	SET 1	SET 2
Temperature conditions - exterior / interior	19°C / 22°C	19°C / 25°C

hysteresis 2°C

Highlighted values - factory settings



- To return to the BOOST regime settings, press push-button 4.
- To save the set values, leave the controller idle (approx. 15 s) until it switches off.

6. Replacing Filters

- Before starting any service work, the power supply must be switched off. **During the assembly, the switch must be secured against being switched on again by an unauthorised person.**
- The unit is equipped with a filter clogging countdown for approx. 6 months (approx. 4400 hours). The countdown reads the unit's real operation.
- Filter clogging depends on the environment, in which the unit operates. Especially, on the dustiness of the surrounding air – the more dust particles are contained in the air, the sooner the filter box is clogged. Therefore when filter clogging is indicated, always consider replacing them.
- The filter replacement control is indicated on the control panel by a red flashing LED titled “filter” (position 5 on the controller).
- Before starting to replace filters, make sure you have new ones:
 - o Filter M5 XF-020-FILTER-M5
 - o Filter F7 XF-020-FILTER-F7

6.1. Filter Removal

- Using the textile straps, remove the plastic caps from the unit lid marked FILTER.
- Pull the filters, check them and or replace with a new filter

1	REMOVE THE FILTER CAPS USING THE TEXTILE STRAPS	2	PULL THE FILTERS OUT USING THE HOLDERS
----------	---	----------	--

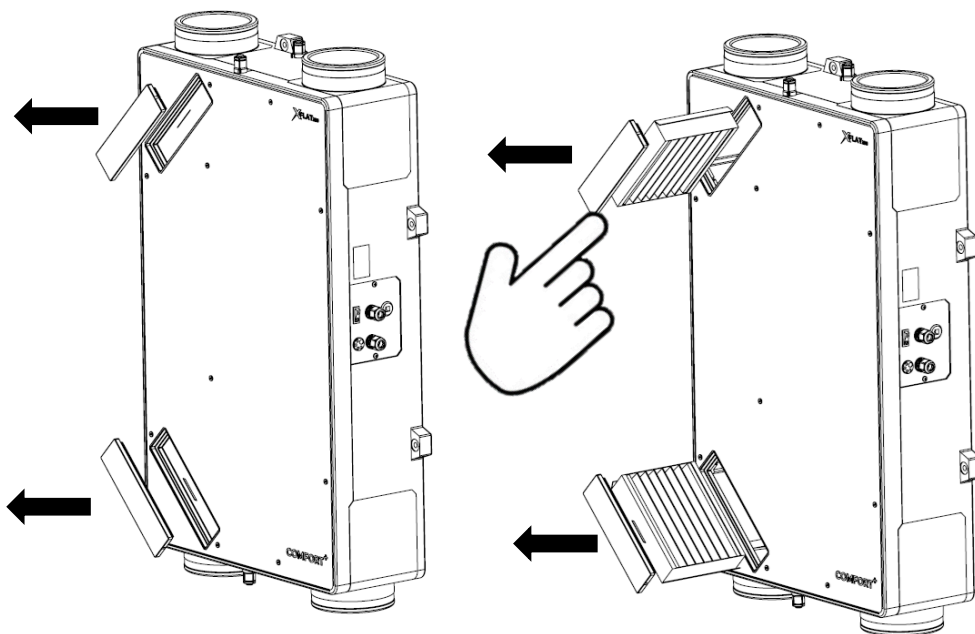

Fig. 57

6.2. Filter Inserting



- Pay attention to the correct orientation of the filter before it is inserted into the unit with regard to the air flow
- Insert new filters into the unit.
- Align the filter holders so that they do not interfere with the assembly of the plastic filter caps.
- Fit the filter caps into the unit lid so that they are flush with the unit lid.

1 INSERT NEW FILTERS

2 ATTACH THE FILTER CAPS

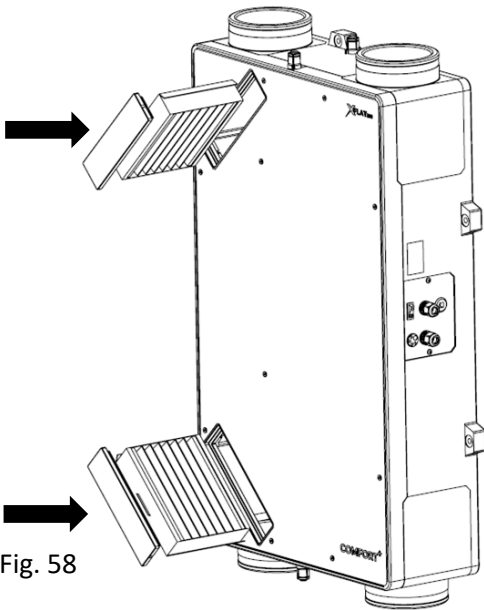
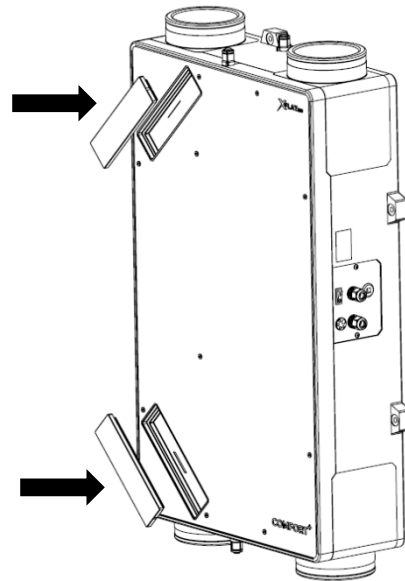

Fig. 58



6.3. Reset filter countdown

- Resetting the filter is always done after the red indicator light 5 is on. FILTER.
- Reset the filter in the normal operating state of the unit (sleeping or control regime):
 - o Press button 4 and button 6 at the same time.
 - o After approx. 4 s, red light 5 FILTER will go out. This will reset the timer and restart the fan running time.

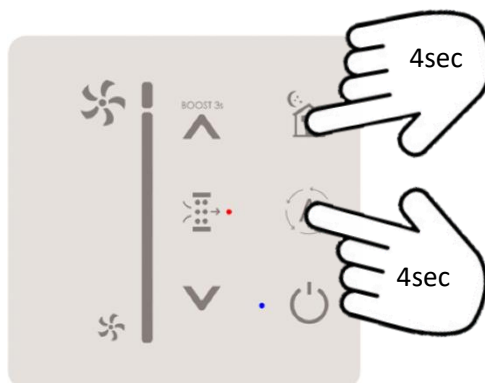

Fig. 59



- If the filters are not properly replaced (cleaned), the functionality of the unit may be reduced.
- Never operate the unit without air filters, the recuperator may be damaged.

7. Regular Maintenance and Cleaning of Xflat Units



- Before opening the unit during its maintenance and cleaning, the unit must be disconnected from the power supply



- Maintenance and cleaning must be performed at regular intervals; otherwise, the functionality of the unit may be impaired.

- Children may not perform cleaning maintenance without supervision.

- Compressed air, steam, solvents, aggressive chemicals, abrasive cleaning agents, or sharp items must not be used to clean the unit.

- Perform maintenance and cleaning of the unit in regular cycles to ensure its hygienic operation. In the case of regular filter replacement (use the manufacturer's original filters) as indicated, the maintenance interval of the maximum of 2 years or at intervals determined by the relevant national regulations or practices must be observed.

- If the unit is not used for a longer period of time, it is necessary to switch off the power supply to the unit.

- Service work that is beyond the scope of routine maintenance may only be performed by an authorised service centre or the manufacturer.



- Regular maintenance must include:

- o Visual inspection of the unit casing - Chapter 7.1.1.,
- o Visual inspection of the supply cable – Chapter 7.1.2.,
- o Cleaning of fan chambers and fans — Chapter 7.2.1.
- o Visual inspection and cleaning of the heat recovery exchanger - Chapter 7.2.2.,
- o Visual inspection - cleaning of external preheating, reheating if installed - Chapter 7.2.4.,

- For cleaning the unit from coarse dirt or dust, use a vacuum cleaner or damp cloth with a common cleaning agent (e.g. soapy water).

7.1. Inspection - Cleaning the Unit's Exterior

7.1.1. Visual Inspection of the Unit Enclosure

- The unit can be cleaned on its entire surface.
- Visually inspect the outer casing of the unit for excessive soiling, damage:
 - o If the smooth surfaces of the casing are dirty, wipe them with a damp cloth with a common cleaning agent (e.g.: soapy water),

7.1.2. Visual Inspection of the Supply Cable

- Visually check that the supply cable is not damaged, loosen, or torn from the connecting peripherals.



- In case of damage, consult with the person competent for this activity with the valid authorisation and knowledge of the relevant standards and directives.

7.2. Inspection - Cleaning of the unit interior



- Pay particular attention to the disassembly of the internal components of the unit. Improper disassembly may cause the unit to malfunction or limit its functions.
- Unscrew the 10x M6x20 screw securing the unit cover
- Remove the filter caps using the textile straps
- Remove the filters
- Remove the unit lid using the filter cap holes (position 9)

1 REMOVE THE SCREWS

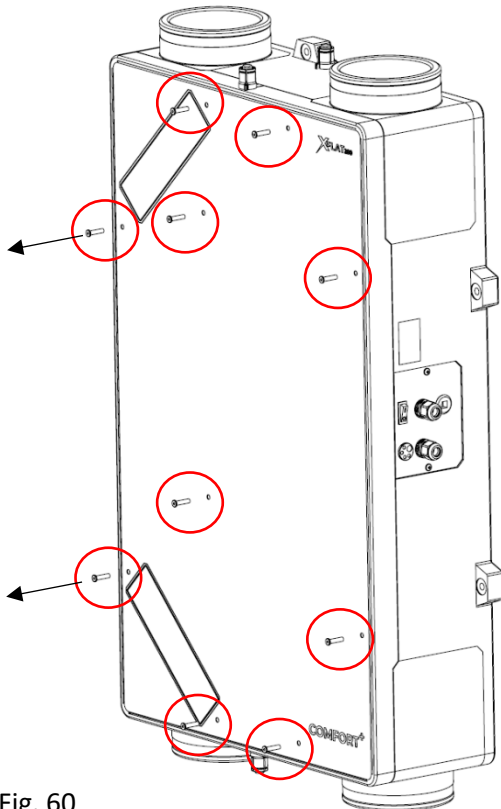

Fig. 60

2 LIFT OFF THE UNIT COVER TO ACCESS ITS INTERNAL COMPONENTS

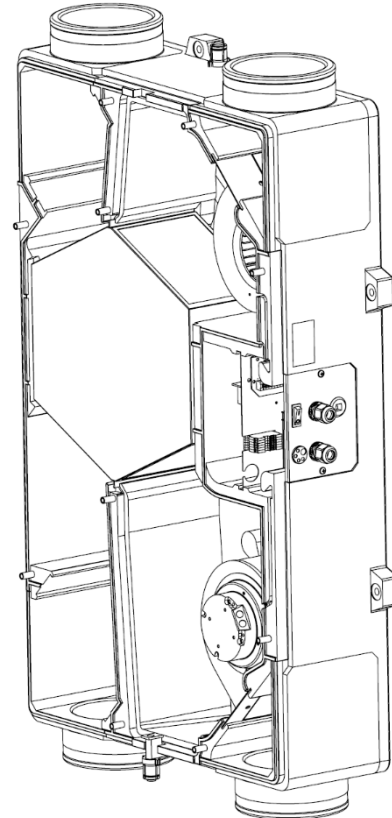

Fig. 61

- Take extra care when removing the unit lid - the connections between the lid and the unit body are sealed in the recuperator location. The sealed joint may resist during disassembly.



- The following sub-categories of the instructions are consecutive actions to be followed in the order shown.

7.2.1. Cleaning the Fan Chamber and Fans

- For better handling during cleaning, always clean only one fan chamber and fan.
- Release the cables in the fan groove. Take extra care not to damage the fitting when removing them. Cables are secured with adhesive against spontaneous dropping.
- Carefully slide the fan beam assembly (position 11) out of the groove in the unit body.
- You can flip the fan holder with the fan for better access by 180°.

1) Fan placement in the unit

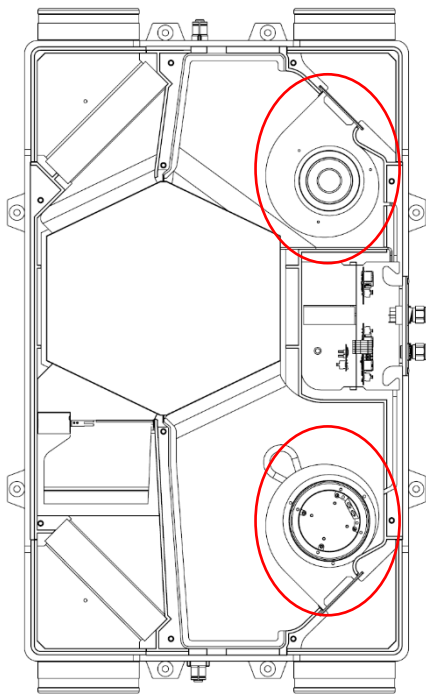

Fig. 62

2) Release the fan cables from the grooves

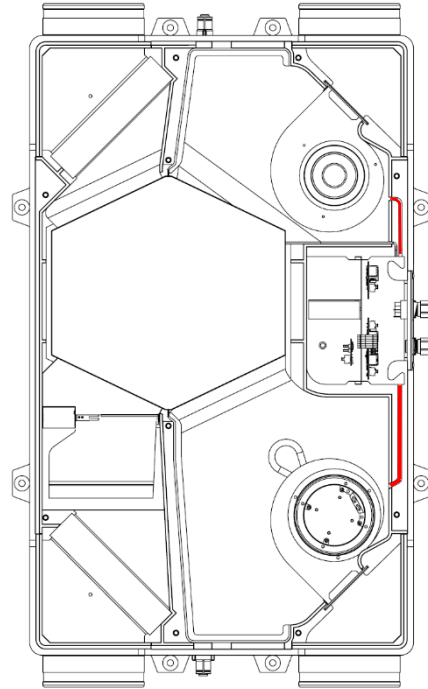

Fig. 63

3) Extending the fan sub-assemblies

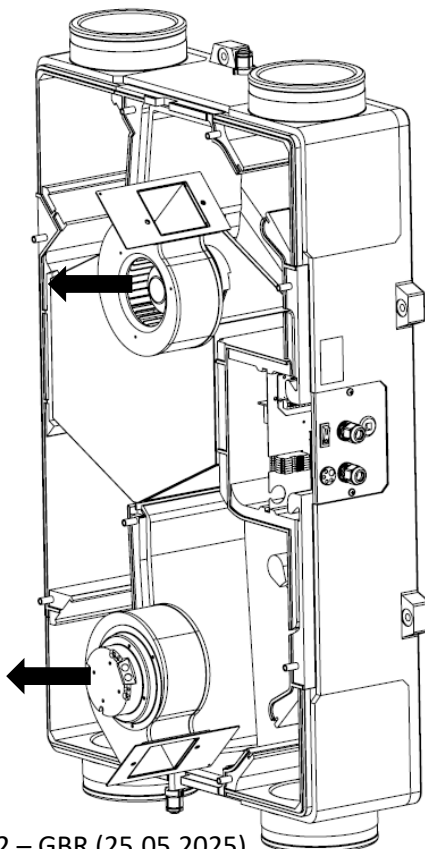
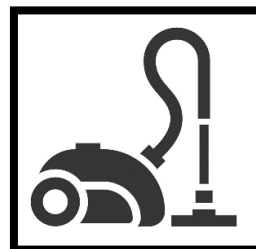

Fig. 64

- Vacuum dirt from the fan chamber and, if necessary, wipe it with a damp cloth with a common cleaning agent (e.g. soapy water).
- With extra care, vacuum dust from the fan assembly and, if necessary, wipe it with a damp cloth with a common cleaning agent (e.g. soapy water).
- After cleaning the fans and fan chamber, reassemble in the reverse manner. Ensure that the cables are properly seated in the groove so that they cannot be crushed by the lid.



7.2.2. Visual Inspection and Cleaning of the Heat Recovery Exchanger

- Then, visually inspect and clean the heat recovery exchanger (position 12)
- Vacuum the exchanger with a vacuum cleaner or use the brush attachment on the vacuum cleaner. Always vacuum the exchanger at the end to remove fine dust.

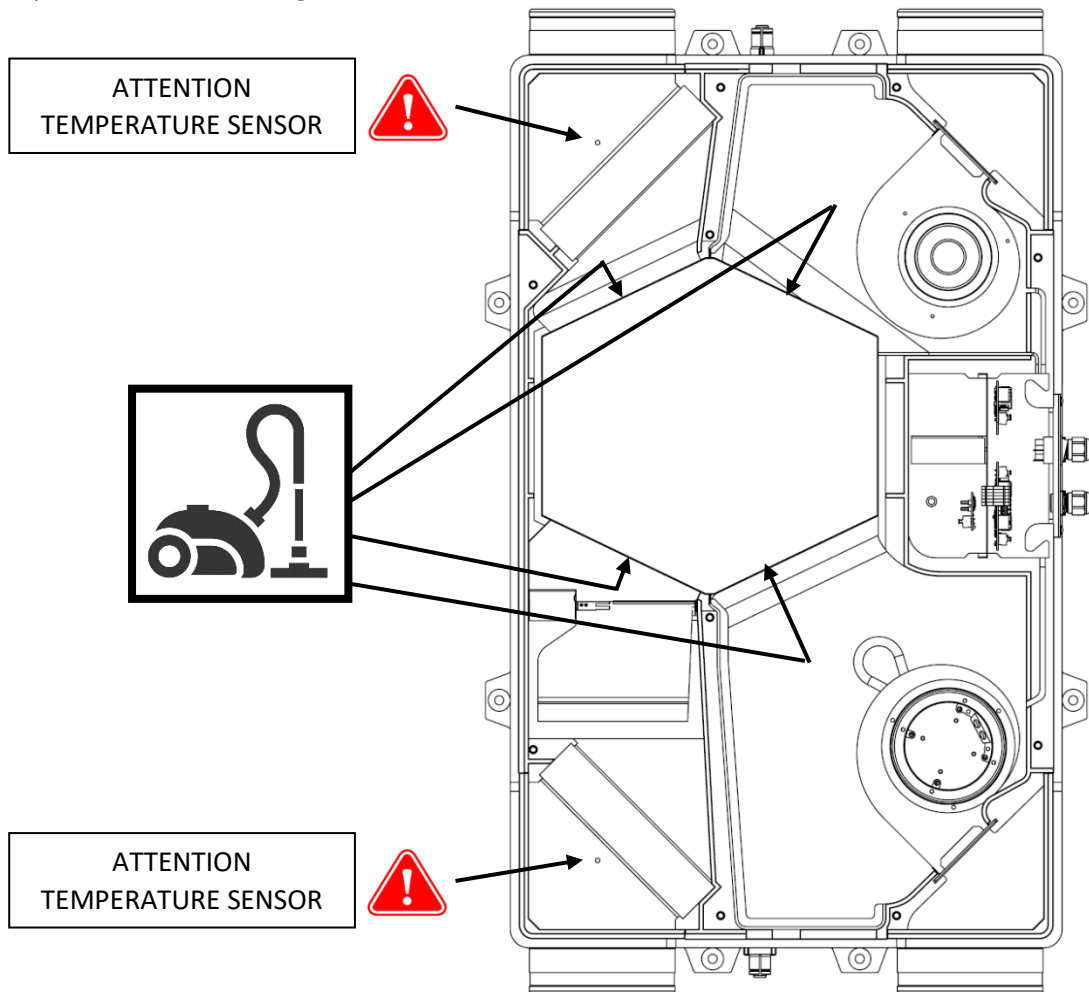

Fig. 65

SLIDE THE RECUPERATOR OUT USING THE CENTRE STRAP

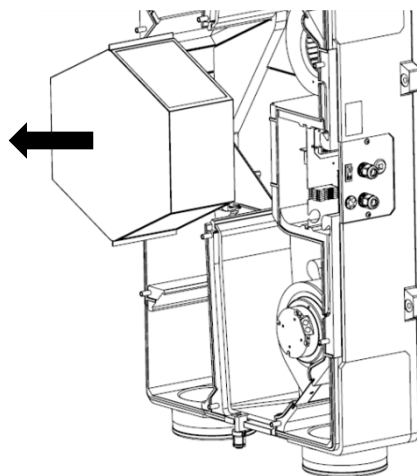

Fig. 66

- Treat the removed heat exchanger with a disinfectant or antibacterial product suitable for cleaning and disinfecting aluminium and plastic. Allow the heat exchanger to dry thoroughly before inserting it into the unit!
- **Do not use any sharp tools or hard-bristled brushes to clean the heat exchanger. Avoid pressure washing and chemicals. There is a risk of permanent damage to the heat exchanger!**
- After cleaning, slide the heat exchanger back into the unit body.



7.2.3. Reassembly - sealing of the Xflat 200 unit

- After checking and cleaning, reassemble the internal components into the unit according to the individual previous chapters by reversing the procedure.
 - o Fit and then push the lid onto the unit body. Make sure the unit lid is seated correctly.
 - o Screw in 10x M6x20 screw to secure, seal the unit lid.

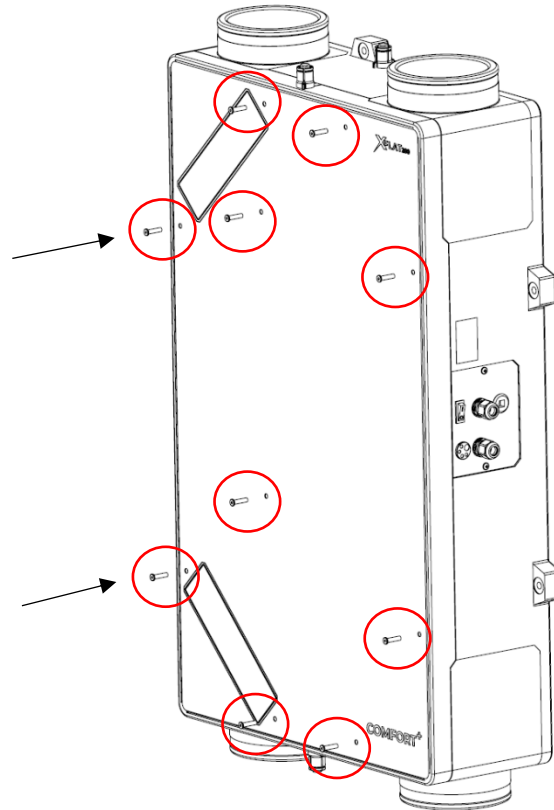

Fig. 67

7.2.4. Visual inspection - cleaning of the external preheater, reheater - if installed

- The external preheater and reheater are located in the air ducts that are connected to the unit
 - o Preheater - ODA air duct designation
 - o Reheating - air duct marked SUP



- **Perform maintenance as recommended by the heater manufacturer.**

- The general rules for cleaning pipe heaters (preheater, reheater) are:

- o Clean the heater by vacuuming it.
- o **Never clean the piping heater with a damp cloth.**
- o **Check the supply cable and its connection to the heater supply terminal block.**



- **The manufacturer of the unit is not responsible for poorly performed or neglected maintenance of the external piping heater.**

8. Servicing



- **Warranty and non-warranty servicing may only be performed by a qualified professionally trained worker and only using original spare parts.**

- **The manufacturer reserves the right to make changes to the device that do not affect the fundamental characteristics of the device.**

8.1. Error Messages – Troubleshooting Procedure

Tab. 15

Error No.	Error message, malfunction	Possible cause of the malfunction	Troubleshooting
1.	The unit does not start	The power cable is not connected	- check the mains connection - check the activation of the safety element
		The main switch is in position 0	- set the switch to position I
		The entire controller loading process did not take place	- Switch the unit off with the main switch and switch it on again, wait until the controller has finished loading - the controller stops flashing
		Hold down push-button 2 (ON/OFF) for a short time, approx. 3 sec	- hold down button 2 (ON/OFF) until the LED above the button lights up
2.	The unit does not start when first put into operation - LED above button 2 is lit	The demand for ventilation and heating is switched off	- Enter the unit setup regime and check the ventilation output request settings - Make the settings per Chapter 5.4.2. table 14
3.	Red indicator light above the FILTER sign is flashing	Filter clogging indication	- replace the filter according to Section 6.
4.	No or low ventilation output even when the unit is set to the maximum power	Clogged filter	- replace the filter according to Section 6.
		Contaminated - blocked piping, unit outlets	- Inspect the piping. Clean the unit per Chapter 7.
5.	Unit started to be too noisy	Clogged filter	- replace the filter according to Section 6.
		Fan distribution wrongly set	- Check and re-set the fan distribution per Chapter 5.5.4.
		Defective motor bearing	- contact the unit supplier
6.	External electric heating of the unit does not heat (preheating, reheating)	Clogged filter - no flow	- replace the filter according to Section 6.
		Contaminated - blocked piping, unit outlets	- Check and clean the unit according to Section 7.
		activated heat exchanger protection against overheating	- Shut off unit and heater with the main switch. Check the thermal protection - thermostat with manual reset. If the problem persists, contact the unit supplier
7.	Unable to activate the night cooling function - bypass (button 6) - The button signalling flashes 3 times and the function does not switch on	Function start requirements are not met - outside temperature too low	- Wait for the outside temperature to rise. The function is active only at summer temperatures.
8.	The night cooling function cannot be switched on (button 6.) - all the status diodes flash once (at push-buttons 6, 4, 7, 10), the function does not switch on	BOOST function active	- Wait for the BOOST regime to end - Switch off the BOOST function per Chapter 4.2.5.
		Active child lock function	- Disable the child lock function according to Chapter 5.4.2.
9.	The BOOST mode cannot be switched on - status diodes flash once or 3 times (at buttons 6, 4, 7, 10), the function does not switch on	3 flashes - very low outdoor temperature	- Wait for the outdoor temperature to rise
		1 flash - child lock function is active	- Disable the child lock function according to Chapter 5.4.2.
10.	The automatic mode cannot be started - when the button 4 is pressed, the indicator flashes 3 times or lights	3 flashes - unit is not fitted with any AQS sensor	- You have no AQS sensor connected. - Check the AQS sensor wiring
11.	When any button is pressed, the status diodes flash once (at buttons 6, 4, 7, 10)	Active child lock function	- Disable the child lock function according to Chapter 5.4.2.
12.	The unit is inoperable and the 4 LEDs on the range for adjusting the ventilation power on the control panel are continuously flashing	- diodes 1; 2; 3; 4 are flashing	Supply fan failure
13.		- diodes 5; 6; 7; 8 are flashing	Exhaust fan failure
14.		- diodes 3; 4; 5; 5 are flashing	Faulty anti-freeze sensor
			- Switch off the unit at the control panel and main switch, leave the unit off for approx. 10 sec - restart the unit - If the error persists after restarting the unit, contact the unit supplier

8.2. Malfunction Persists

- Restart the unit – switch off the unit on the controller (push-button 2), switch off the unit using the main switch (position 15). Wait approx. 30 s and restart the unit.
- In the event of a persistent failure of the unit, do not attempt to repair the unit yourself.
- Switch the unit off using the main switch and disconnect it from the mains.
- Secure the unit against restarting or handling by an unauthorised person.
- Contact your seller.

9. Final Decommissioning, Dismantling, and Disposal

- At the end of the machine's service life or when it would be uneconomical to repair it, dismantle the machine completely.
- During the dismantling process, the generally applicable safety regulations must be observed for the safe execution of all the work activities.
- - After complete disassembly of the machine, the individual parts are disposed of in accordance with Directive 2012/19/EU and the applicable regulations of the country.
- Separate the metal components by the type of metal and hand them over to the relevant organisations dealing with the reusable waste collection.
- The parts made of plastic materials and rubber that are not subject to natural decomposition shall be sorted out and sold to an organisation dealing with collection of such reusable waste materials.
- Parts of electrical equipment are handed over to the organisation responsible for electrical waste collection.



All unwanted or end-of-life products and their packaging should be taken to appropriate collection and recycling facilities. A properly recycled product can be reused and contributes to the protection of the environment and health. Disposal must be in accordance with Directive 2012/19/EU and the applicable national regulations. Do not dispose of the product in municipal waste - use the designated collection system.



10. Warranty

The warranty per unit is valid according to legal regulations. The warranty only applies if all the assembly and maintenance instructions have been followed. The warranty covers manufacturing defects, material defects, or device operation defects. We do not guarantee the suitability of using the unit for special purposes, determination of suitability is fully within the customer's competence.

The warranty does not cover defects caused by:

- Improper handling,
- During transport (damage caused by transport – financial compensation must be resolved with the carrier),
- Failing to comply with the service conditions,
- Incorrect electrical connection or protection,
- Incorrect operation,
- Product intervention,
- Regular wear and tear,
- Due to a natural disaster.

If the warranty is claimed, it is necessary to submit a report (provided in the product documentation) containing:

- Complainant/company information,
- Date and number of the sales document,
- Detailed description of the defect,
- Data on socket protection,

- Photo of the product's manufacturing label and, where appropriate, a serial number,
- Photo from the product's assembly site,
- Measured product values: air temperature, voltage, current.

In the case of both warranty and post-warranty service, contact your supplier or assembly company that performed your assembly. The method of handling a warranty repair is carried out at the unit assembly site or as agreed. The method of resolving warranty repairs is exclusively at the discretion of the company's service centre. The complaining party shall receive a written statement on the result of the complaint – warranty repair. In the case of an unjustified complaint, all the costs relating to such complaint shall be borne by the complainant.

11. In Conclusion

If you have any questions about this product, do not hesitate to contact us.

Contact Address:

Xvent s.r.o.
Poděbradská 289
53009 Pardubice-Trnová
Czech Republic
www.xvent.cz

