

Zehnder EVO 4

Wall or ceiling mounted mechanical supply and extract ventilation
with heat recovery (MVHR)

Product data sheet

always the best climate



EVO 4

The Zehnder EVO 4 has been developed as an ideal solution for apartments and small homes where efficient use of space is important. Installation within a suspended ceiling is possible, even in small spaces, thanks to its compact design with minimal dimensions and rotatable spigots. It can be left or right handed in addition to being ceiling or wall mounted. It contains features such as its automatic true summer by-pass, high heat recovery efficiency and upgradable high grade filters providing a comfortable, healthy and energy-efficient indoor climate.



Example controls - sold separately



EVO Switch



EVO Sense

Key Benefits

- Ultra compact dimensions (L 1160mm x W 600mm x H 269 mm)
- 100% full and filtered summer bypass.
- Flexible installation options either ceiling or wall mountable.
- Tool free filter access.
- Constant-flow ventilation, quiet operation and low energy use.
- Monitoring and control via wired remote controls or wireless connectivity
- Just 269 mm thick, Zehnder EVO 4 is ideal for installation in false ceilings and what's more the inclination to enable condensate drainage is built-in to the unit as standard.
- Adjustable spigots for flexibility on duct connections.
- Tool free filter access.
- Volt free contact boost capability.
- RFZ wireless connectivity option.
- Internal pre-heater option.
- ISO Coarse / ISO ePM1 (G4 / F7) filter combination as standard for pre-heater version.
- ISO Coarse (G4) and ISO ePM1 (F7) filter options.
- Enthalpy cube option.
- Passive House certified.

Article Numbers

Description	Product Code
Unit	
Zehnder EVO 4	471 100 163
Zehnder EVO 4 with pre-heater, factory handed	471 100 155
Zehnder EVO 4 with pre-heater, mirror handed	471 100 156
Zehnder EVO 4 with enthalpy exchanger	471 100 164
Controls	
Controls, Zehnder EVO Switch wireless controller for use with Zehnder EVO 2/3/4	471 100 017
Controls, Zehnder EVO Sense controller for use with Zehnder EVO 2/3/4	471 100 018
Controls, Zehnder EVO CO2 sensor for use with Zehnder EVO 2/3/4	471 100 022
Controls, Zehnder EVO Humidity sensor for use with Zehnder EVO 2/3/4	471 100 023
Controls, Zehnder EVO Connect ModBus for use with Zehnder EVO 2/3/4	471 100 020
Controls, Zehnder EVO Connect ModBus to KNX converter for use with Zehnder EVO 2/3/4	471 100 024
Filters	
Filter for Zehnder EVO 3/4, ISO Coarse / ISO ePM1 (G4 / F7), 2 Pieces	471 100 067
Filter for Zehnder EVO 3/4, ISO Coarse (G4), 2 Pieces	471 100 066
Filter for Zehnder EVO 3/4, ISO Coarse (G4), 10 Pieces	471 100 188
Filter for Zehnder EVO 3/4, ISO ePM1 (F7), 10 Pieces	471 100 190

Article Numbers

Description	Product Code
Accessories	
Heat exchanger for Zehnder EVO 3/4	471 100 052
Enthalpy exchanger for Zehnder EVO 3/4	471 100 053
Condensate waterless drain trap kit for Zehnder EVO 1/2/3/4	471 100 021

SAP PCDB

	SFP (W/l/s)		Efficiency (%)	
	2009	2012	2009	2012
K+1	-	-	-	-
K+2	-	0.71	-	89%
K+3	0.65	0.74	89%	87%
K+4	0.72	0.91	88%	86%
K+5	0.78	1.07	87%	85%
K+6	0.91	1.30	86%	85%
K+7	1.03	1.56	85%	84%

SEC Class



Based on average climate with local demand control

Passive House Certification

	Standard heat exchanger
Air flow range	139–322 m ³ /h
Heat recovery rate	HR = 80%
Specific electric power	Pel,spec = 0.37 Wh/m ³



Pressure Curve

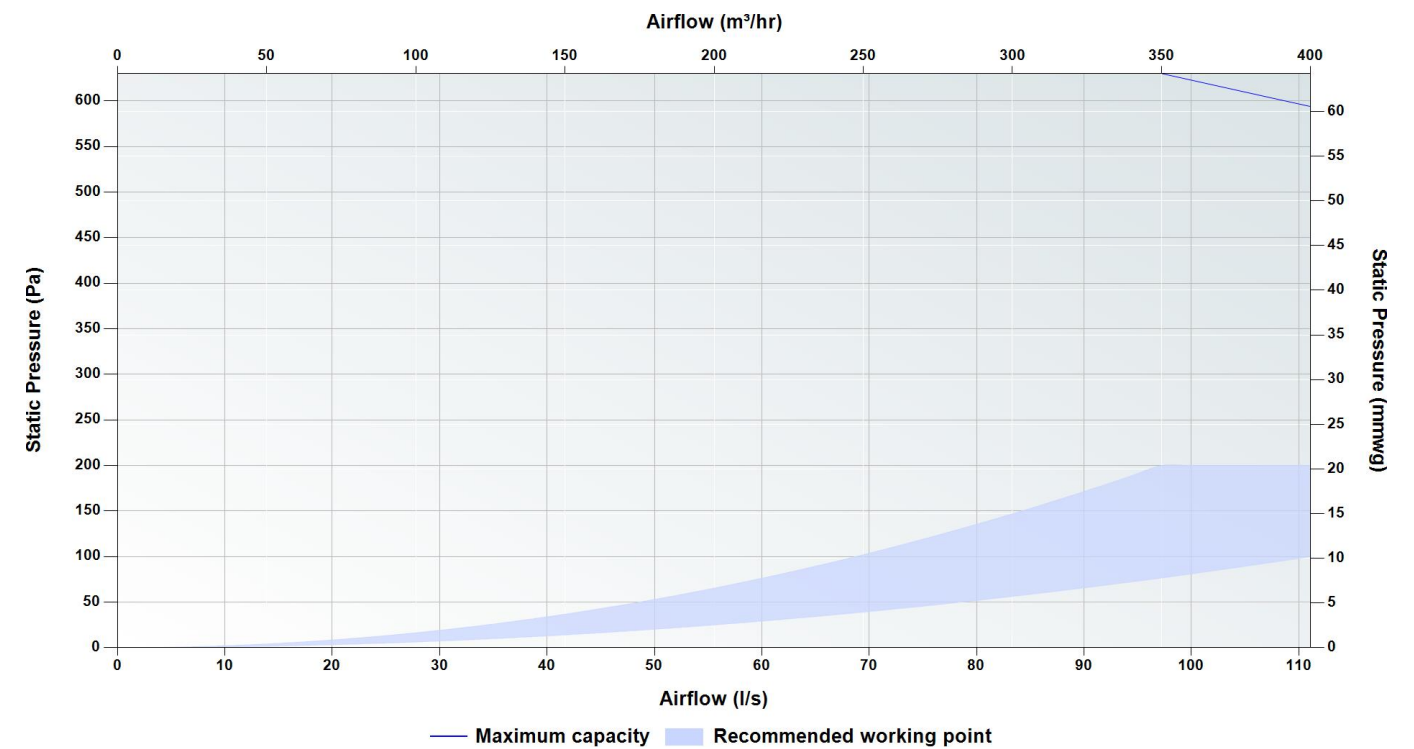

Sound Data

Speed	Test area	Octave Band (Hz) Sound Power Level, dB							dB(A) @ 3 m
		125	250	500	1000	2000	4000	8000	
40%	Casing	38.5	36.6	34.2	35.6	27.6	19.1	14.3	20.6
	Supply	59.6	55.2	52.4	45.2	34.8	28.4	21.6	
	Extract	49.4	42.5	37.4	30.8	17.1	7.2	7.9	
60%	Casing	48.0	47.6	43.1	47.9	40.5	34.2	29.1	32.4
	Supply	67.2	64.5	61.7	56.1	47.7	43.8	40.2	
	Extract	59.4	54.1	47.7	42.2	30.6	19.9	14.3	
80%	Casing	54.8	55.4	50.3	55.5	49.6	44.1	39.9	40.4
	Supply	72.1	70.8	68.3	62.4	57.0	53.3	51.6	
	Extract	66.1	62.0	55.1	48.9	40.1	30.4	22.9	
100%	Casing	58.9	59.8	55.7	58.4	55.2	48.8	46.6	44.5
	Supply	74.2	74.1	72.2	64.1	62.8	56.9	56.0	
	Extract	69.6	65.9	59.6	50.9	45.3	38.5	33.6	

Tested according to [BS EN 13141-7:2010](#). Supply and Extract showing induct sound power levels calculated in accordance with ISO 5135:1999. Casing dB(A) @ 3 m given as hemispherical.

Air Direction/Connection

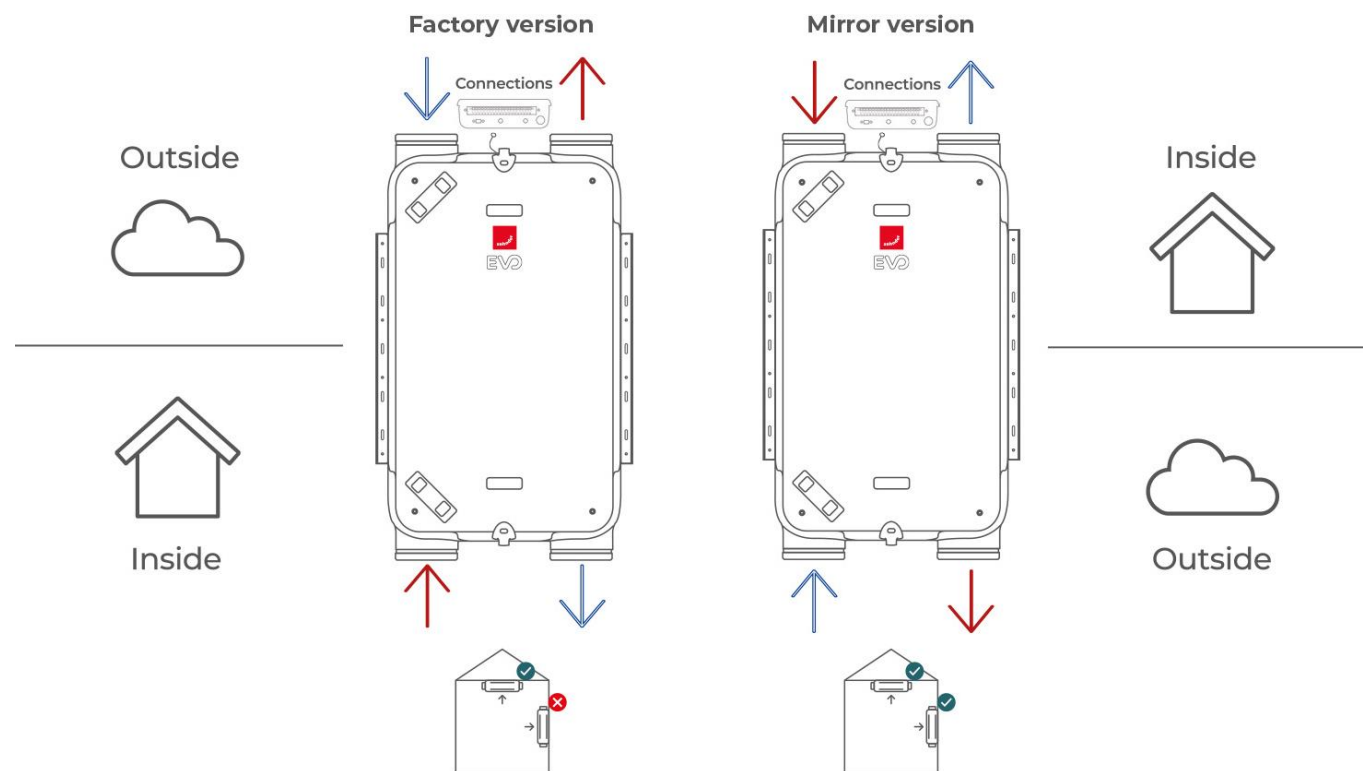

Technical Specification

Weight	39 Kg
Ducting \varnothing	Internal - 160 mm
Condensate connection \varnothing	1/2 inch
Filter grade	Standard - ISO Coarse / ISO Coarse (G4 / G4) Optional - ISO Coarse / ISO ePM1 (G4 / F7)
Materials	Internal EPP / ABS External coated sheet steel
Supply voltage	230 V / single-phase / 50Hz
Maximum power consumption including / excluding pre-heater	1370 W / 370 W
Current draw including / excluding pre-heater	7.62 A / 3.42 A
Fuse rating including / excluding pre-heater	10 / 6 amp
Specific Fan Power	0.71 W/l/s
Heat Recovery Efficiency	89%
IP Rating	IP40

Dimensions

Height	269 mm
Width	600 - 700 mm
Depth	1160 - 1260 mm

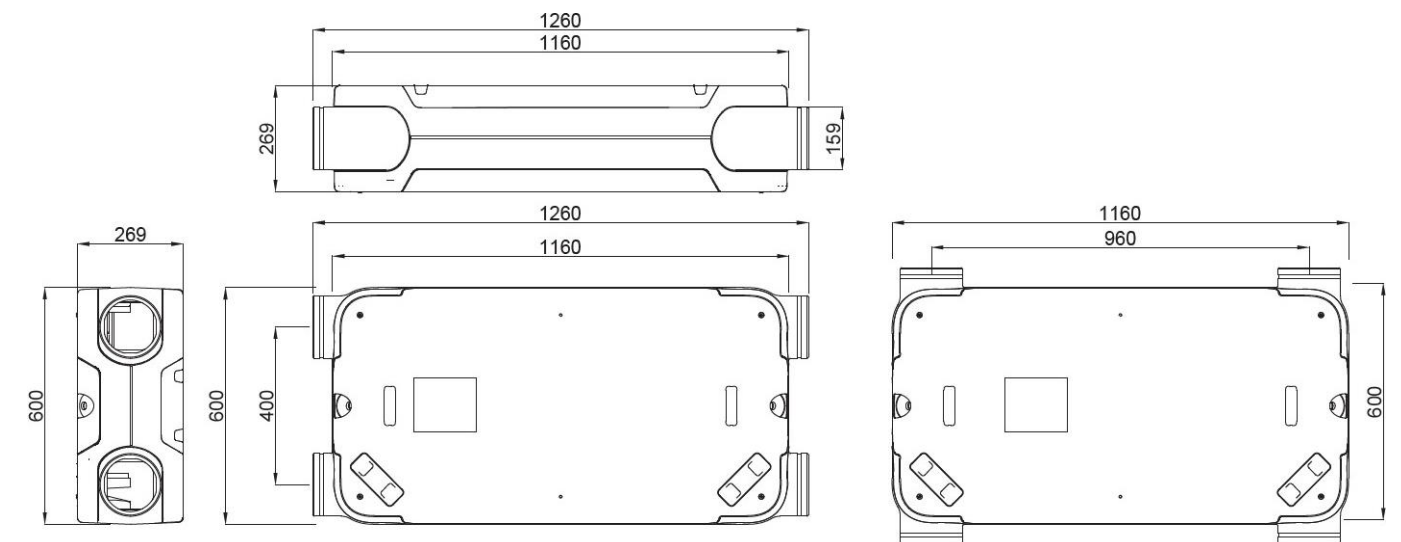

Wiring

Electrical connections should be carried out in accordance to [IEE regulations](#) by a qualified electrician. The unit is supplied with a flying lead for connection to the mains supply.

Two speed control via light switch
Connector box for mains voltage cabling (Not Supplied)

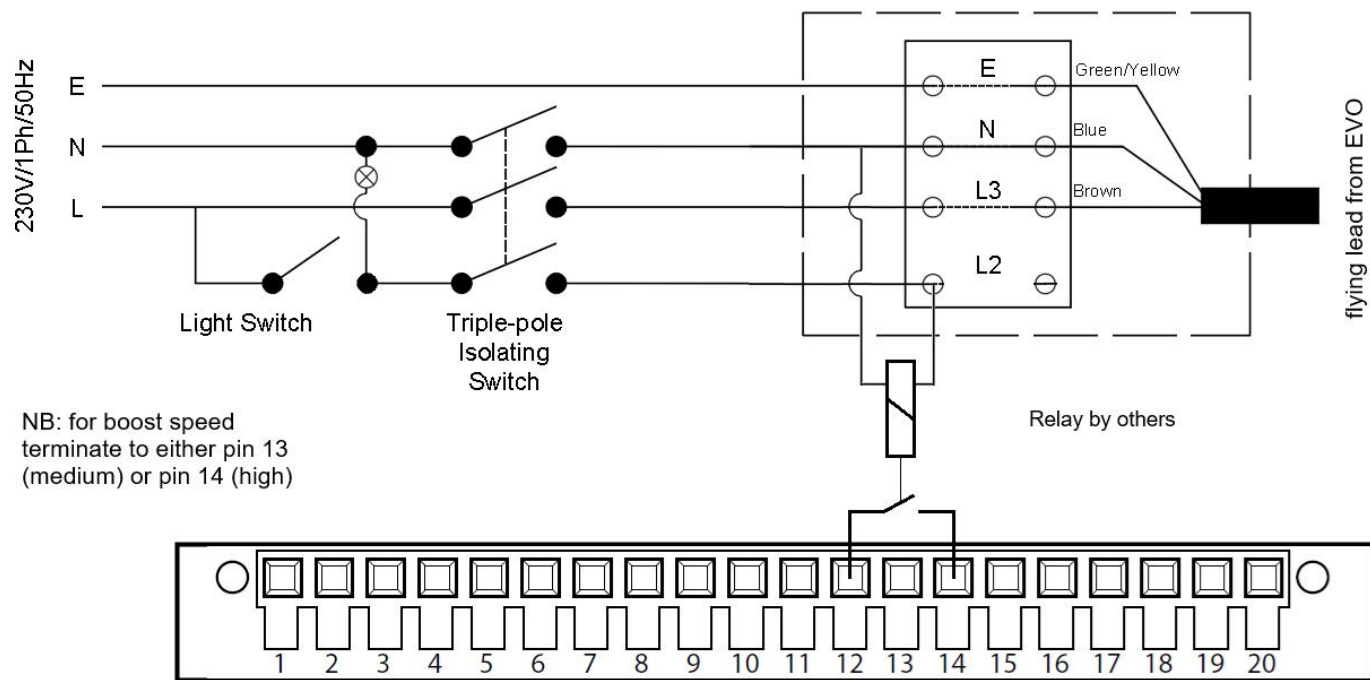

NB: for boost speed terminate to either pin 13 (medium) or pin 14 (high)

Integral control circuit board on EVO

Four speed control via EVO Sense controller

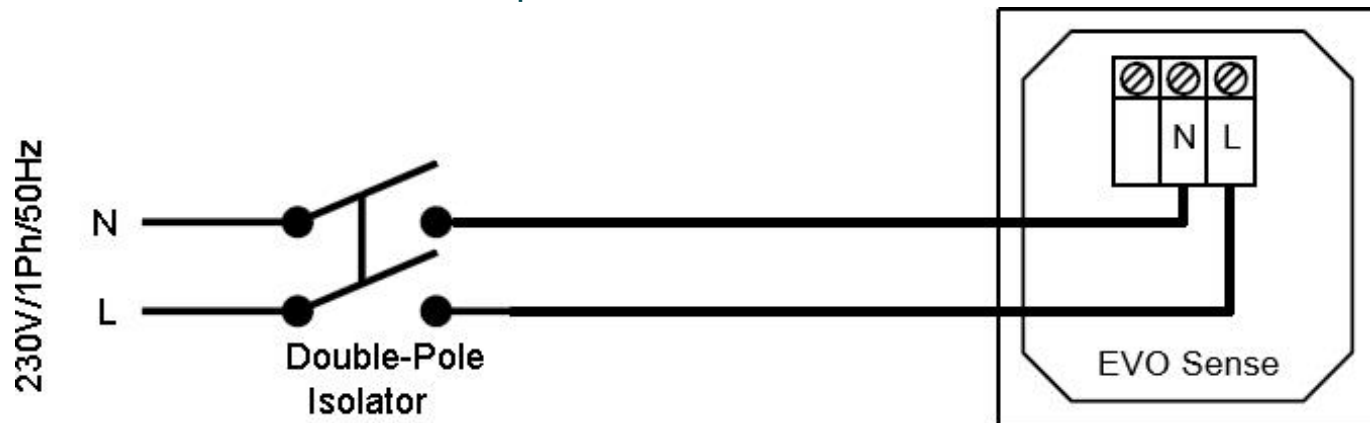

Controls

EVO Switch

Product code: 471 100 017

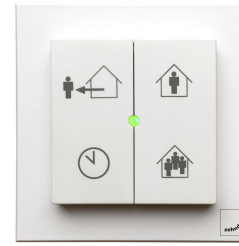

The Zehnder EVO Switch is a wireless multi position switch designed to enable the user to manually select the desired flow rate or overrun timer duration.

Key Benefits

- Wireless controller
- 3 separate ventilation flow rate options to select in 1 controller
- 3 temporary high speed activation settings (30 / 60 / 90 minutes)
- Service and Maintenance alert and filter reset

Technical Specification

Mounting options	Surface
Supply voltage	Powered by a coin cell lithium battery (type: CR 2032)
IP rating	IP30
RAL colour	9010
Maximum number per unit	99
Communication with the Zehnder EVO unit	Wireless, via two-way RF - 868 MHz RF protocol

Dimensions (surface mounted)

Height	84 mm
Width	84 mm
Depth	15 mm

EVO Sense

Product code: 471 100 018

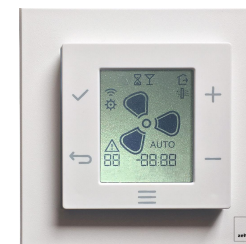

The Zehnder EVO Sense is a four position switch designed to enable the user to manually select the desired ventilation systems flow rate and provide system notifications

Key Benefits

- 4 separate ventilation flow rate options to select in 1 controller
- 7 day flow rate programmer
- Summer bypass indicator
- Service and Maintenance alert
- Clock function
- User menu access
- Installer menu access

Technical Specification

Mounting options	Surface / Recessed
Supply voltage	Mains power - 230 V / single-phase / 50Hz
IP rating	IP44
RAL colour	9010
Maximum number per unit	1
Communication with the Zehnder EVO unit	Wireless, via two-way RF - 868 MHz RF protocol

Dimensions (recessed)

Height	84 mm
Width	84 mm
Depth	12 mm

Dimensions (surface mounted)

Height	84 mm
Width	84 mm
Depth	53 mm

EVO CO2 sensor

Product code: 471 100 022



The Zehnder EVO CO2 wireless sensor and combined three position switch is designed to enable the user to manually select the desired ventilation systems flow rate based on the visual air quality indicator, or automatically adjust the unit relevant to the CO2 level for on demand control.

Key Benefits

- Green, yellow and red visual air quality indication light
- 3 separate ventilation flow rate options to select in 1 controller
- CO2 measuring range 400-2000 ppm
- Two modes available, COMFORT to adjust based on the ppm and ECO to increase the target value by 250 ppm

Technical Specification

Mounting options	Surface
Supply voltage	Mains power - 230 V / single-phase / 50Hz
IP rating	IP30
RAL colour	9010
Maximum number per unit	99
Communication with the Zehnder EVO unit	Wireless, via two-way RF - 868 MHz RF protocol
Accuracy	± 10% ppm @ 22 °C
Stabilisation period after start-up	40 ppm + 2% of reading at 20 °C at 2 minutes

Dimensions (surface mounted)

Height	100 mm
Width	100 mm
Depth	25 mm

EVO Humidity sensor

Product code: 471 100 023



The Zehnder EVO Humidity wireless sensor and combined three position switch is designed to enable the user to manually select the desired ventilation systems flow rate, or automatically adjust the unit relevant to the humidity level for on demand control.

Key Benefits

- 3 separate ventilation flow rate options to select in 1 controller
- Humidity measuring range 0-100% RH
- Two modes available, Manual speed selection or AUTO for demand control

Technical Specification

Mounting options	Surface
Supply voltage	Powered by 2 x AA batteries
IP rating	IP30
RAL colour	9010
Maximum number per unit	99
Communication with the Zehnder EVO unit	Wireless, via two-way RF - 868 MHz RF protocol
Accuracy	0-10% and 90-100%: ± 7% 11-89%: ± 3%

Dimensions (surface mounted)

Height	100 mm
Width	100 mm
Depth	25 mm

EVO Connect ModBus

Product code: 471 100 020



The Zehnder EVO Connect ModBus allows connection of the EVO units or sensors to be connected to a BMS system. The connection to the EVO device is wireless via RF and wired to the BMS.

Key Benefits

- Select the various fan speeds in manual mode and/or set timing programs using the ModBus building automation systems
- View any system errors using the ModBus building management system
- Wireless communication with Zehnder EVO ventilation unit and any sensors (humidity and/or CO2) and RS485 communication with building management system
- Allows programming of the unit's parameters during start-up and control of ventilation speeds and settings during normal operation

Technical Specification

Mounting options	Surface
Supply voltage	5 - 24 VAC /DC (tolerance 5 V DC - 0%; 24 V AC + 20%)
IP rating	IP20
Recommended cable	1 Pairs, 3 Cores, 0.36 mm ² , Screened, 22 AWG. (up to 50 metres)
RAL colour	9003
Maximum number per unit	1
Communication with the Zehnder EVO unit	Wireless, via two-way RF - 868 MHz RF protocol
Connectors	RS485
Communication protocols	Modbus RTU

Dimensions (surface mounted)

Height	90 mm
Width	92 mm
Depth	31 mm

Wiring



EVO Connect ModBus to KNX

Product code: 471 100 024



The Zehnder EVO Connect ModBus to KNX, together with the EVO Connect ModBus (sold separately), allows connection of the EVO units or sensors to be connected to a KNX system. The connection to the EVO device is wireless via RF and wired to the EVO Connect ModBus and BMS.

Key Benefits

- Select the various fan speeds in manual mode and/or set timing programs using the ModBus building automation systems
- View any system errors using the ModBus building management system
- Wireless communication with Zehnder EVO ventilation unit and any sensors (humidity and/or CO₂) and RS485 communication with building management system
- Allows programming of the unit's parameters during start-up and control of ventilation speeds and settings during normal operation

Technical Specification

Mounting options	Surface
Supply voltage	8-24 V AC / 12-35 V DC
IP rating	IP20
Recommended cable	J-Y(St)Y 2 x 2 x 0.8mm ²
Zehnder KNX library available at	https://www.zehnder.co.uk
Maximum number per unit	1
Connectors	Two way KNX RS485

Dimensions (surface mounted)

Height	95 mm
Width	71 mm
Depth	60 mm

Wiring



For use with

Our range of ComfoAir MVHR units can be used in conjunction with ComfoWell. The modular ComfoWell manifold can be combined with multiple circular connections for rigid round or semi-rigid connections. Along with filter boxes and attenuated manifold options, the ComfoWell is the perfect bespoke air distribution system for our ComfoAir MVHR units.

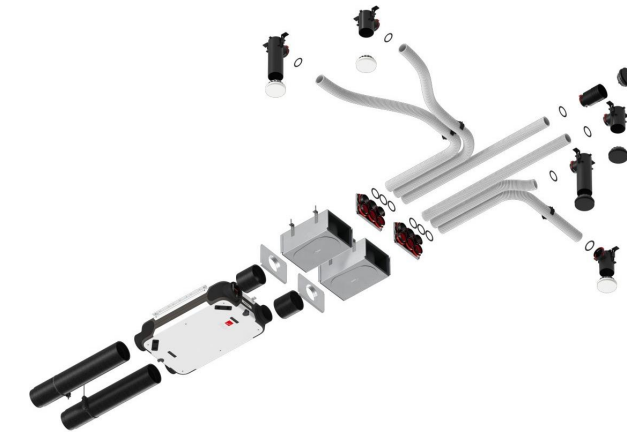

TO VIEW OUR COMFOWELL FOR EVO INFORMATION

[CLICK HERE](#)

BIM/CAD Components

If you would like to download the BIM / CAD files for this or any other of our products then please visit our BIM library.

TO VISIT OUR BIM/CAD LIBRARY

[CLICK HERE](#)

Installation Instructions

If you would like to download the installation files for this or any other of our products then please visit our download page by clicking the link below.

TO VISIT OUR DOWNLOAD PAGE

[CLICK HERE](#)

Our Informational Videos

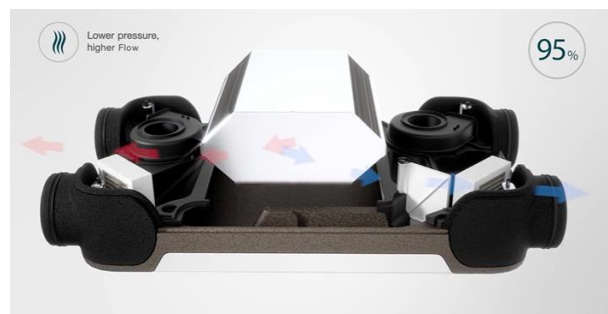

What our video on the EVO range of units.

TO WATCH OUR VIDEO

CLICK HERE



Watch our video on how to clean the Zehnder ComfoTube ductwork.

TO WATCH OUR VIDEO

CLICK HERE

Consultant Specification

Specification

The unit shall consist of a body manufactured in powder coated sheet steel. The unit shall be fully insulated using high quality EPP to maintain excellent thermal characteristics and prevent shrinkage over time. It shall have EC motors with fully-closed bearings. The fans impellers should be low pressure centrifugal type with forward curved blades within metal scroll housing and constant flow technology to ensure balanced airflow. The heat exchanger shall be a multi-plate, counter flow design constructed from aluminium and shall retain up to 89% of the temperature differential of outgoing air.

The unit shall contain filters which have been tested to a minimum of **ISO Coarse** (G4) standard with the option to upgrade to **ISO ePM1** (F7). The filters shall be pleated to reduce the pressure drop and required cleaning time. The unit shall have rotatable 160 mm duct connections, and be suitable for vertical wall or horizontal ceiling mounting with the ability to allow factory or mirror hand configuration. Integrated preheater option shall be available to regulate its output to enable balanced ventilation with external air temperatures -10°C.

The unit shall have 100% full summer by-pass and provide filtered supply air 365 days of the year, even under bypass conditions. The unit shall contain a temperature sensor for each air stream to ensure correct and logical operation of the bypass damper by evaluating differential as well as absolute temperature to maximise the opportunity for free cooling. The unit shall control air flow to react to prolonged, sustained increased pressure drops to best achieve the commissioned flow rate even when filter degradation occurs.

The unit shall be constructed to have a removable cover to allow full maintenance access. The removable cover shall enable access to the supply/extract fan, heat exchanger and access to electrical connections. The motors shall be suitable for removal without the requirement for the unit to be removed from situ and be available as spare parts for a minimum of 10 years even after ceasing manufacture of the unit.

The unit shall conform to LVD and EMC standards and be CE Marked in addition to having an EU compliant energy rating label (SEC) with a minimum grade of A. The unit shall be manufactured by Zehnder.

Operation

The supply and extract unit shall be an EVO manufactured by Zehnder and shall be suitable for vertical wall or horizontal ceiling mounting in accordance with the specification.

The fresh filtered air from outside shall be supplied to each of the habitable rooms and pre-heated by the warm extract air from the wet areas, such as kitchen or bathroom, via the plastic counter flow heat exchanger. The unit shall vary its speed of the EC motors automatically when it receives a signal from one of the inbuilt sensors or via external switches.

The unit shall have the ability to adjust and commission the supply and extract motors independently via the separate controller. The motors shall both automatically adjust independently to the system pressure to achieve the input flow rate.

Controls

All EVO units shall contain the following functions within the unit pre-wired and factory fitted by the manufacturer:

- RF enabled as standard for use with remote controllers and sensors
- 100% variable supply and extract motor control
- 4 Variable speed flow rate set points
- Automatic filtered summer bypass
- Heat exchanger frost protection
- Fire stop contact
- Tool free filter access
- Switched live input
- Automatic passive boost for night time cooling

All EVO units shall contain the following options when combined with relevant ancillaries:

- BMS compatibility via Modbus protocol option (EVO Connect ModBus)
- BMS compatibility via KNX protocol option (EVO Connect ModBus + EVO Connect KNX)
- Pre-heater frost protection option
- Wireless input for 4 speed manual/auto controller with filter alert, required for commissioning (EVO Sense)
- Wireless input for single or multiple 3 speed manual controller with filter alert and temporary boost overrun (EVO Switch)
- Wireless input for single or multiple CO2 sensors with combined 3 speed manual controller (EVO CO2 sensor)
- Wireless input for single or multiple Humidity sensors with combined 3 speed manual controller (EVO Humidity sensor)

Zehnder Group UK Limited · Concept House · Watchmoor Point · Camberley · Surrey · GU15 3AD
T +44 1276 408404 · info@zehnder.co.uk · www.zehnder.co.uk