

Fair



**AT SCHOOL
THE VMC/MEV
BECOME SMART
AND IT CONTROLS
ALSO AIR QUALITY**



VMC/MEV IN CLASSROOMS

Mechanical ventilation
with heat recovery and
air quality control



Air renewal in rooms is one of the countermeasures recommended by the ISS (Italian National Institute of Health) to reduce the likelihood of contagion from COVID-19.

In fact, a recent report reiterates that all indoor spaces must be well-ventilated with a flow of fresh air. In particular, the ventilation of classrooms and school spaces is essential to mitigating dangers caused by airborne virus transmission.



IS OPENING THE WINDOWS ENOUGH?

Opening windows is not always enough to really improve the quality of the air you breathe. In a normal-sized classroom, to completely renew the air, the windows need to stay open for 20 minutes every 40 minutes. A difficult solution to implement, especially in the winter.

How should we prepare for the new school year? This is where controlled mechanical ventilation comes into play.

An article on orizzontescuola.it says, word for word: "For the first time it has been documented that doubling the incoming air flow through controlled mechanical ventilation (MEV) systems, calculated in cubic meters per hour inside a closed room, reduces the concentration of infected particles by 99.6%."

For this reason, ventilation systems are useful for improving the conditions and comfort of the room that we spend our days in.

VMC/dMEV: the ready-for-use solution ideal for school classrooms

Fantini Cosmi, with the Aspira brand, offers a wide and comprehensive range of MEV solutions to fulfil all needs, from small rooms to large areas. ASPIRCOMFORT CLASS and ASPIRCOMFORT PRO X are among the fastest solutions to **fight indoor pollution: ventilation units complete with recuperator particularly suitable for single rooms where it may not be possible to create ducted systems.**

ASPIRCOMFORT CLASS

Thanks to its construction features and components, **Aspircomfort Class 620H** is able to reach recovery efficiency of more than 90% and a maximum flow rate of 620 m³/h. Horizontal installation means it can be ceiling-mounted, without affecting the aesthetics of the premises. Silent and compact Aspircomfort Class 620H is specially designed for school classrooms and wherever a certain air renewal level is required with great acoustic comfort performance. The product can be controlled from the ultra-flat LCD touch screen remote panel **CH193VMC**, which allows advanced control of the ventilation system and also controls the air quality.

ASPIRCOMFORT PRO X SERIES

The Aspircomfort Pro X decentralised ventilation unit is equipped with a heat pump with cooling circuit and active thermodynamic recovery that allows it to also guarantee the air conditioning of the incoming air and thus also satisfy the heating and cooling needs as well as the air renewal of the rooms it serves. Aspircomfort Pro X is available in two models: **Aspircomfort Pro X 460H** for horizontal installation, and **Aspircomfort Pro X 380V** for vertical installation.

All Aspircomfort Class and ASPIRCOMFORT PRO X models come complete with every component and are ready for use: in fact, they do not require additional air distribution systems (pipes and fittings), neither for input nor output, and are installed directly on the perimeter wall by drilling two simple holes on said wall.

Plus, the units feature a practical power supply cable with **Shuko plug** for a quick connection to the electrical power line.

ASPIRCOMFORT CLASS
Decentralised ventilation only unit
with very high efficiency dual flow heat recovery
unit

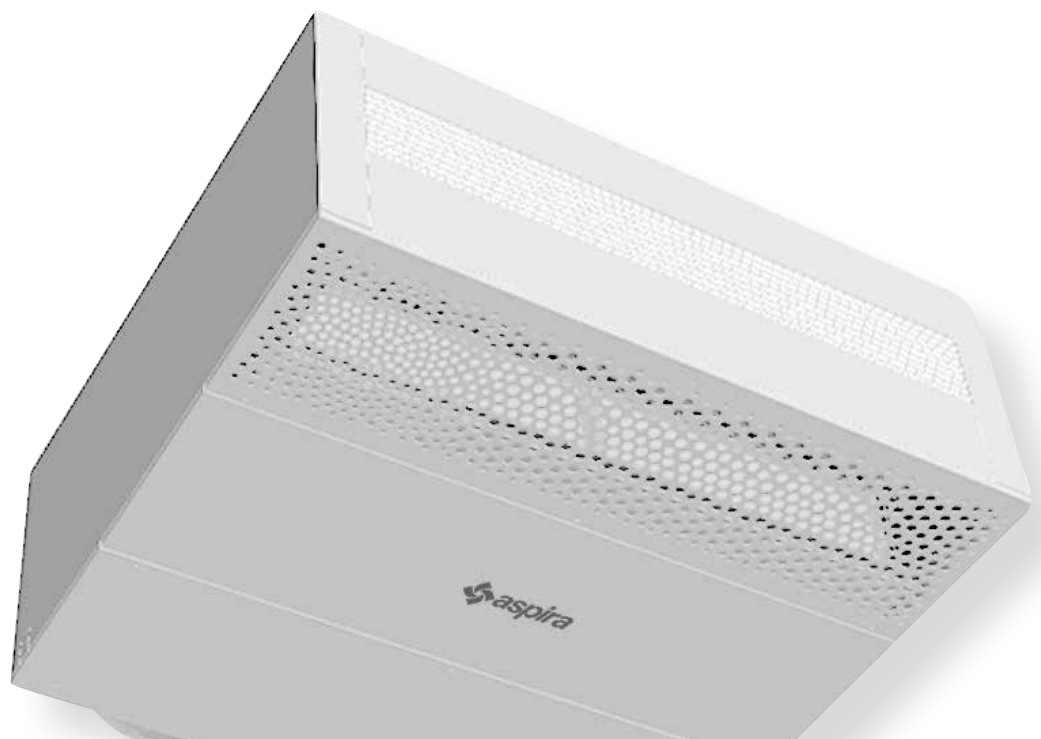

ALSO CONTROLS AIR QUALITY

Aspircomfort Class and Aspircomfort Pro X ventilation units also control the air quality to offer **well-being and comfort** in the classrooms and school spaces.

INSTALLATION WITH FULL PEACE OF MIND

Easy and quick to install, the Aspircomfort Class and Aspircomfort Pro X VMC/dMEV units do not require additional air distribution systems and are installed directly on the external wall with only 2 holes on said wall, and a Shuko plug.

ULTRA-SILENT OPERATION

The low noise levels, with only 34 dB/A on average at 4 meters make the Aspircomfort Class air renewal units particularly suitable for installation in environments such as **school classrooms, libraries and other study areas**.

COMFORT IN EVERY SEASON

The Aspircomfort Pro X ventilation units are also equipped with a heat pump to ensure, in addition to **air renewal and thermodynamic heat recovery**, the **air conditioning of the incoming air**, able to satisfy the heating and cooling needs of the rooms.



CH193VMC
Centralised control unit for VMC/MEV systems

DUAL FLOW AIR RECIRCULATION

The Aspircomfort ventilation units are controlled by a Brushless motor with directly coupled electronic motor and modulating control that makes it possible to obtain maximum comfort with lower consumption and more silent operation. The fans are mainly controlled by CO₂, VOC, temperature and humidity sensors placed inside the unit which regulate its automatic operation.

The air is also constantly filtered through ePM1 80% filters that are easily removable for periodic cleaning.

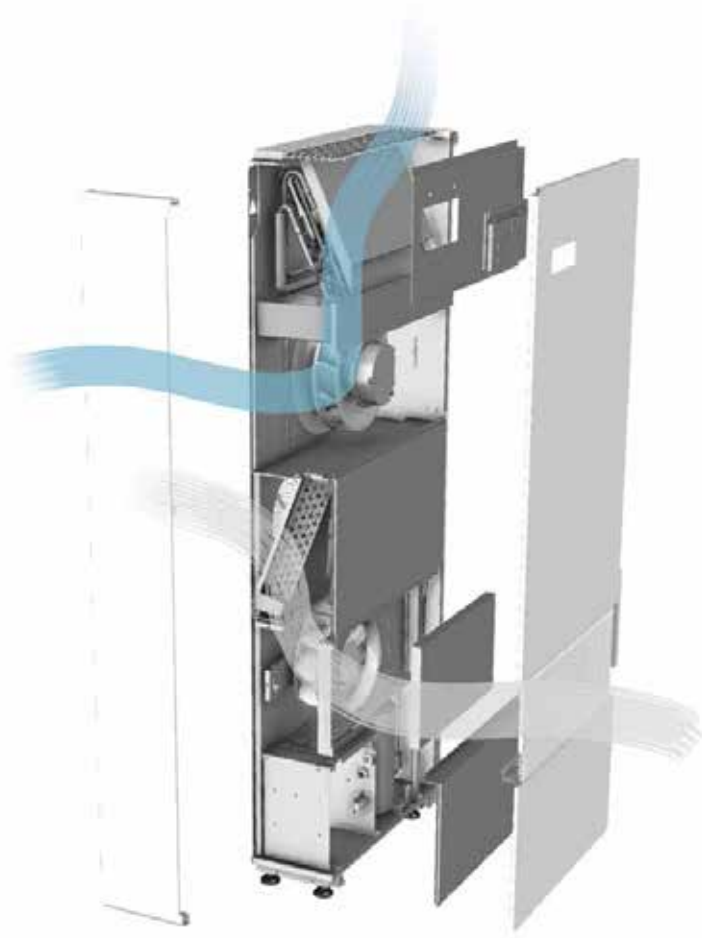

INDOOR AIR QUALITY SENSORS

In Aspira ventilation systems, the temperature, the relative humidity (RH%), the concentration of carbon dioxide (CO₂) and volatile organic compounds (VOC) is constantly monitored by the on-board sensors of the device which, based on the values detected, adjust the fresh air flow rate according to real needs.

VERY HIGH RECOVERY EFFICIENCY > 90%

During operation, the air renewal unit uses heat recovery with an efficiency of over 90% to transfer the heat from the extracted air to the air supplied into the home. The complete and safe separation between the extracted indoor air and the supplied outdoor air gives the units greater thermal efficiency and better filtration of the supplied air.

The continuous use of the unit helps prevent dampness, the formation of mould on the walls and maintains a constantly low level of pollutants.

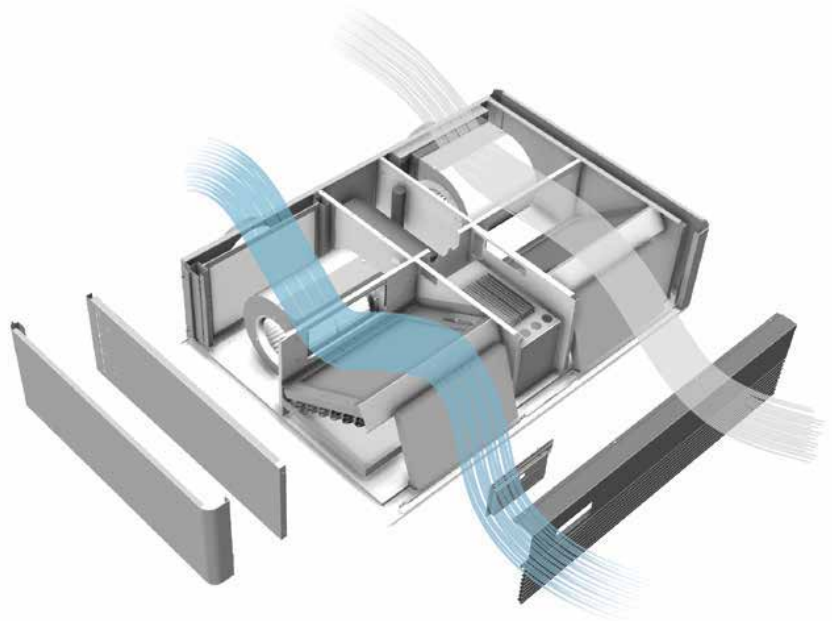

ASPIRCOMFORT PRO X 460H
Decentralised ventilation unit
with horizontal installation.

Other page
ASPIRCOMFORT PRO X 380V
Decentralised ventilation unit with vertical
installation



ALSO IN THE SUMMER: FRESH AIR

In summer, ASPIRCOMFORT CLASS and ASPIRCOMFORT PRO X eliminate excess humidity and recover "cold" from the AC air drawn from the room and transfer it to the air going in.

Thanks to the **Free Cooling** function - when the outdoor temperature is lower than the indoor one - ASPIRCOMFORT CLASS helps guarantee greater thermal comfort, with a sure advantage in terms of both comfort and energy efficiency. The ASPIRCOMFORT PRO X ventilation units are also equipped with a heat pump to ensure, in addition to air renewal and heat recovery, the air conditioning of the incoming air, able to also satisfy the heating and cooling needs of the rooms.

ASPIRCOMFORT CLASS 620H

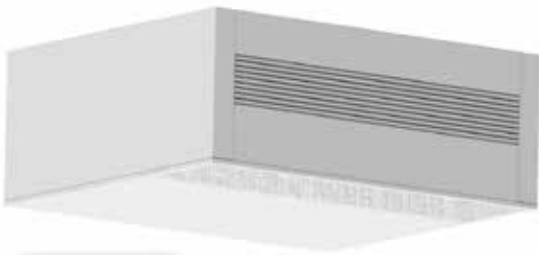

Decentralised ventilation unit with heat recovery for horizontal installation.

Ventilation unit with decentralised heat recovery particularly suitable for single rooms where it is not possible to create ducted systems and suitable for commercial applications, offices and classrooms.

Horizontal installation means it can be installed also on a false ceiling, without affecting the aesthetics of the premises.

- For commercial applications, schools, offices
- Very high recovery efficiency >90%
- Low noise levels
- Horizontal installation
- Unit complete and ready for use
- Adjustment from CH193VMC remote panel with air quality control
- Power supply cable with Shuko plug

Thanks to its construction features and components, Aspircomfort Class 620H is able to reach recovery efficiency of more than 90% and a maximum flow rate of 620 m³/h. With this solution, in the winter and summer seasons there is considerable energy recovery of the renewal air that enters the room. For example, thanks to the **Free Cooling** function, in summer the outdoor temperature is lower than the indoor one – the function helps to ensure greater thermal comfort while recovering efficiency.

The product can be controlled from remote panel CH193VMC, which allows advanced control of speed and operating modes. Equipped with temperature, relative humidity sensor it also controls the air quality, for automatic control of MEV speed. The CH193VMC control panel features an ultra-flat negative LCD touch screen display with white backlighting.

Aspircomfort Class comes complete with every component and is ready for use: in fact, it does not require additional air distribution systems (pipes and fittings), neither for input nor output, and is installed directly on the external wall.

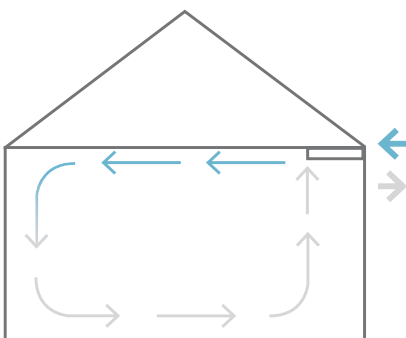

HOMOLOGATION AND STANDARDS

The CE marking (applied on each machine) certifies compliance with the following Community standards:

- Low Voltage Directive 2014/35/EC
- Electromagnetic Compatibility Directive 2014/30/EC
- Ecodesign 2009/125/EC



TECHNICAL FEATURES

TOTAL FLOW RATE	m ³ /h [@100 Pa]	620
RENEWED AIR FLOW RATE	m ³ /h [@100 Pa]	620
SOUND PRESSURE LEVEL [1m]	dB(A)	50.5
SOUND PRESSURE LEVEL [3m]	dB(A)	41.0
SOUND PRESSURE LEVEL [4m]	dB(A)	38.5
PROTECTION RATING	IP	X0
Room relative humidity display scale		0 - 99%, increase 1%

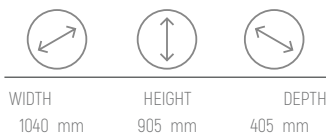
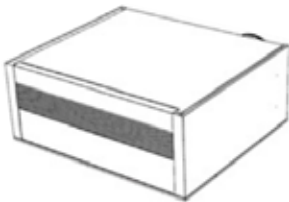

DIMENSIONS [mm]

Width L	mm	1040
Depth P	mm	905
Height H	mm	405
Diameter DN	Ø mm	250
Weight	Kg	71
Condensation	Ø mm	20

GENERAL SPECIFICATIONS

- Self-supporting sheet metal frame with polyethylene insulated interior.
- Very high efficiency polypropylene cross flow counter current exchanger. Low freezing temperatures and operation down to -25°.
- Brushless forward curved centrifugal fans with electronic motor and modulating control. Very high efficiency and low noise levels.
- ePM1 70% filters with low head loss. Easily removable by removing the lower outer panels.
- Free cooling inside the unit with generous air flow and damper with motorised actuator.

- Control of 4 fan speeds, antifreeze, automatic bypass, temperature probes, post-heating coils and automatic dirty filter signal.
- CH193VMC control panel mandatory for unit operation

ACCESSORIES SUPPLIED

- No. 2 connections Ø 250 mm
- Insulated mattress
- No. 2 fixed grids Ø 250 mm for external walls
- Pre-wired 10 m cable for connecting remote panel CH193VMC

ASPIRCOMFORT PRO X 460H



- For commercial applications, schools, offices
- Very high recovery efficiency >90%
- Heat pump
- Horizontal installation
- Unit complete and ready for use
- UV-C lamp (optional)
- Power supply cable with Shuko plug

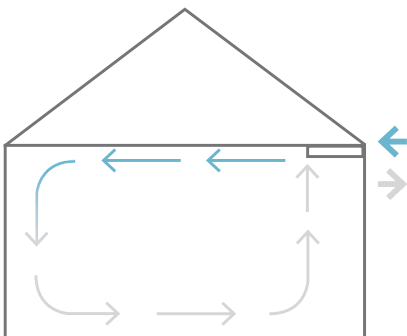

Decentralised ventilation unit with horizontal installation, equipped with heat pump and thermodynamic recovery.

Aspircomfort PRO X is a unit designed for the renewal and sanitisation of the air of medium-small rooms. This solution is capable of independently integrating the ventilation requirements and integrating the cooling thermal requirements of the served rooms.

The high fresh air flow rate allows the application in situations such as residential buildings, schools, surgeries, offices and all contexts where air exchange is required. The unit is designed to be equipped with the UV-C lamp that provide a germicidal action on the air coming in from outside. The lamp is activated **automatically based on the room air quality**. For example, this feature makes Aspircomfort PRO X particularly suitable also for **medical and dental offices as well as school classrooms** and any other facility with high traffic where you want to keep the air sanitised.

The **thermodynamic recovery** allows for integration according to the environmental climatic conditions, helping the air conditioning system fulfil the demand with a temperature close to or better than the room temperature, thus ensuring a higher perceived comfort.

The panel with graphic interface and remote control included allows fan management with air quality probe, temperature display and setpoint, timed dirty filter management.

The unit is composed of a monoblock which includes every component for correct operation and is ready for use. Installation is therefore simplified and economical as it does not require additional air distribution systems (pipes and fittings), neither for input nor output, and is installed directly on the external wall by two holes with a 160 mm diameter.

HOMOLOGATION AND STANDARDS

The CE marking (applied on each machine) certifies compliance with the following Community standards:

- Low Voltage Directive 2014/35/EC
- Electromagnetic Compatibility Directive 2014/30/EC

CE EAC

TECHNICAL FEATURES

TOTAL FLOW RATE	m ³ /h [@100 Pa]	460
RENEWED AIR FLOW RATE	m ³ /h [@100 Pa]	460
SPI	W/(m ³ /h)	0.26
SOUND PRESSURE LEVEL [1m]	dB(A)	50
SOUND PRESSURE LEVEL [3m]	dB(A)	43
PROTECTION RATING	IP	X0

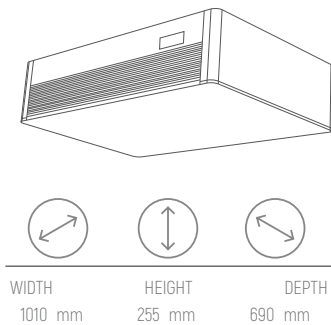

DIMENSIONS [mm]

Width L	mm	1010
Depth P	mm	690
Height H	mm	255
DN Outdoor air/ exhaust	mm	162
Condensation	∅ mm	20
Weight	kg	74

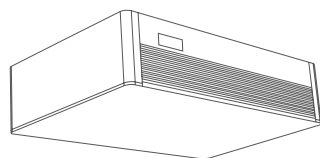

Front view

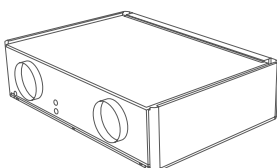

Rear view

GENERAL SPECIFICATIONS

- Centrifugal fans with constant flow, with directly coupled brushless electronic motor and modulating control.
- The inverter refrigeration unit allows active recovery of energy from the exhaust air. The thermodynamic recovery allows, thanks to its cooling circuit, to supply energy to the environment in a higher quantity than that taken away by the ventilation for 90% of the unit's operation.
- EPM1 filter placed after the coil to completely filter out any impurities in the supplied air. On the outdoor air there is a Coarse pre-filter that protects the cleanliness of the unit.
- Self-supporting sheet metal frame. Self-supporting sheet metal structure, externally painted (in the visible versions), with polyethylene and EPDM thermal and acoustic insulation in between.
- Cooling circuit made of brazed copper complete with high-efficiency BLDC compressor, filter dryer, finned coils, electronic expansion valve, reversing valve and safety devices.
- Electric panel on-board the unit with microprocessor and dedicated regulation.
- Fan management with air quality probe, temperature display and setpoint, timed dirty filter management. Panel with graphic interface and remote control included.
- The unit is designed to be equipped with the UV-C lamp that makes it possible to perform a germicide action on the air supplied from outdoors, through the effect of the UV-C. The lamp is activated automatically based on the room air quality.

ASPIRCOMFORT PRO X 380V



Decentralised ventilation unit with vertical installation, equipped with heat pump and thermodynamic recovery.

Aspircomfort PRO X is a unit designed for the renewal and sanitisation of the air of medium-small rooms. This solution is capable of independently integrating the ventilation requirements and integrating the cooling thermal requirements of the served rooms.

The high fresh air flow rate allows the application in situations such as residential buildings, schools, surgeries, offices and all contexts where air exchange is required. The unit is designed to be equipped with the UV-C lamp that provide a germicidal action on the air coming in from outside. The lamp is activated automatically based on the room air quality. For example, this feature makes Aspircomfort PRO X particularly suitable also for **medical and dental offices as well as school classrooms** and any other facility with high traffic where you want to keep the air sanitised.

The thermodynamic recovery allows for integration according to the environmental climatic conditions, helping the air conditioning system fulfil the demand with a temperature close to or better than the room temperature, thus ensuring a higher perceived comfort.

The panel with graphic interface and remote control included allows fan management with air quality probe, temperature display and setpoint, timed dirty filter management.

The unit is composed of a monoblock which includes every component for correct operation and is ready for use. Installation is therefore simplified and economical as it does not require additional air distribution systems (pipes and fittings), neither for input nor output, and is installed directly on the external wall by two holes with a 160 mm diameter.

- For commercial applications, schools, offices
- Very high recovery efficiency >90%
- Heat pump
- Vertical installation
- Unit complete and ready for use
- UV-C lamp (optional)
- Power supply cable with Shuko plug

HOMOLOGATION AND STANDARDS

The CE marking (applied on each machine) certifies compliance with the following Community standards:

- Low Voltage Directive 2014/35/EC
- Electromagnetic Compatibility Directive 2014/30/EC

CE EAC

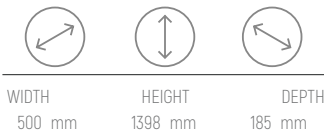
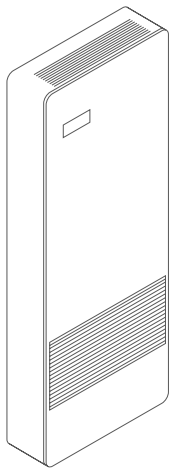

TECHNICAL FEATURES

TOTAL FLOW RATE	m ³ /h [@100 Pa]	380
RENEWED AIR FLOW RATE	m ³ /h [@100 Pa]	380
SPI	W/(m ³ /h)	0.245
SOUND PRESSURE LEVEL [1m]	dB(A)	48
SOUND PRESSURE LEVEL [3m]	dB(A)	41
PROTECTION RATING	IP	X0

DIMENSIONS [mm]

Width L	mm	500
Depth P	mm	185
Height H	mm	1398
DN Outdoor air/ exhaust	mm	162
Condensation	∅ mm	20
Weight	kg	53

GENERAL SPECIFICATIONS

- Brushless plug-fans with directly coupled electronic motor and modulating control.
- The inverter refrigeration unit allows active recovery of energy from the exhaust air. The thermodynamic recovery allows, thanks to its cooling circuit, to supply energy to the environment in a higher quantity than that taken away by the ventilation for 90% of the unit's operation.
- EPM1 filter placed after the coil to completely filter out any impurities in the supplied air. On the outdoor air there is a Coarse pre-filter that protects the cleanliness of the unit
- Self-supporting sheet metal frame. Self-supporting sheet metal structure, externally painted (in the visible versions), with polyethylene and EPDM thermal and acoustic insulation in between.
- Cooling circuit made of brazed copper complete with high-efficiency BLDC compressor, filter dryer, finned coils, electronic expansion valve, reversing valve and safety devices.
- Electric panel on-board the unit with microprocessor and dedicated regulation.
- Fan management with air quality probe, temperature display and setpoint, timed dirty filter management. Panel with graphic interface and remote control included.
- The unit is designed to be equipped with the UV-C lamp that makes it possible to perform a germicide action on the air supplied from outdoors, through the effect of the UVC. The lamp is activated automatically based on the room air quality.

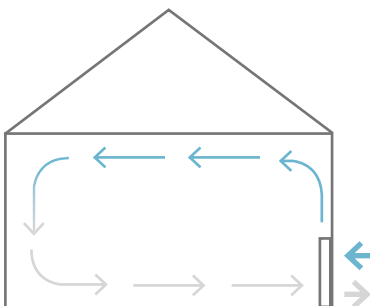





The features referring to the equipment in this catalogue are not binding. The company Fantini Cosmi S.p.A. reserves the right to make changes without prior or public notice for technological improvement, regulatory evolution and commercial matters, without prejudice to the main functional features of the models.



FANTINI COSMI SPA Via dell'Osio, 6 - 20049 Caleppio di Settala MI, Italy
Tel. +39 02 956821 | Fax +39 02 95307006 | info@fantinicosmi.it

EXPORT DEPARTMENT
Ph +39 02 95682229 | Fax +39 02 95307006 | export@fantinicosmi.it

www.fantinicosmi.com

